



# TYPHOON INTAKE SYSTEMS

INTAKE SYSTEMS FOR VEHICLES LISTED ARE 50 STATE LEGAL. SEE KNFILTERS.COM FOR CARB STATUS ON EACH PART FOR A SPECIFIC VEHICLE.

## INSTALLATION INSTRUCTIONS

### 69-5313TS

### KIA

### 2014 Soul

### L4-2.0L

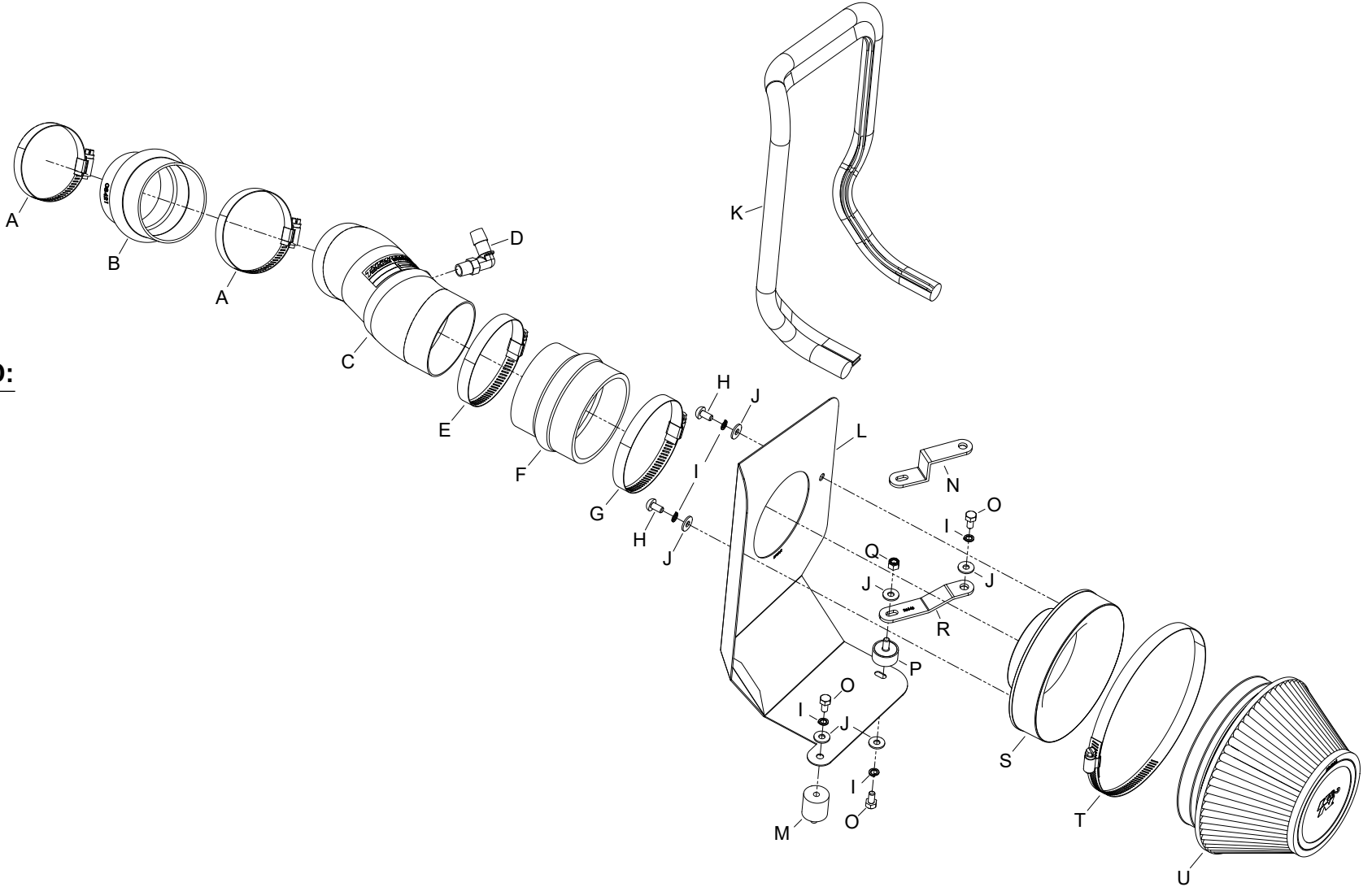

#### TOOLS NEEDED:

- flat blade screw driver
- ratchet
- long extension
- 10mm socket
- pliers

#### PARTS LIST:

Description	Qty.	Part #	Description	Qty.	Part #	Description	Qty.	Part #
A HOSE CLAMP #44 STAINLESS	2	08560	H BOLT; M6 X 1.00" 12MM, SS	2	07794	O BOLT; M6 X 1.00 X 12MM, SS	3	07727
B HOSE; 3" TO 2 3/4" X 3"L HUMP	1	08421	I WASHER; M6 SPLIT LOCK ZINC	5	1-3025	P STUD; RUBBER MNT, M/F, 1/2"L	1	070228
C INTAKE TUBE	1	27576	J WASHER; 6MM FLAT, SS	6	08269	Q NUT; 6MM NYLOCK, HEXHEAD	1	07512
D VENT; 90 DEG, 1/2" HOSE, 1/4"	1	08110FK	K EDGE TRIM ( 37")	1	102496	R BRACKET; 57-1521, "Z", TB/PC	1	26545
E HOSE CLAMP # 52	1	08610	L HEAT SHIELD	1	073161-1	S ADAPTER; UNIVERSAL, 6"	1	21512-1
F HOSE; HUMP 3.25/3.50 X 3.00"	1	5-576	M STUD; RUBBER MOUNT, M6	1	02033	T HOSE CLAMP # 104	1	08697
G HOSE CLAMP # 56	1	08620	N BRACKET; "Z", SML	1	020003	U AIR FILTER	1	RU-4600

If you need any assistance please call 1-800-858-3333 to speak with a representative in our Customer Service Center before returning the product.

**NOTE: FAILURE TO FOLLOW INSTALLATION INSTRUCTIONS AND NOT USING THE PROVIDED HARDWARE MAY DAMAGE THE INTAKE TUBE, THROTTLE BODY AND ENGINE.**

#### TO START:

1. Turn off the ignition and disconnect the negative battery cable.  
**NOTE: Disconnecting the negative battery cable erases pre-programmed electronic memories. Write down all memory settings before disconnecting the negative battery cable. Some radios will require an anti-theft code to be entered after the battery is reconnected. The anti-theft code is typically supplied with your owner's manual. In the event your vehicles anti-theft code cannot be recovered, contact an authorized dealership to obtain your vehicles anti-theft code.**

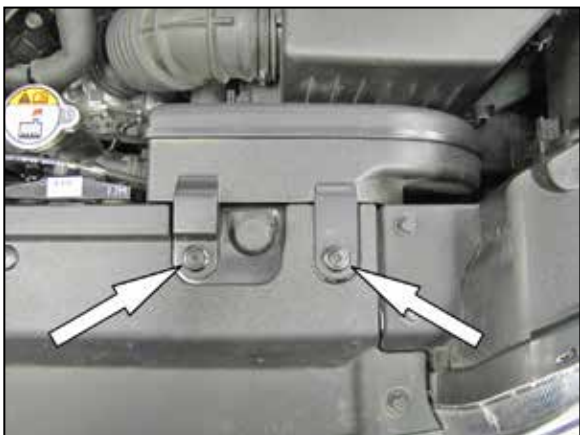

2. Loosen and remove the plastic screws securing the fresh air scoop.



3. Pull up and remove the fresh air scoop from the vehicle.



4. Release the spring clamp securing the crank case vent hose to the intake tube and then disconnect the crank case vent hose.



5. Loosen the hose clamp securing intake tube to the throttle body.



6. Remove the two bolts securing the air box.



7. Lift up and remove the air box and intake tube from the vehicle.

**NOTE: K&N® Engineering, Inc., recommends that customers do not discard factory air intake.**



8. Install the 1" male to female rubber mounted stud onto the frame rail as shown.



9. Install the filter adapter into the heat shield and secure with the provided hardware.

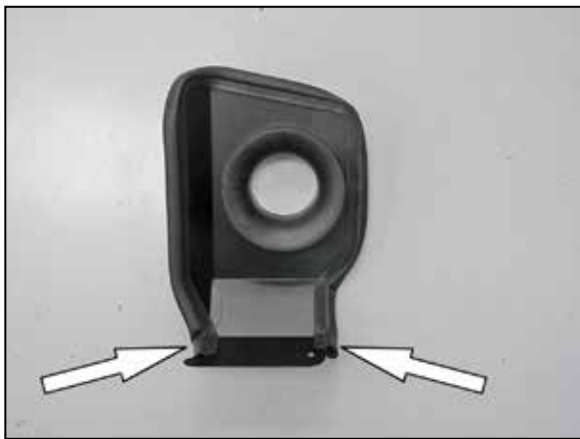

10. Install the provided edge trim around the heat shield as shown.

**NOTE: Some trimming of the edge trim will be necessary.**



11. On 2018 and earlier vehicles, install the 6mm male to male rubber mounted stud onto the heat shield as shown using the provided hardware.



12. On 2018 and earlier vehicles, Install the mounting bracket (26545) onto the rubber mounted as shown using the provided hardware.

On 2019 and later model vehicles, install the provided bracket #020003 short leg directly onto the heat shield using the provided hardware



13. Install the heat shield assembly onto the rubber mounted stud and align the mounting bracket with the mounting hole. Secure the heat shield with the provided hardware.



14. Install the provided hump hose (08421) onto the throttle body and secure with the provided hose clamp.



15. Install the provided hump hose (5-576) onto the filter adapter and secure with the provided hose clamp.



16. Install the 90° vent fitting into the K&N® intake tube as shown.

**NOTE: Plastic NPT fittings are easy to cross thread. Install the vent fitting "hand" tight, then turn it two complete turns with a wrench.**



17. Flex the heat shield assembly towards the driver's side fender and then install the K&N® intake tube into the coupling hoses. Adjust the tube and heat shield for best fit and then secure with the provided hose clamps.



18. Install the K&N® air filter onto the filter adapter and secure with the provided hose clamp.



19. Install the crank case vent hose onto the 90° fitting and secure with the factory spring clamp.



20. Reconnect the vehicle's negative battery cable. Double check to make sure everything is tight and properly positioned before starting the vehicle.

21. The C.A.R.B. exemption sticker, (attached), must be visible under the hood so that an emissions inspector can see it when the vehicle is required to be tested for emissions. California requires testing every two years, other states may vary.

22. It will be necessary for all K&N® high flow intake systems to be checked periodically for realignment, clearance and tightening of all connections. Failure to follow the above instructions or proper maintenance may void warranty.

#### ROAD TESTING:

1. Start the engine with the transmission in neutral or park, and the parking brake engaged. Listen for air leaks or odd noises. For air leaks secure hoses and connections. For odd noises, find cause and repair before proceeding. This kit will function identically to the factory system except for being louder and much more responsive.

2. Test drive the vehicle. Listen for odd noises or rattles and fix as necessary.

3. If road test is fine, you can now enjoy the added power and performance from your kit.

4. K&N Engineering, Inc., requires cleaning the intake system's air filter element every 100,000 miles. When used in dusty or off-road environments, our filters will require cleaning more often. We recommend that you visually inspect your filter once every 25,000 miles to determine if the screen is still visible. When the screen is no longer visible some place on the filter element, it is time to clean it. To clean and re-oil, purchase our filter Recharger® service kit, part number 99-5050 or 99-5000 and follow the easy instructions.

**INTAKE SYSTEMS FOR VEHICLES LISTED ARE 50 STATE LEGAL. SEE KNFILTERS.COM FOR CARB STATUS ON EACH PART FOR A SPECIFIC VEHICLE.**