



QUALITY... PLAIN & SIMPLE®

LED Boot Indicator Instructions

GM TH-350, TH-400, 700-R4, 4L60, Ford C-4/C-6, Ford AOD, Chrysler 727/518/904

LED Boot Indicator Installation Instructions

GM TH-350, TH-400, 700-R4, 4L60, Ford C-4/C-6, Ford AOD, Chrysler 727/518/904

Building American Quality... With A Lifetime Warranty!

10924 Murdock Dr. • Knoxville, TN 37932

TOLL FREE 1-877-469-7440 • (865) 966-2269 • FAX (865) 671-1999 • tech@lokar.com • www.lokar.com

General Installation Notes:

Please read instructions completely before beginning installation. If you have any questions please call.

Shift pattern lights only after kit is wired and indicator is engaged.

Before starting installation, set parking brake and scotch vehicle to avoid accidental movement of the vehicle. Disconnect battery cable before starting installation.

LED Boot Indicator Installation

Step 1: When installing aluminum bezel, route wiring harness away from sharp edges.

Step 2: Round Boot Ring inner diameter is 4". **DO NOT CUT FLOOR OPENING BIGGER THAN A ROUND 4" HOLE.**

Rectangular Boot Ring inner dimensions are 4" x 5 1/4". **DO NOT CUT FLOOR OPENING BIGGER THAN 4" x 5 1/4".**

Step 3: When drilling holes for screws, use #32 or 1/8" drill.

Step 4: Use appropriate transmission wiring diagram to wire LED Indicator to Decoder Box. (See diagrams)

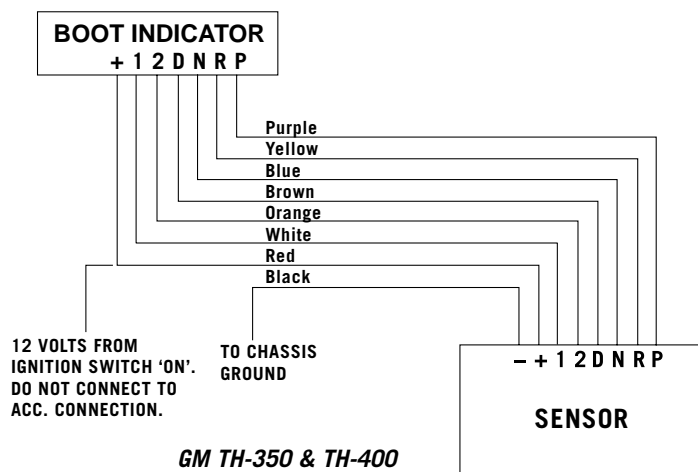

GM TH-350 & TH-400
Ford C-4/C-6
Ford AOD
Chrysler 727/518/904

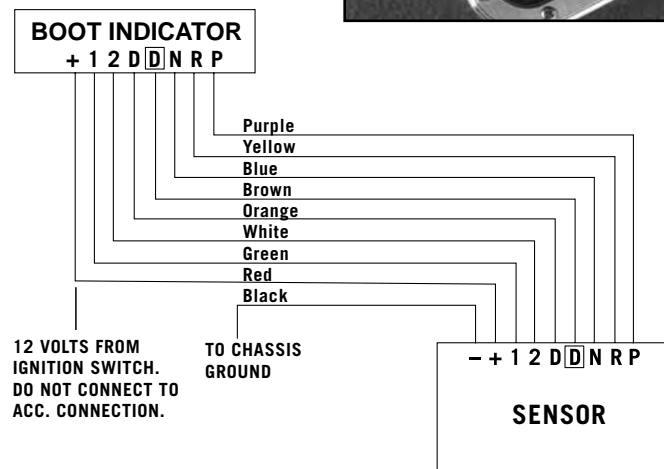

GM 700-R4 & 4L60