



**QUALITY... PLAIN & SIMPLE®**

## Ford C4 Hi-Tech Kickdown Kit Installation Instructions

# Ford C4 Hi-Tech Kickdown Kit Installation Instructions

**Building American Quality... With A Lifetime Warranty!®**

10924 Murdock Dr. • Knoxville, TN 37932

TOLL FREE 1-877-469-7440 • (865) 966-2269 • FAX (865) 671-1999 • tech@lokar.com • www.lokar.com

### General Installation Notes:

Please read instructions completely before beginning installation. If you have any questions please call.

Before starting installation, scotch vehicle tires to avoid accidental movement of the vehicle. Do not attempt to install this product while the engine is running. Disconnect negative battery cable before beginning installation.

Make sure the engine, transmission, body and frame are properly grounded. We recommend applying anti-seize lubricant to all aluminum threads before final assembly.

**NOTE:** This Lokar Kickdown Kit is designed to be installed with Lokar Carburetor Bracket and Springs, part # SRK-4000. The Lokar Kickdown Cable is designed to be cut-to-fit.

Refer to Fig. 1 and Fig. 2 for the component names.

**Step 1:** Remove the cable end stop, kickdown throttle body fitting, and kickdown cable adjuster from the new Lokar kickdown cable. Remove the inner wire from the cable housing, and remove the kickdown lever from the inner wire.

**Step 2:** Install the kickdown lever onto the transmission, with the cable hole towards the transmission as shown in Fig. 3.

**Step 3:** Install the trans cable bracket and the cable housing onto the transmission as shown in Fig. 3.

**Step 4:** If the throttle cable has already been installed, disconnect the throttle cable from the carburetor. If the engine already has a Lokar carburetor bracket installed, remove the throttle cable adjuster. Leave the carburetor bracket in place. If the engine does not have a Lokar Carburetor Bracket already installed, install one now, following the installation instructions that were provided with the Lokar Carburetor Bracket.

**Step 5:** The kickdown mounting bracket mounts onto the back side of the Lokar carburetor bracket. The throttle cable adjuster will pass through the top hole in both the new kickdown mounting bracket AND the carburetor bracket.

Position the kickdown mounting bracket behind the carburetor bracket so that the 5/16" diameter holes at the top of both brackets are aligned, the small 3/16" diameter holes near the center of the two brackets are aligned, and the lower 5/16" diameter hole in the kickdown mounting bracket is offset towards the left side of the vehicle.

Attach the kickdown mounting bracket to the carburetor bracket using the supplied #8-32 x 1/2" button head bolt and nylock nut through the small 3/16" diameter center holes in both brackets, but do not tighten yet. Insert the throttle cable adjuster (with the rear nut still installed) from the rear through the top holes in both brackets. Position it so that the bracket is roughly centered in the threaded part of the cable adjuster. Install the front adjuster nut but do not tighten yet.

Insert the kickdown cable adjuster (with the rear adjuster nut still installed) from the rear into the open hole in the bottom of the kickdown mounting bracket. Position it so that the bracket is roughly centered in the threaded part of the cable adjuster. Install the front adjuster nut.

Tighten the throttle cable adjuster nuts, the button head bolt and nut, and the kickdown cable adjuster nuts. Fig. 4

**Step 6:** Route the cable housing up to the kickdown cable adjuster. Make sure that the inner wire is removed from the cable housing. If the cable housing is braided stainless steel, slide the ferrule down the housing towards the transmission, away from the end that is being cut. **DO NOT** remove the ferrule from a braided stainless steel housing! If the cable housing is black universal, remove the ferrule.

Measure the distance between the kickdown cable adjuster and the trans cable bracket. Add 1" to the measurement and cut the cable housing to that length.

If the kickdown cable has a braided stainless steel housing, wrap tape around the area to be cut and use an abrasive cutoff saw or fine-toothed hacksaw. If the kickdown cable has a black universal housing, cut the cable housing with heavy duty 8" diagonal cutting pliers or a hacksaw. Lokar recommends Klein brand Diagonal Cutting Pliers, # 2-2000-28 available at The Home Depot or through W. W. Graingers, Part # 4A838.

After cutting the cable housing, put the ferrule back in place at the end of the cable housing. Insert the cable housing and ferrule into the kickdown cable adjuster.

**Step 7:** The tear drop will be attached to the carburetor throttle arm by the hex carb fitting. Separate the hex carb fitting from the kickdown throttle body fitting. Install the hex carb fitting and the tear drop onto the carburetor throttle arm as shown in Fig. 5. Hook the springs to the tear drop and tighten the hex carb fitting.

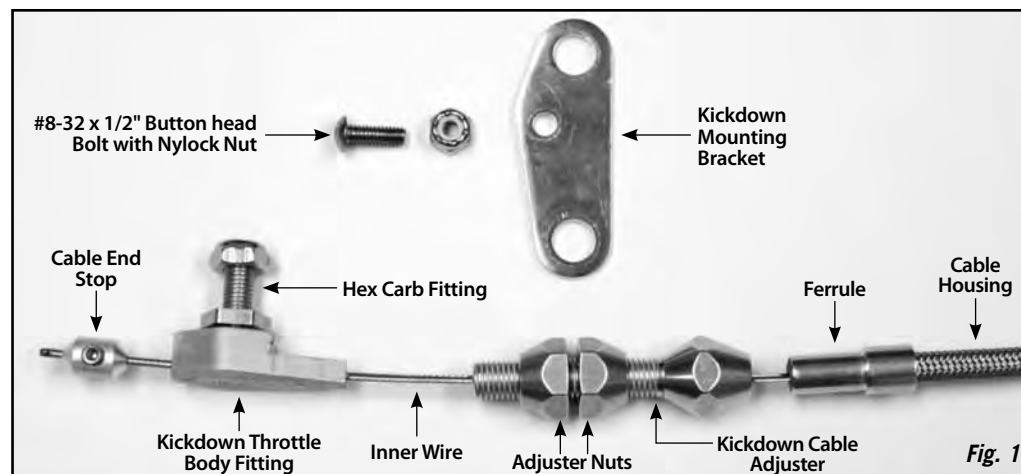

Fig. 1



QUALITY... PLAIN & SIMPLE®

### Ford C4 Hi-Tech Kickdown Kit Installation Instructions

# Ford C4 Hi-Tech Kickdown Kit Installation Instructions

Building American Quality... With A Lifetime Warranty!®

10924 Murdock Dr. • Knoxville, TN 37932

TOLL FREE 1-877-469-7440 • (865) 966-2269 • FAX (865) 671-1999 • tech@lokar.com • www.lokar.com

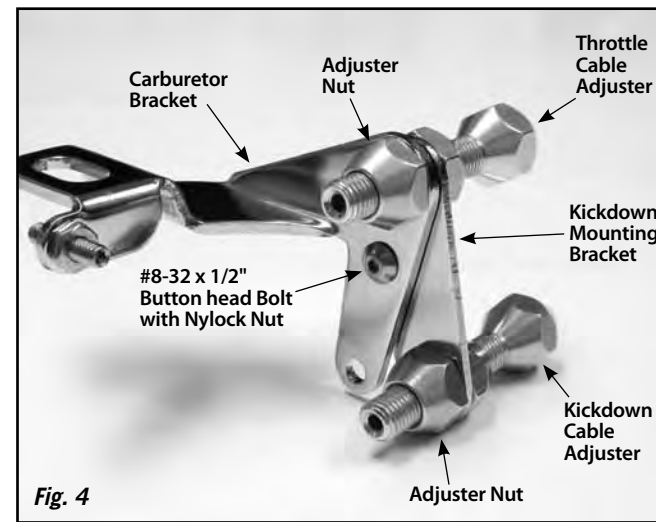
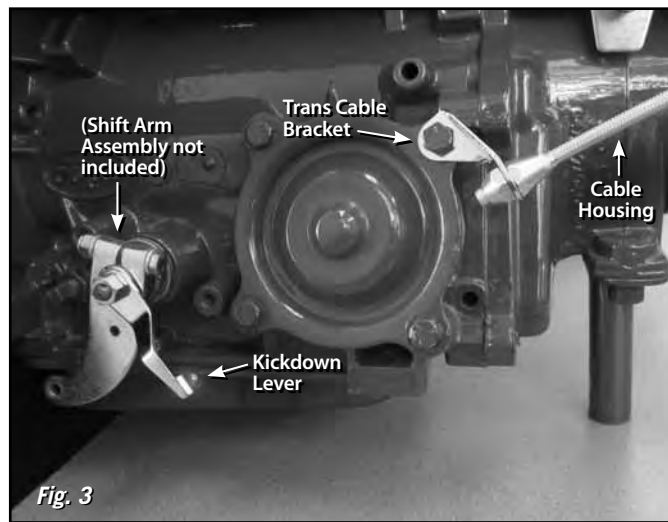
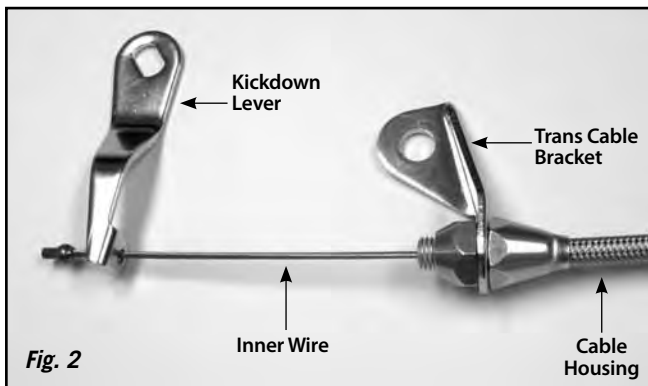

**Step 8:** Pass the inner wire through the hole in the kickdown lever on the transmission, and then thread it up through the cable housing. Slide the kickdown throttle body fitting onto the inner wire, and connect the kickdown throttle body fitting to the hex carb fitting.

**Step 9:** Slide the kickdown cable end stop onto the inner wire. Move the throttle to wide open and pull the kickdown inner wire as tight as possible. Slide the cable end stop up against the kickdown throttle body fitting and tighten the set screw using the supplied Allen wrench. Release the throttle. When the kickdown cable is properly adjusted you should be able to open the throttle to the wide open position without interference from the kickdown cable; and with the throttle wide open, you should not be able to pull the kickdown cable any further.

Double check to be sure that all carburetor, throttle and kickdown linkage operates freely without binding, then test drive. Once the kickdown cable is correctly adjusted and operating properly you can cut off the excess inner wire, leaving about 1/2" extending beyond the cable end stop to allow for future adjustment if needed.

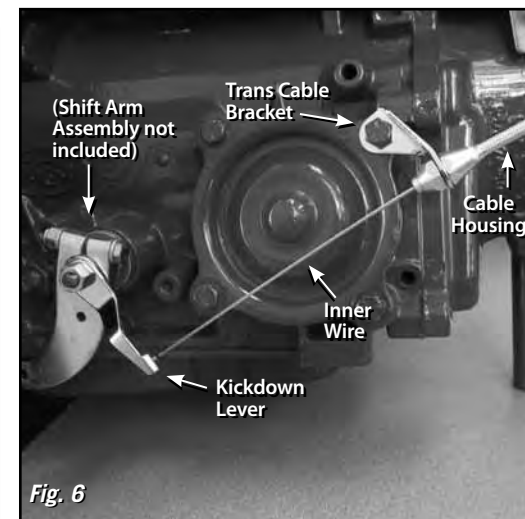
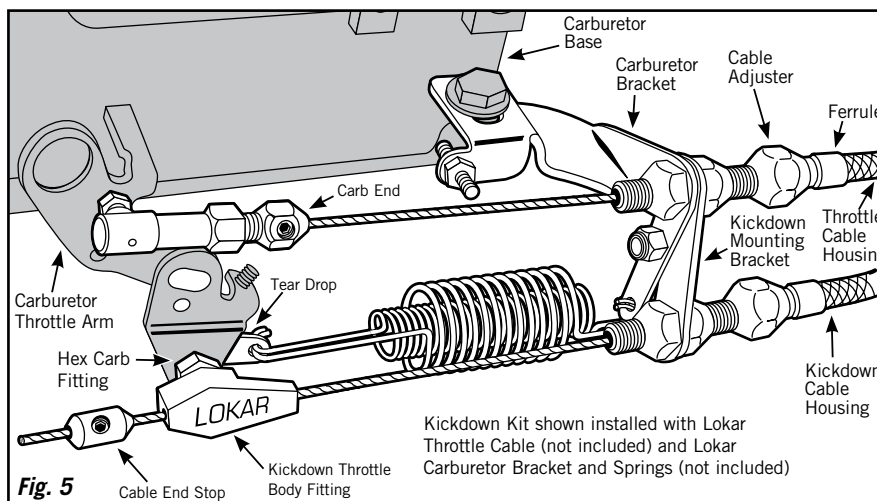

Kickdown Kit shown installed with Lokar Throttle Cable (not included) and Lokar Carburetor Bracket and Springs (not included)

Final installation should look like Fig. 5 and Fig. 6.