



QUALITY... PLAIN & SIMPLE®

Column Shift Linkage Installation Instructions

For GM TH350, TH400, 700-R4, TH200, 200-4R, 4L60, 4L60E, 4L80E, and 6L80E/6L90E

General Installation Notes:

Please read these instructions completely before beginning the installation. If you have any questions, please call.

Before beginning the installation, disconnect the negative battery cable and use wheel chocks to block the vehicle's wheels.

Make sure the engine, transmission, body and frame are properly grounded. We recommend using anti-seize lubricant on all aluminum threads.

All Lokar Installation Instructions can be found by visiting www.lokar.com/instructions.html.

Lokar Column Shift Linkage is designed to work with GM style factory or aftermarket column shift steering columns. The stainless steel rod is designed to be cut to fit individual applications. The kit comes with either a 21" rod or a 26" rod, depending on your part number. The 26" rod is also available for purchase separately (Lokar part #ATA-1837). The Lokar Column Shift Linkage is designed with identical rod ends so the hex connector can be used at either end of the stainless steel rod for clearance purposes.

This Kit will NOT work with the Lokar Backup Light or Neutral Safety Switch Kit #BL-1400U on TH400, 700-R4, 4L60, 4L60E, 4L80E, 6L80E, and 6L90E transmissions.

Refer to Figs. 1, 2 and 3 for the component names.

Step 1: Put the shifter and transmission selector shaft into the Park position. Remove any existing linkage from the transmission selector shaft and the steering column.

Step 2: Install the splined trans arm bushing onto the transmission selector shaft with the open end facing out. Make sure the flats in the bushing are aligned with the flats on the selector shaft. This kit includes two trans arm nuts, one metric 10mm (has nicks on hex) and one standard 3/8"-16 (except 6L80E/6L90E comes with 10mm only). Using the proper trans arm nut for your application, tighten the splined trans arm bushing onto the transmission selector shaft.

Step 3: Install the adjustable trans arm onto the splined trans arm bushing at approximately the 8:00 position as a starting point, with the wide slot on the side towards the transmission and the narrow slot on the side away from the transmission. See Fig. 2, Fig. 3, Fig. 4, and Fig. 5. The positioning varies per application, and it may be necessary to reposition the arm in order to be able to get the transmission into all gear positions.

Column Shift Linkage Installation Instructions

For GM TH350, TH400, 700-R4, TH200, 200-4R, 4L60, 4L60E, 4L80E, and 6L80E/6L90E

Building American Quality... With A Lifetime Warranty!®

TOLL FREE 1-877-469-7440 • tech@lokar.com • www.lokar.com

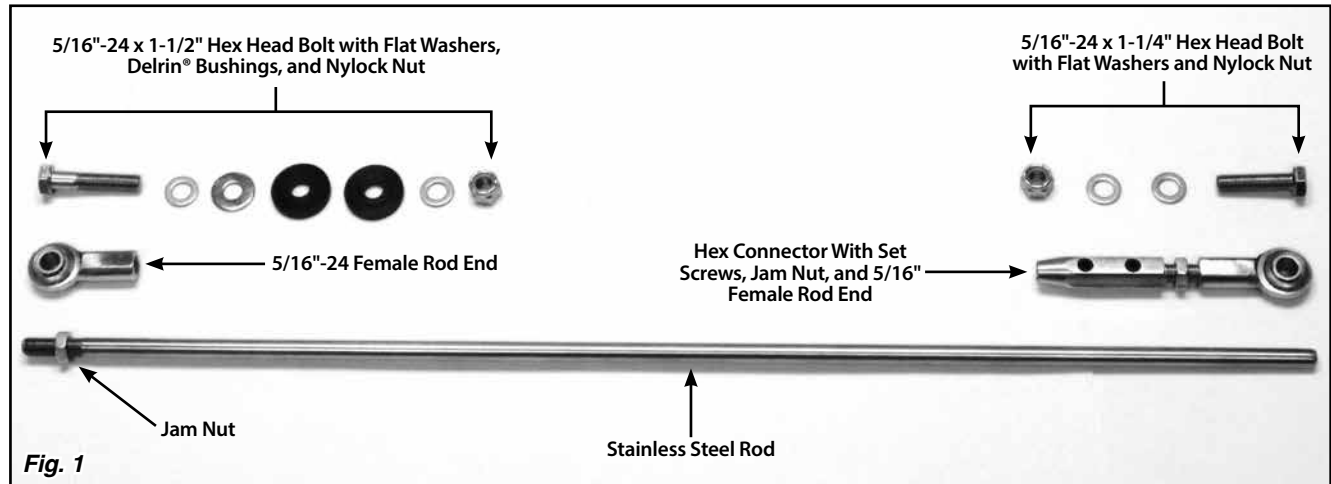

Fig. 1



Fig. 2

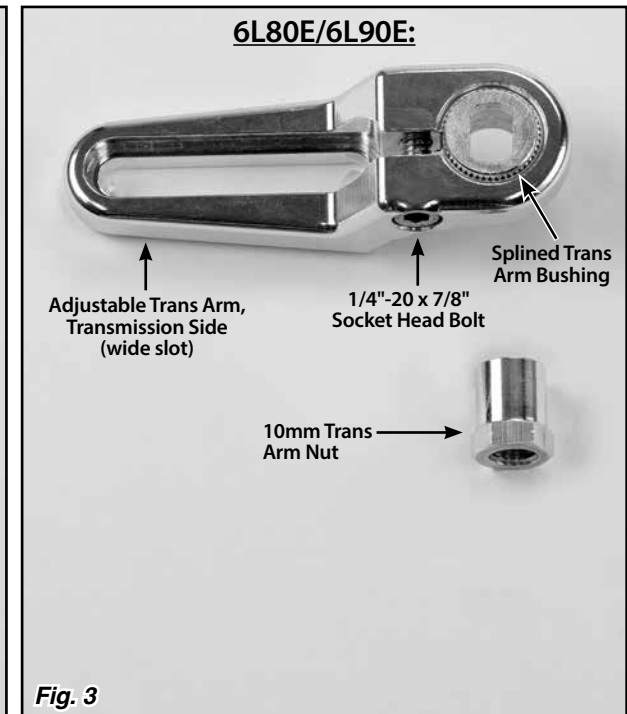

Fig. 3

Step 4: The steering column arm could be one of several different designs, and the type of steering column arm you have will determine how the Delrin® bushings will be positioned. If the raised shoulder in the center of the provided Delrin bushings will fit inside the hole in the steering column arm, the Delrin bushings will be installed with the raised center shoulders facing each other inside the steering column arm. If the raised shoulder in the center of the provided Delrin bushings will **NOT** fit inside the hole in the steering column arm, the Delrin bushings will be installed with the raised center shoulders facing outwards.

NOTE: Some aftermarket steering columns may require you to drill out the steering column arm to fit the bushings. The new hole diameter should be 0.625" (5/8").

Install a small flat washer onto the 5/16"-24 x 1-1/2" bolt. Slide the bolt through the 5/16"-24 female rod end. Next, install the large diameter flat washer onto the bolt, and one Delrin bushing facing the proper direction. Insert the bolt through the steering column arm, and install the other Delrin bushing and small flat washer. Secure it all using the 5/16"-24 nylock nut as shown in **Fig. 6**.

NOTE: These items can be installed in the reverse order if necessary for clearance or proper alignment.

Step 5: Thread the stainless steel rod into the rod end on the steering column arm, leaving about 1/4" of threads exposed beyond the jam nut.

Step 6: Check to make sure nothing will interfere with connecting the stainless steel rod to the adjustable trans arm. If required, the stainless steel rod can be bent to clear other components, starting at the steering column end.

Step 7: Line up the transmission end of the stainless steel rod with the center of the slot in the adjustable trans arm, and mark the stainless steel rod at the center of the adjustable trans arm slot. Measure 1-3/4" back towards the column end from your mark, and cut the stainless steel rod at that point using a cutoff wheel or saw.

Step 8: Slide the hex connector with the second 5/16"-24 female rod end onto the end of the stainless steel rod. Attach the rod end to the adjustable trans arm with the 5/16"-24 x 1-1/4" hex head bolt, two flat washers, and nylock nut as shown in **Fig. 6**. Tighten the nylock nut. Tighten the set screws in the hex connector using a 1/8" Allen wrench, but only enough to mark the stainless steel rod and hold the hex connector in place during the adjustment procedure.

Step 9: Adjust the shift linkage so the shift lever will enable you to get the transmission into all gear ranges. Once you have the final adjustment done, tighten the jam nuts at both ends of the stainless steel rod. Use a 3/16" Allen wrench to tighten the 1/4"-20 x 7/8" socket head bolt on the adjustable trans arm to clamp it to the trans arm bushing.

Step 10: Disconnect the stainless steel rod from the hex connector and grind two small flat spots on the rod where each of the set screws contact it (this will help maintain the position of the rod). Apply thread locking compound (not supplied) to the set screws. Then, install and tighten them.

NOTE: Also included in this kit (except 6L80E/6L90E) are two standoff bolts, a 10mm (has nicks on hex) and a 3/8"-16. These bolts are only used with the Lokar Part No. BL-1400U, Back-Up Light or Neutral Safety Switch Kit. These are to retain the back-up light or neutral safety switch trigger to the selector shaft.

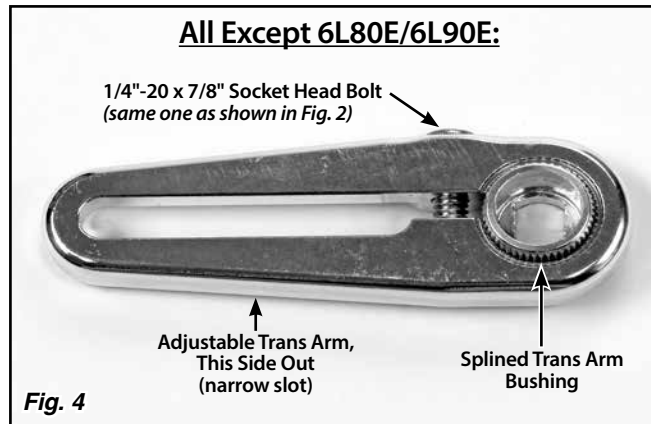

Fig. 4

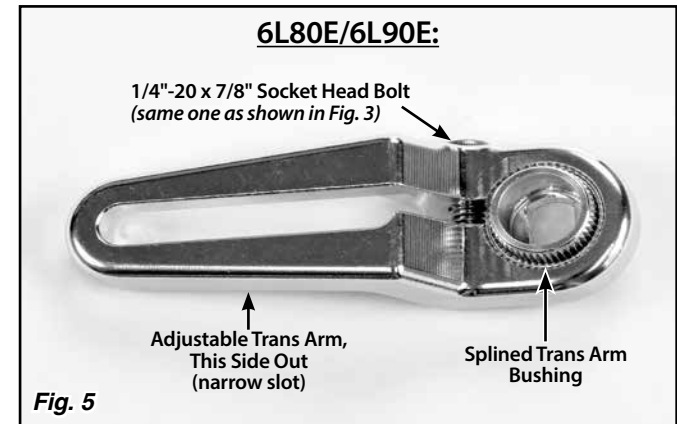

Fig. 5

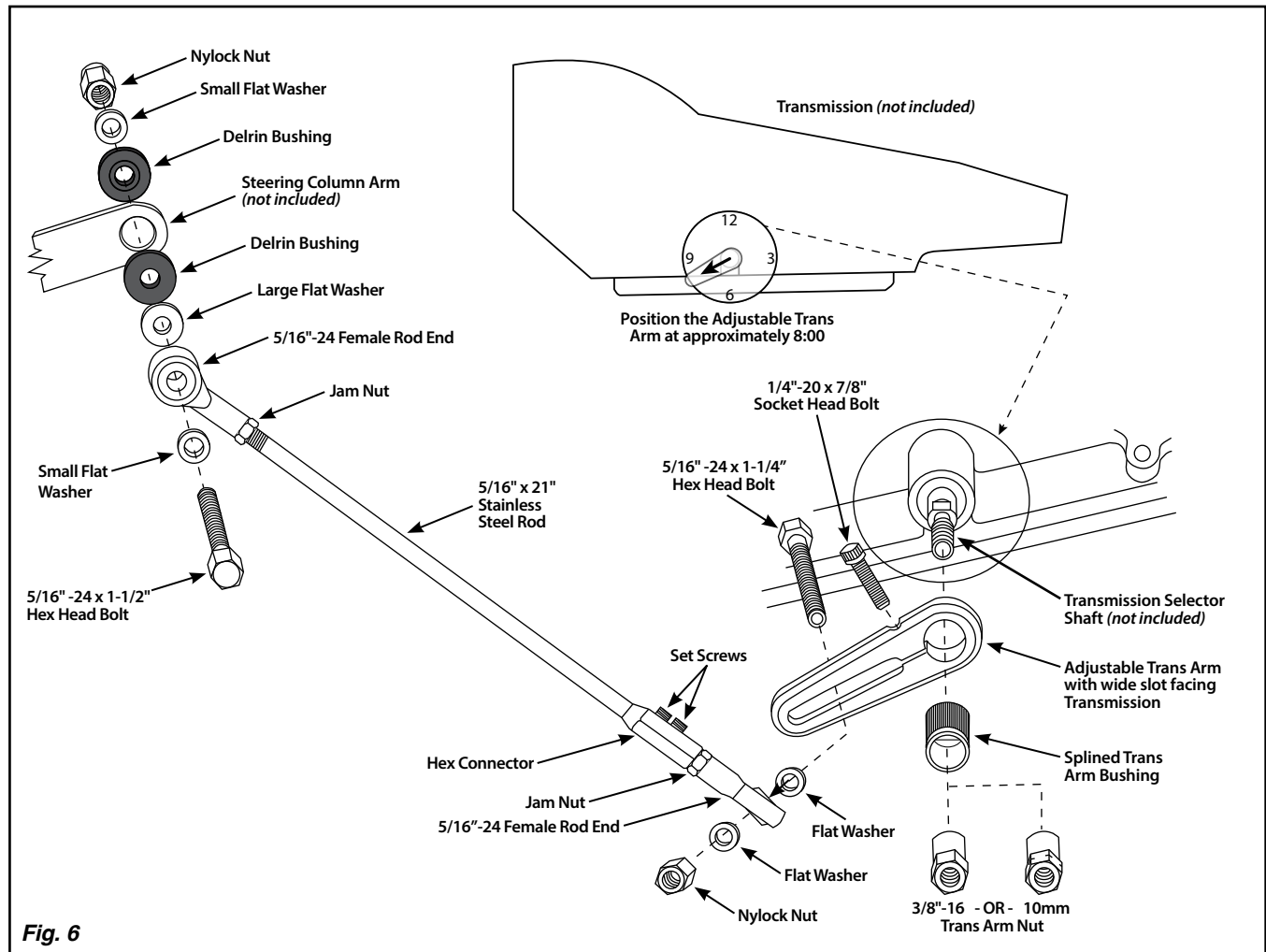

Fig. 6