



# EZ Bracket Kit







Chevy Colorado  
Crew Cab

Part Number  
300041

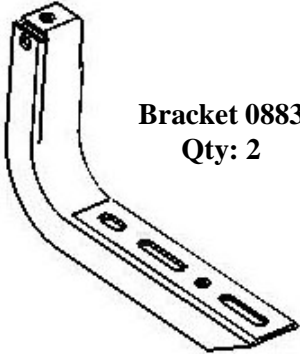
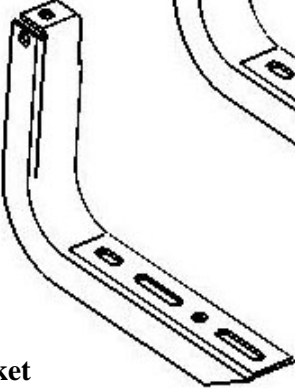
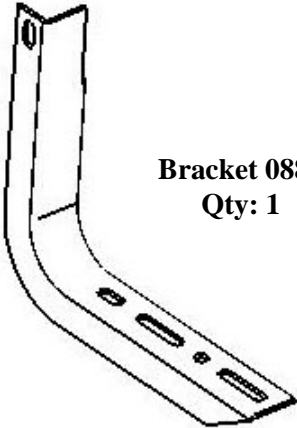
Thank you for purchasing one of the many quality items manufactured by Lund International. We take the utmost pride in our products and want you to enjoy years of satisfaction from your investment.

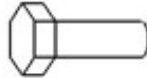
## Caution

To avoid risk of injury and/or property damage to you and others on the highway, read and follow all Running Board and EZ bracket instructions & vehicle owner's manual before installing the EZ Bracket System on your vehicle.

INSTALLATION KIT INCLUDES		
 <p><b>Bracket 0883</b> Qty: 2</p>  <p><b>Bracket 0884</b> Qty: 3</p>  <p><b>Bracket 0886</b> Qty: 1</p>	    	<p>1/4" Self-Tapping Screw</p> <p>1/4" x 1" Bolt</p> <p>1/4" washer</p> <p>1/4" Nylock Nut</p> <p>Pinch Weld Bracket Qty: 6</p>

©2003 Lund International, Inc. Lund Accessories Division, All Rights Reserved

775 Tipton Industrial, Lawrenceville, GA 30045

For customer service, please call 1-800-328-4843

For more information about Lund, please visit our website at [www.lundinternational.com](http://www.lundinternational.com)

PN: 45041\_A

## TOOLS NEEDED FOR INSTALLATION

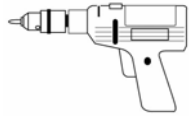

**Drill**



**Standard Socket Set**

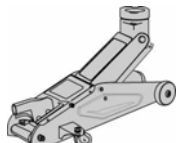

**Floor Jack**



**Center Punch**



**Silicone**



**1/8" Drill bit**



**5/16" Drill bit**

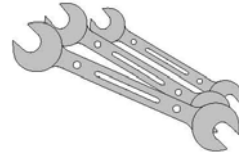

**Standard Wrench Set**



**Hammer**

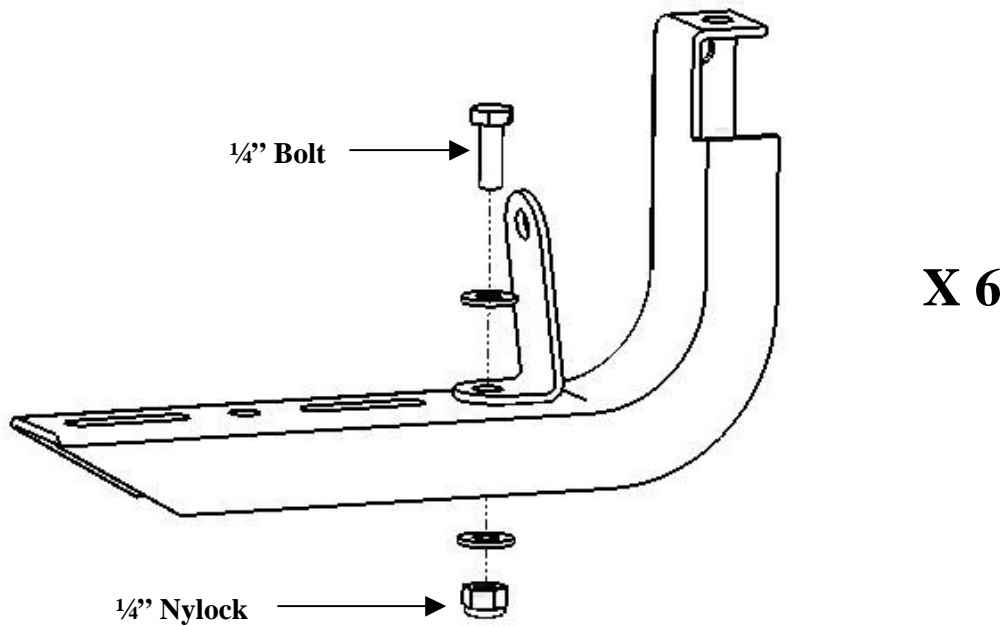

- 1. Assemble brackets as shown above. Do not tighten.**
- 2. Assemble brackets to pre-assembled running board (per running board instructions) do not tighten yet. Refer to step 3 for bracket placement.**
- 3. Place brackets in mounting locations as shown below. Mark, center punch, drill and attach and tighten as noted. NOTE: PLACE A SMALL BEAD OF SILICONE IN ALL DRILLED HOLES.**

**Front Brackets:**

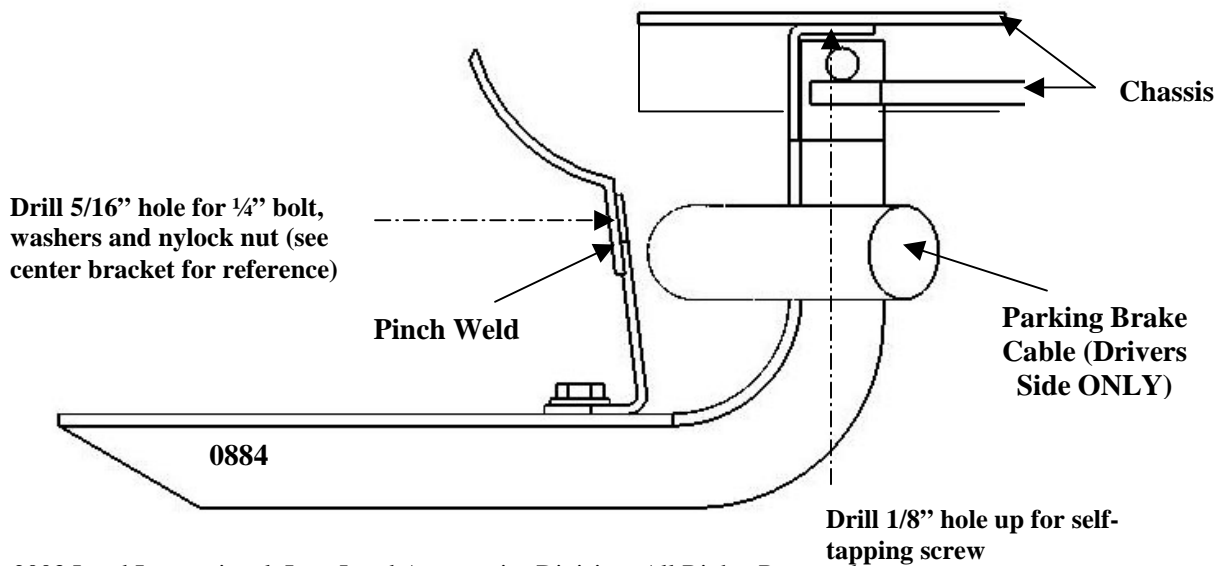

2003 Lund International, Inc. Lund Accessories Division, All Rights Reserved  
 775 Tipton Industrial, Lawrenceville, GA 30045  
 For customer service, please call 1-800-328-4843  
 For more information about Lund, please visit our website at [www.lundinternational.com](http://www.lundinternational.com)  
 PN: 45041

**Center Brackets:**

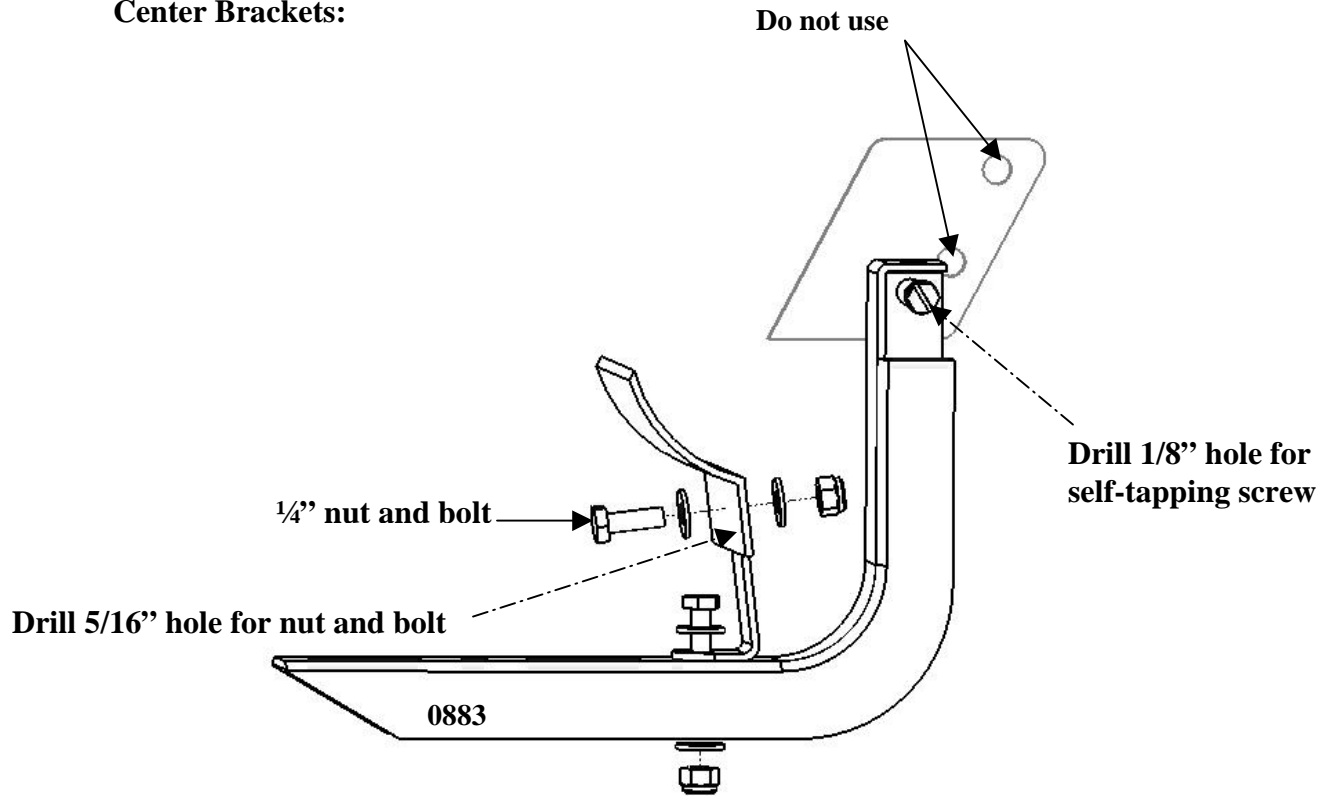

**Drivers Rear Bracket Assembly:**

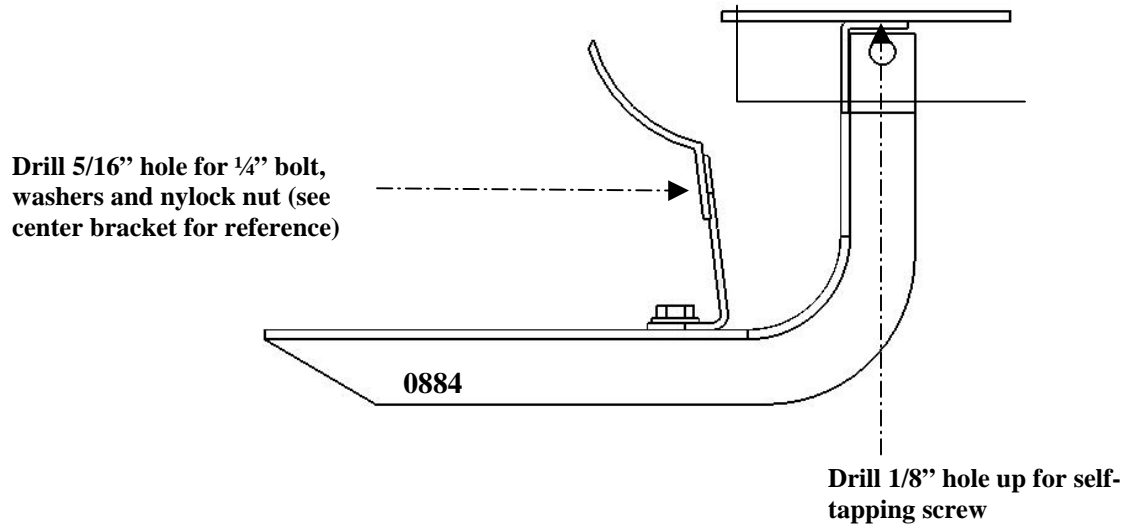

2003 Lund International, Inc. Lund Accessories Division, All Rights Reserved  
775 Tipton Industrial, Lawrenceville, GA 30045  
For customer service, please call 1-800-328-4843  
For more information about Lund, please visit our website at [www.lundinternational.com](http://www.lundinternational.com)  
PN: 45041\_A

### Passenger Rear Bracket Assembly:

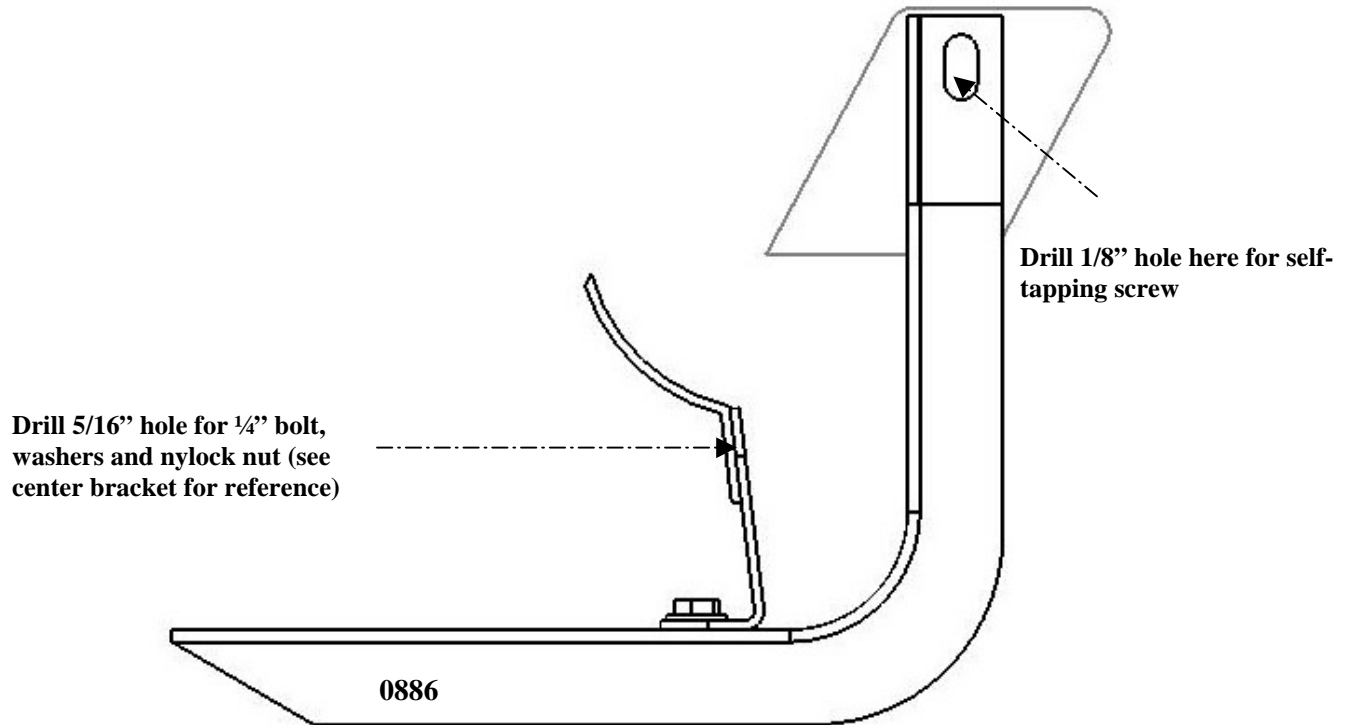

4. Tighten the pinch weld bracket to the main brackets.
5. Center the board on the truck and then tighten the board to the main brackets.
6. Double check to be sure all nuts and bolts are tight.

### **PRODUCT SPECIFIC WARNINGS:**

- Do not stand on boards while vehicle is in motion
- Do not use boards to fasten cargo to vehicle
- Do not exceed 350lbs weight on the running board
- Do not use the bracket as a jacking point
- Periodically check the bracket hardware for tightness

2003 Lund International, Inc. Lund Accessories Division, All Rights Reserved  
775 Tipton Industrial, Lawrenceville, GA 30045  
For customer service, please call 1-800-328-4843  
For more information about Lund, please visit our website at [www.lundinternational.com](http://www.lundinternational.com)  
PN: 45041\_A



Chevy Colorado  
cabine d'équipage

# Trousse pour support EZ







Part Number  
300041

Merci d'avoir acheté un des nombreux produits de qualité fabriqués par Lund International. Nous sommes extrêmement fiers de nos produits et nous espérons que vous profiterez de plusieurs années de satisfaction de votre investissement.

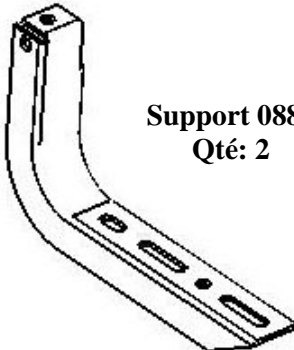
## Mise en garde

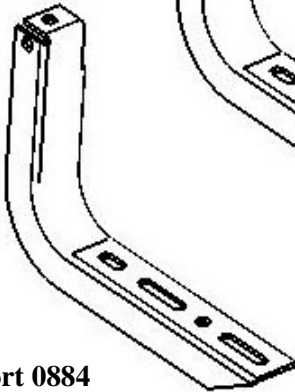
En vue d'éviter les risques de blessures et de dommages matériels pour vous et les autres sur l'autoroute, veuillez lire et suivre toutes les directives du marchepied et du support EZ ainsi que le manuel d'utilisation du véhicule avant d'installer le système de support EZ sur votre véhicule.

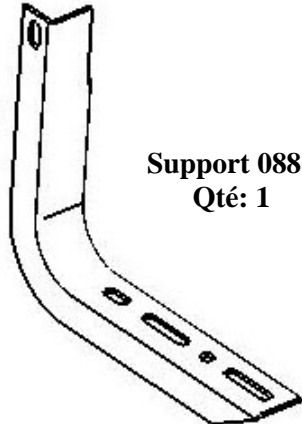
## LA TROUSSE D'INSTALLATION COMPREND

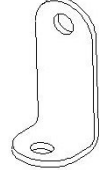
 Support 0883 Qté: 2		Vis autotaraudeuse de 6 mm
 Support 0884 Qté: 3		Boulon de 6 mm x 25 mm
 Support 0886 Qté: 1		Rondelle de 6 mm
		Écrou à frein élastique de 6 mm
		Support à joint de soudure Qté : 6

2003 Lund International, Inc. Lund Accessories Division, tous droits réservés.

775 Tipton Industrial, Lawrenceville, GA 30045

Pour communiquer avec le service à la clientèle, composer le 1 800 328-4843.

Pour obtenir de plus amples renseignements au sujet de Lund, veuillez visiter notre site Web à [www.lundinternational.com](http://www.lundinternational.com).

N° de pièce : 45041\_A

## OUTILS REQUIS POUR L'INSTALLATION



**Perceuse**



**Jeu de douilles standard**

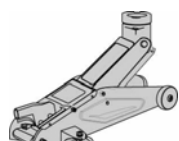

**Cric rouleur**



**Pointeau**



**Silicone**



**Trépan de 3 mm**



**Trépan de 8 mm**

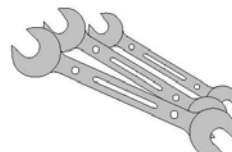

**Jeu de clés standard**



**Marteau**

2003 Lund International, Inc. Lund Accessories Division, tous droits réservés.

775 Tipton Industrial, Lawrenceville, GA 30045

Pour communiquer avec le service à la clientèle, composer le 1 800 328-4843.

Pour obtenir de plus amples renseignements au sujet de Lund, veuillez visiter notre site Web à [www.lundinternational.com](http://www.lundinternational.com).

N° de pièce : 45041\_A

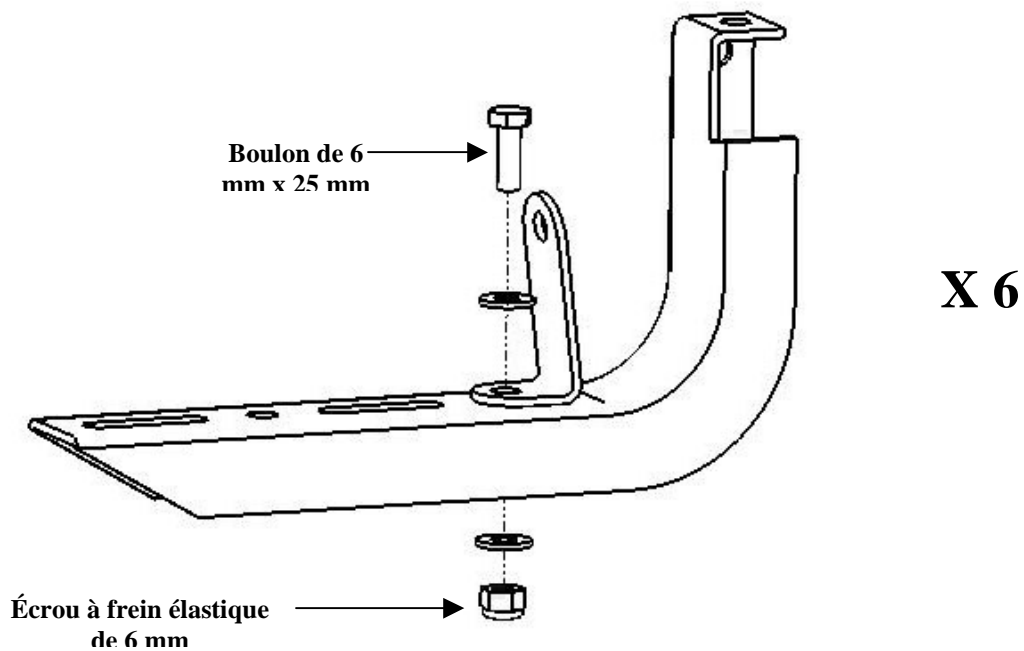

- 1. Assembler les supports comme dans l'illustration ci-dessus. Ne pas serrer.**
- 2. Assembler les supports sur le marchepied préassemblé (selon les directives du marchepied). Ne pas serrer tout de suite. Se reporter à l'étape 3 pour savoir où placer le support.**
- 3. Placer les supports aux endroits de montage indiqués ci-dessous. Marquer, pointer, percer, fixer et serrer tel qu'indiqué. REMARQUE : PLACER UN PETIT BOUDIN DE SILICONE DANS TOUS LES TROUS PERCÉS.**



**Supports avant :**

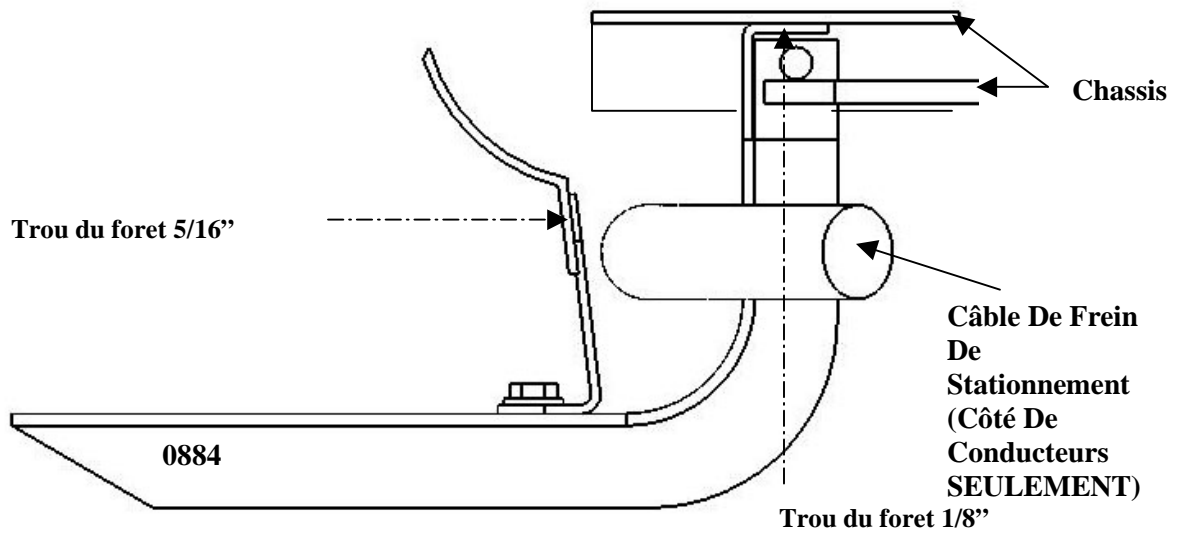

**Supports centraux :**

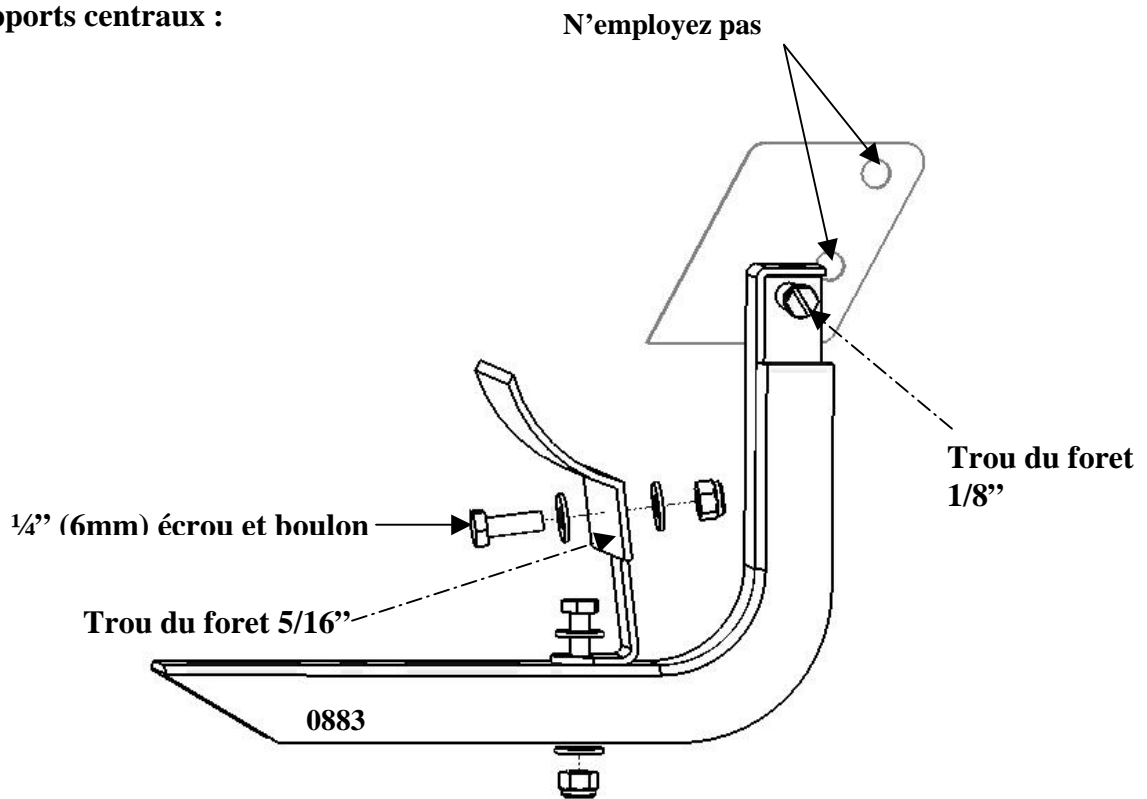

2003 Lund International, Inc. Lund Accessories Division, tous droits réservés.  
775 Tipton Industrial, Lawrenceville, GA 30045  
Pour communiquer avec le service à la clientèle, composer le 1 800 328-4843.  
Pour obtenir de plus amples renseignements au sujet de Lund, veuillez visiter notre site Web à [www.lundinternational.com](http://www.lundinternational.com).  
N° de pièce : 45041\_A

### Montage du support arrière du conducteur :

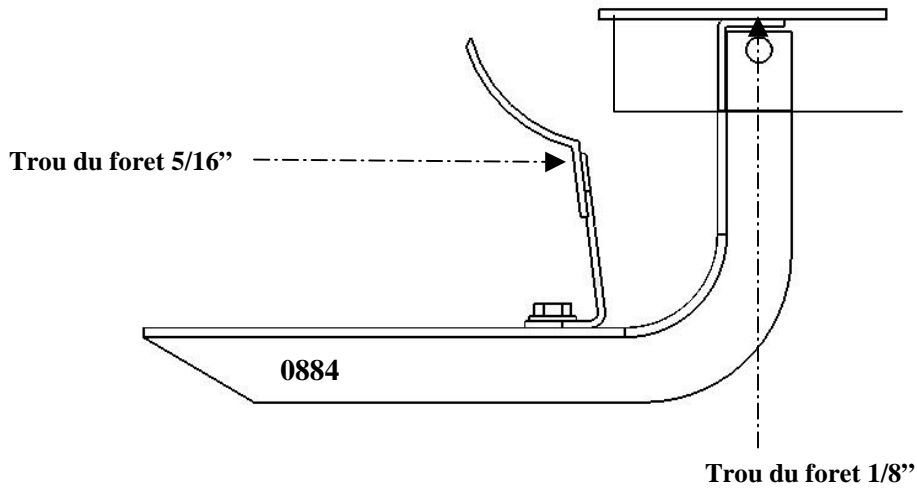

### Montage du support arrière du passager :

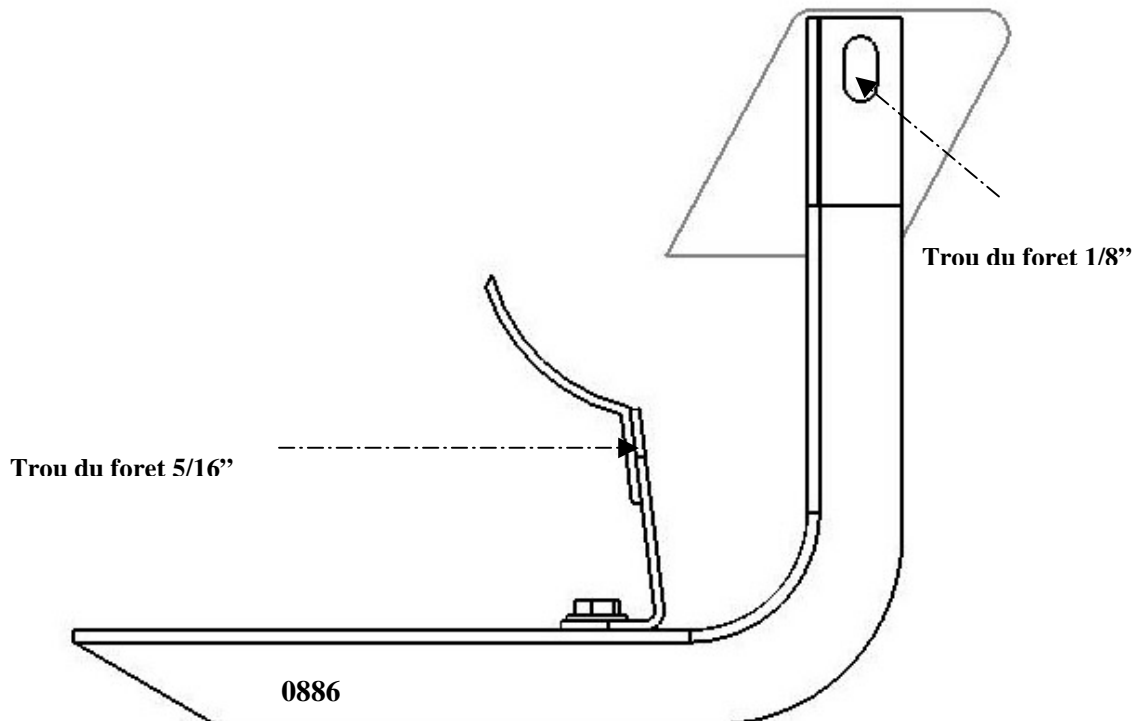

2003 Lund International, Inc. Lund Accessories Division, tous droits réservés.  
775 Tipton Industrial, Lawrenceville, GA 30045  
Pour communiquer avec le service à la clientèle, composer le 1 800 328-4843.  
Pour obtenir de plus amples renseignements au sujet de Lund, veuillez visiter notre site Web à [www.lundinternational.com](http://www.lundinternational.com).  
N° de pièce : 45041\_A

4. **Serrer le support à joint de soudure aux supports principaux.**
5. **Centrer le marchepied sur le camion et le serrer sur les supports principaux.**
6. **Vérifier à nouveau pour s'assurer que tous les écrous et boulons sont bien serrés.**

**AVERTISSEMENTS SPÉCIFIQUES AU PRODUIT :**

- Ne pas se tenir sur les marchepieds lorsque le véhicule se déplace.
- Ne pas utiliser les marchepieds pour fixer une cargaison au véhicule.
- Ne pas excéder 158 kg (350 lb) de pesanteur sur le marchepied.
- Ne pas utiliser le support comme point de levage.
- S'assurer périodiquement que la quincaillerie du support est bien serrée.



# Juego de soporte EZ





Chevy Colorado  
Cab. Doble

PN: 300041

Gracias por comprar uno de los muchos artículos de calidad fabricados por Lund International. Nuestros productos nos enorgullecen en gran manera y deseamos que usted disfrute de años de satisfacción en su inversión.

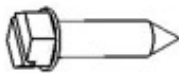
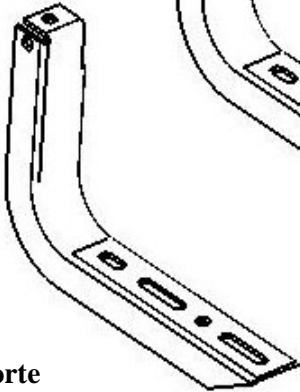
## Precaución

Para evitar todo riesgo de sufrir lesiones y/o daños en su propiedad y en la de otros en la carretera, lea y siga todas las instrucciones del soporte EZ, del estribo y del manual del propietario del vehículo antes de instalar el Sistema de Soporte EZ en el vehículo.

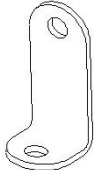
<b>EL JUEGO DE INSTALACIÓN INCLUYE</b>			
	<b>Soporte 0883</b> Cantidad: 2		<b>Tornillo autorroscante de ¼ pulg. (6.3mm)</b>
	<b>Soporte 0884</b> Cantidad: 3		<b>Perno de ¼ pulg. x 1 pulg. (6.3mm x 2.54cm)</b>
	<b>Soporte 0886</b> Cantidad: 1		<b>Arandela de ¼ pulg. (6.3mm)</b>
			<b>Tuerca Nylock de ¼ pulg. (6.3mm)</b>
			<b>Soporte para apretar la soldadura</b> Cantidad: 6

2003 Lund International, Inc. División Accesorios de Lund, Todos los derechos reservados

775 Tipton Industrial, Lawrenceville, GA 30045

Para atención al cliente, por favor llame al 1-800-328-4843

Para obtener más información sobre Lund, por favor visite nuestro sitio web en [www.lundinternational.com](http://www.lundinternational.com)

PN: 45041\_A

## HERRAMIENTAS NECESARIAS PARA LA INSTALACIÓN

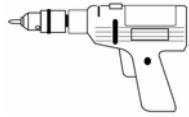

**Taladro**



**Juego de llaves de cubo estándar**

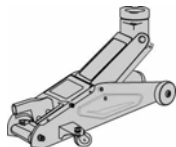

**Gato de piso**



**Punzón de marcar**



**Silicona**



**Broca de 1/8 pulg. (3.1mm)**



**Broca de 5/16 pulg. (7.9mm)**

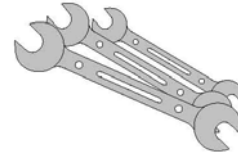

**Juego de llaves de tuercas estándar**



**Martillo**

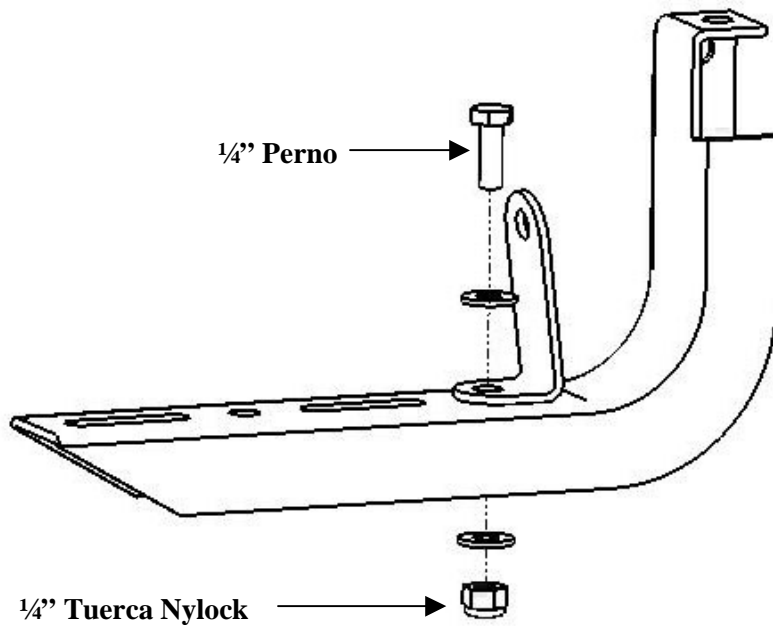

**X 6**

- 1. Arme los soportes como se mostró anteriormente. No apriete demasiado.**
- 2. Ensamble los soportes a los estribos pre-armados (según las instrucciones de los estribos), no los apriete todavía. Vaya al paso 3 para obtener la ubicación de los soportes.**
- 3. Coloque los soportes en las ubicaciones de montaje como se muestra más abajo. Marque con punzón de marcar, perforo, ajuste y apriete según se observa. NOTA: COLOQUE UNA GOTA DE SILICONA EN TODOS LOS ORIFICIOS PERFORADOS.**

**Soportes frontales:**

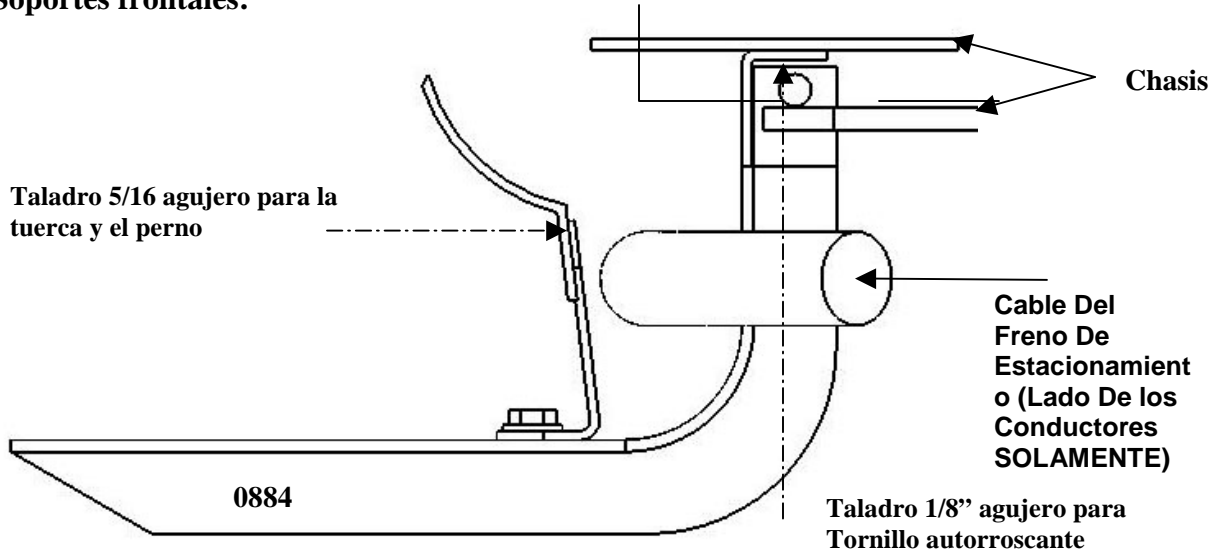

**Soporte centrales:**

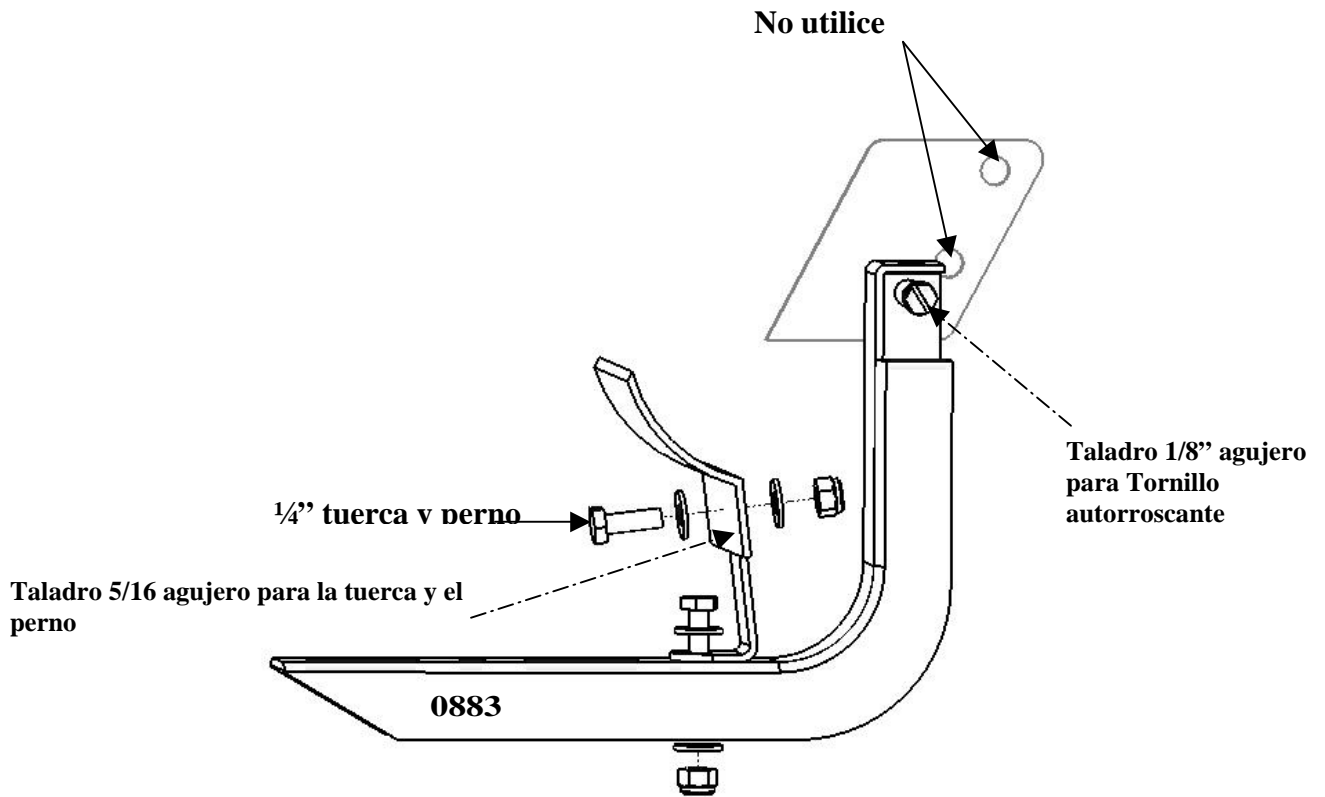

2003 Lund International, Inc. División Accesorios de Lund, Todos los derechos reservados  
775 Tipton Industrial, Lawrenceville, GA 30045  
Para atención al cliente, por favor llame al 1-800-328-4843  
Para obtener más información sobre Lund, por favor visite nuestro sitio web en [www.lundinternational.com](http://www.lundinternational.com)  
PN: 45041\_A

### Armado del soporte trasero del conductor:

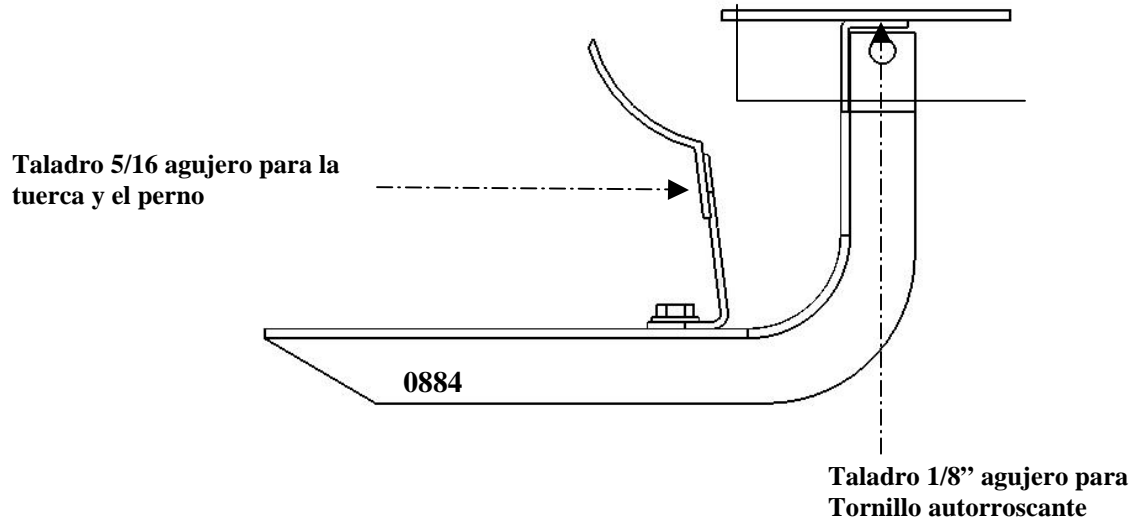

### Armado del soporte trasero del pasajero:

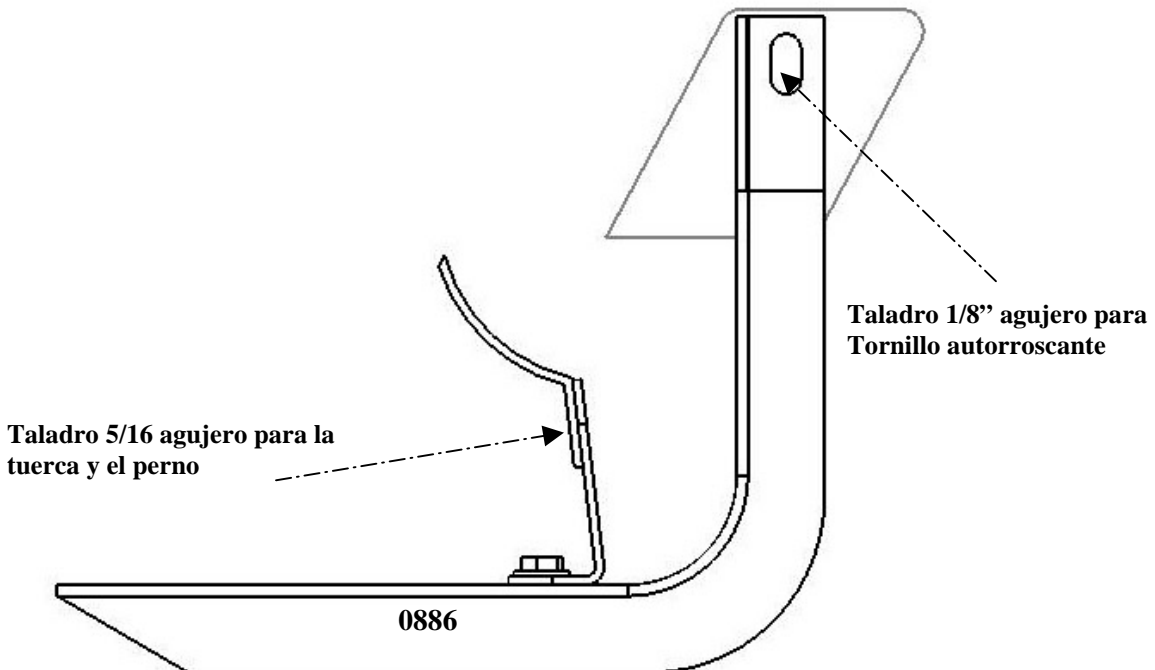



- 4. Ajuste el soporte para apretar la soldadura a los soportes principales.**
- 5. Centre el panel en la camioneta y luego ajústelo a los soportes principales.**
- 6. Verifique dos veces que todas las tuercas y pernos estén apretados.**

**ADVERTENCIAS ESPECÍFICAS DEL PRODUCTO:**

- No permanezca en los paneles mientras el vehículo esté en movimiento**
- No utilice los paneles para sujetar la carga al vehículo**
- No supere las 350lbs (159kg) de peso sobre el panel**
- No utilice el soporte como punto para levantar el gato**
- Controle periódicamente que el soporte esté ajustado**