

Care and Cleaning

To keep your billet grille looking their best, we recommend using only mild soap and water and a soft cotton cloth to wash and dry it. Use of rough cleaning agents or cloths may scratch or dull your billet grille.

Should your billet grille become scratched or dull, we recommend TRENZ® Metal Polish to bring back the mirror finish. There are three grades of TRENZ® Metal Polish (Coarse, Medium and Fine) that will help you keep your billet grille looking brand new. Select the TRENZ® Metal Polishes best for your needs:

1. Course (Red) Polish – For severe scratches and pitted problems.
2. Medium (Green) Polish – For light scratches and dulling problems.
3. Fine (White) Polish – To bring back the mirror finish.

TRENZ® Metal Polish can be used on all metal products, including aluminum, stainless steel, brass and copper. If you have additional questions or concerns on the maintenance of your Lund® billet grille, please call us at 800-328-5863. You may also use high quality commercially available polish recommended for aluminum accessories.

Congratulations!

You have purchased one of many quality Lund® branded products offered by Lund International, Inc. We take the utmost pride in our products and want you to enjoy years of satisfaction from your investment. We have made every effort to ensure that your product is top quality in terms of fit, durability, finish and ease of installation.



Lund International, Lund Accessories Division
775 Tipton Industrial Drive, Building 2, Suite F
Lawrenceville, GA 30045

Phone 800-328-5863 • Fax 800-782-5448 • Visit us at lundinternational.com

© 2005 Lund International, Inc. All rights reserved.
Lund® and the Lund® logo are trademarks of Lund International, Inc.



Installation Instructions

Part Number 84005

I-sheet Rev. A2



Original Bar Grille

For proper installation and best possible fit, please read all instructions BEFORE you begin.
For technical assistance or to obtain missing parts, please call Customer Relations at 1-800-328-5863.

Important Safety Information



CAUTION
PRECAUCIÓN
ATTENTION

To avoid risk of personal injury or property damage:

- Wear safety glasses and gloves while installing billet inserts.
- Use caution when working with any power tools.
- Check clearance on vehicle.
- Make sure that the billet inserts are secured in place and clears all moving parts of the vehicle.
- Routinely check security of hardware.
- Do not use automatic "brush-style" car washes.

Contents Illustrations may vary upon application

Grille

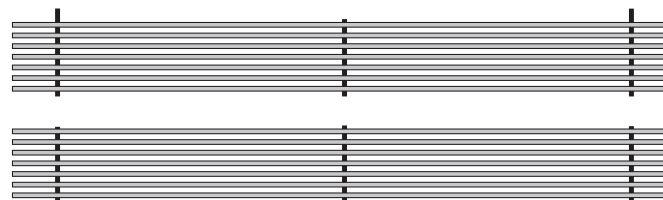

8 - 1/8" x 1/2" Pop Rivets

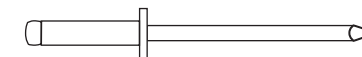

Tools Required

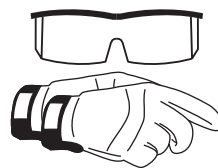

Safety Glasses
and Gloves

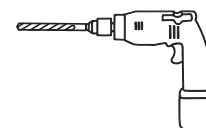

Drill with
1/8" Drill Bit

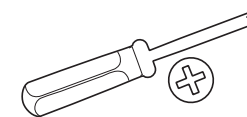

Phillips
Screwdriver



Die Grinder

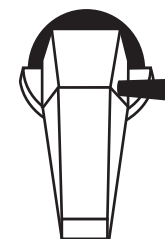

Angle Grinder



Rivet Gun

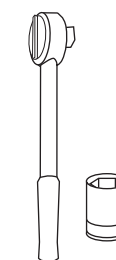

Ratchet with
1/4" Socket

Shipping Note

Sometimes the billet products get bent in the shipping process. You may need to hand bend them to attain the desired shape.



Installation Steps

Illustrations may vary upon application

Open the hood and remove all four (4) screws on the corner of each turn signal with a Phillips head screwdriver. Save them for later installation.

Pull each turn signal forward and twist off light bulbs from the light bezel.

Using a 1/4" socket, remove the bolt in the center of the grille shell's mesh. This one is no longer needed for later installation.

1

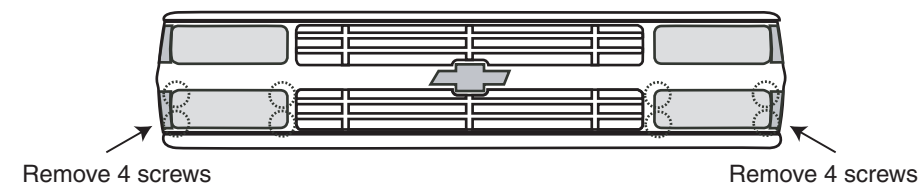

Look inside the opening where the turn signal was. Located on the bottom of the grille shell, you will see the plastic clips that hold the bottom of the grille shell to the vehicle. Pull upward 1/4" on the clip located closest to the end and pull the grille shell forward no more than 1/2". Working towards the center, continue to unsnap the rest of the clips.

2

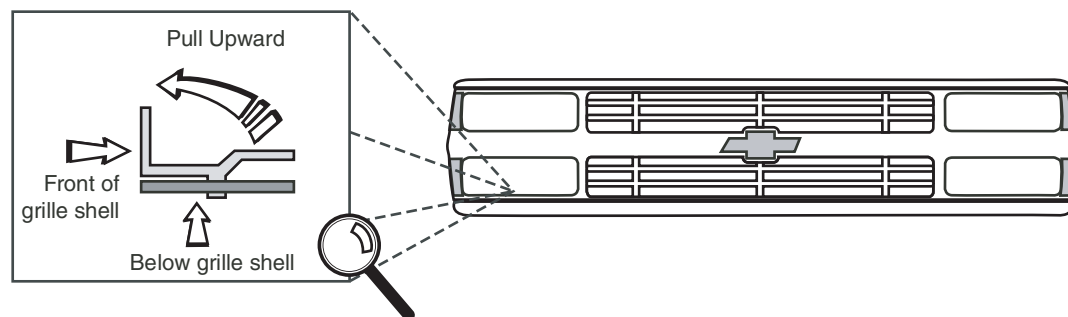

Using a die grinder, cut out the stock insert. Notch the top section where the vertical bars connect with the grille shell as indicated below.

3

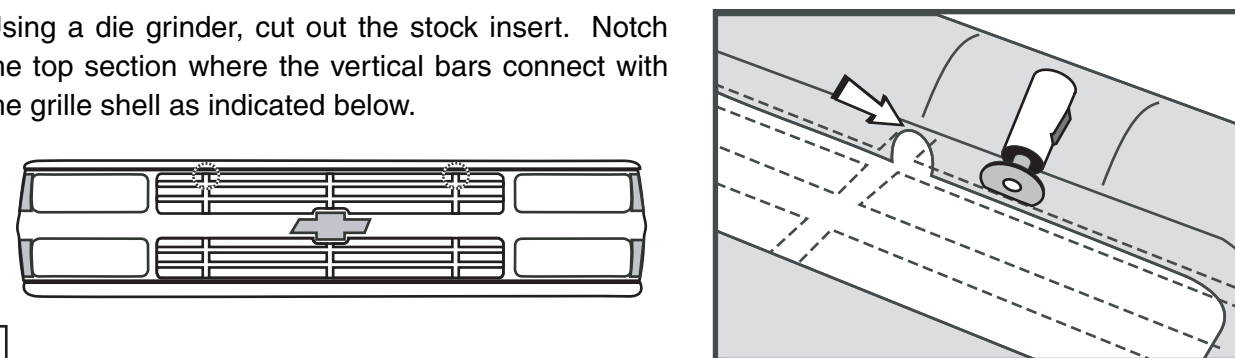

Using an angle grinder or file, smooth out the cuts from the die grinder. You may want to paint the areas that were just sanded for a nice clean look.

4

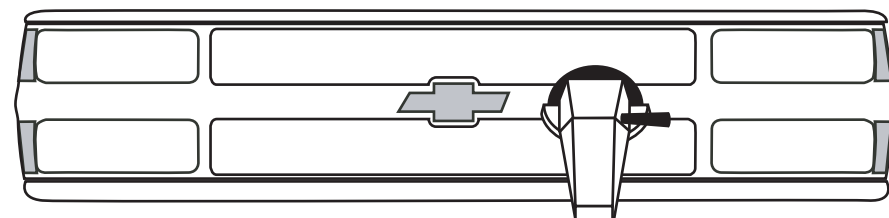

Drill eight (8) 1/8" holes through the plastic stock grille shell in the locations indicated below. Line up the holes with the dowels. Caution: Be careful not to scratch the grille shell.

Top

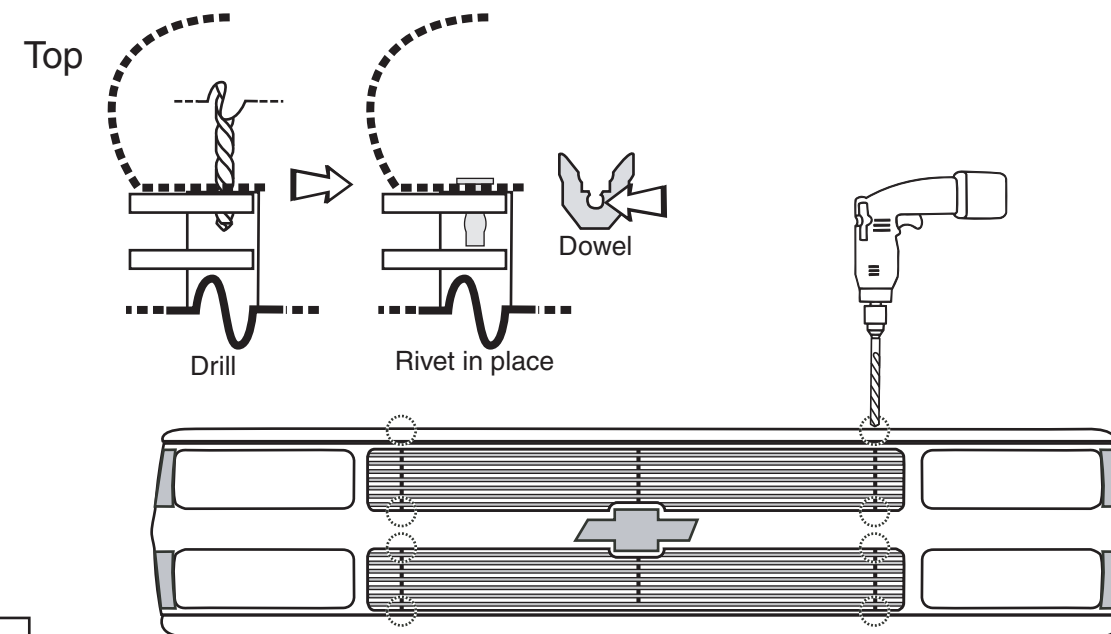

5

Using the 8 pop rivets included, rivet the grille in the locations you drilled in step 5.

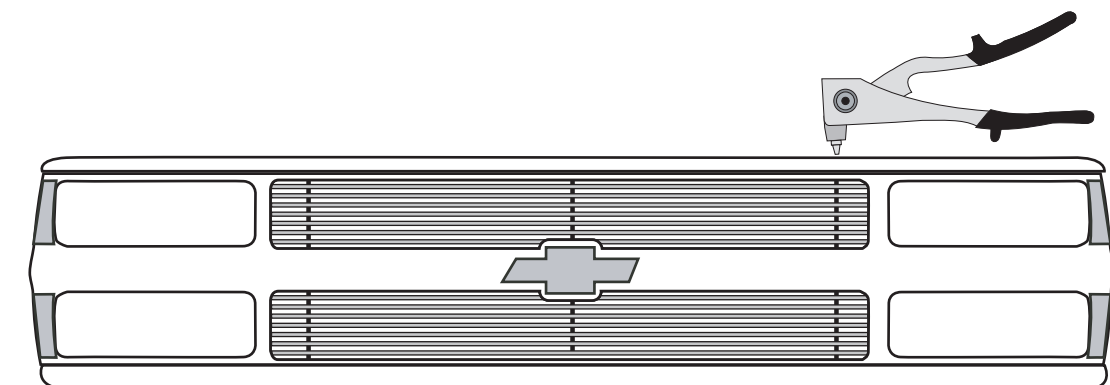

6

Reinstallation

Reinstall the stock shell with your new Billet Grille. Clip the grille shell back on the vehicle, reinstall the 1/4" screws along the top, and reinstall the turn signals. Make sure everything clears and close the hood. Enjoy your award-winning product that you have just installed!

7