



Original Bar Grille

For proper installation and best possible fit, please read all instructions **BEFORE** you begin.
For technical assistance or to obtain missing parts, please call Customer Relations at 1-800-328-5863.

Important Safety Information



CAUTION
PRECAUCIÓN
ATTENTION

To avoid risk of personal injury or property damage:

- Wear safety glasses and gloves while installing billet inserts.
- Use caution when working with any power tools.
- Check clearance on vehicle.
- Make sure that the billet inserts are secured in place and clears all moving parts of the vehicle.
- Routinely check security of hardware.
- Do not use automatic “brush-style” car washes.

Contents Illustrations may vary upon application

Billet Grille

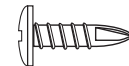
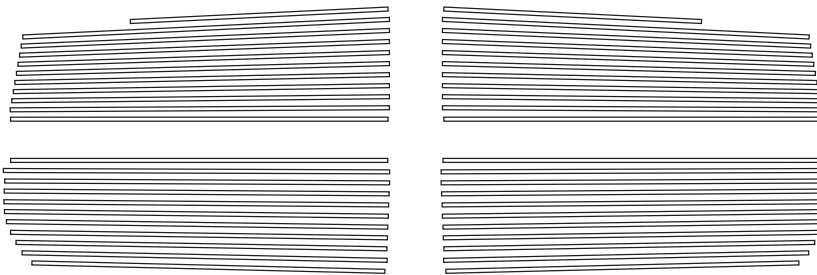

2 - 6 x 3/8" (T1)
Pan Head Tek Screws

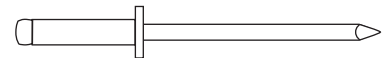

16 - 1/8" x 1/2" (R2) Pop Rivets

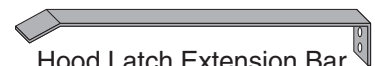

Hood Latch Extension Bar

Tools Required

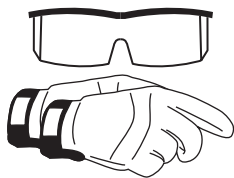

Safety Glasses
and Gloves

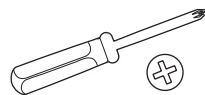

Phillips
Screwdriver

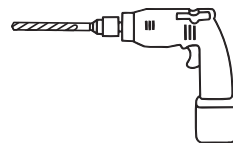

Drill with
1/8" Drill Bit



Rivet Gun

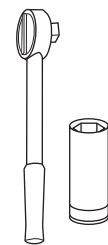

Ratchet with
8mm Deep Socket

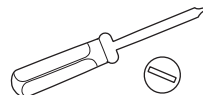

Flat Head
Screwdriver

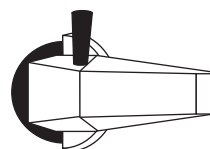

Angle Grinder

Shipping Note

Sometimes the billet products get bent in the shipping process. You may need to hand bend them to attain the desired shape.

Installation Steps Illustrations may vary upon application

Open the hood and using an 8mm socket, remove the six (6) 8mm nuts on top and the six (6) 8mm bolts on bottom. Once the nuts and bolts are removed, pull the grille shell towards you to remove it from the hood.

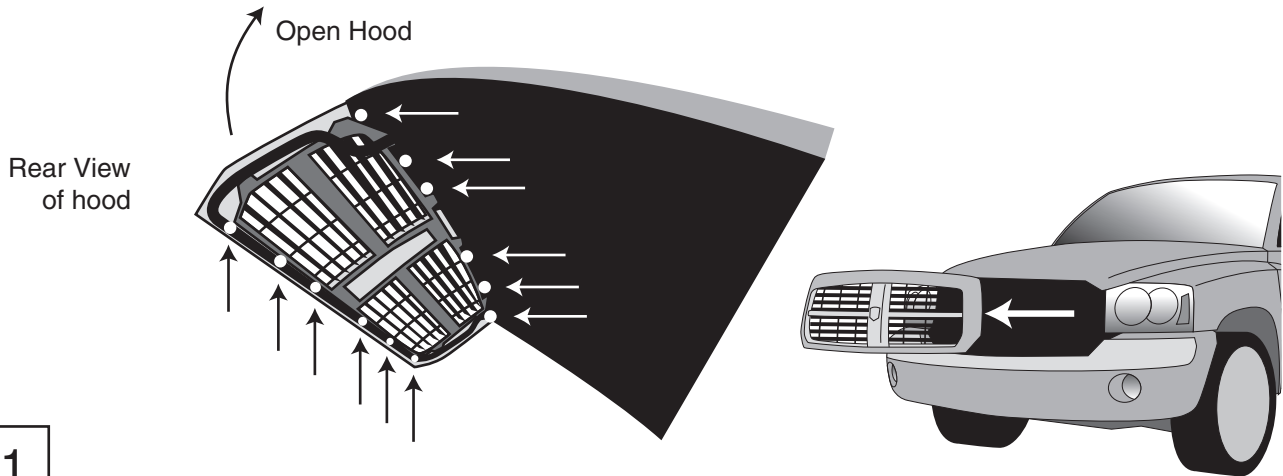

Place the grille face down on a flat, non-abrasive surface, blanket, or towel. To remove the black inner mesh, use a flat head screwdriver to pry apart the 24 tabs that hold it to the outer chrome grille shell.

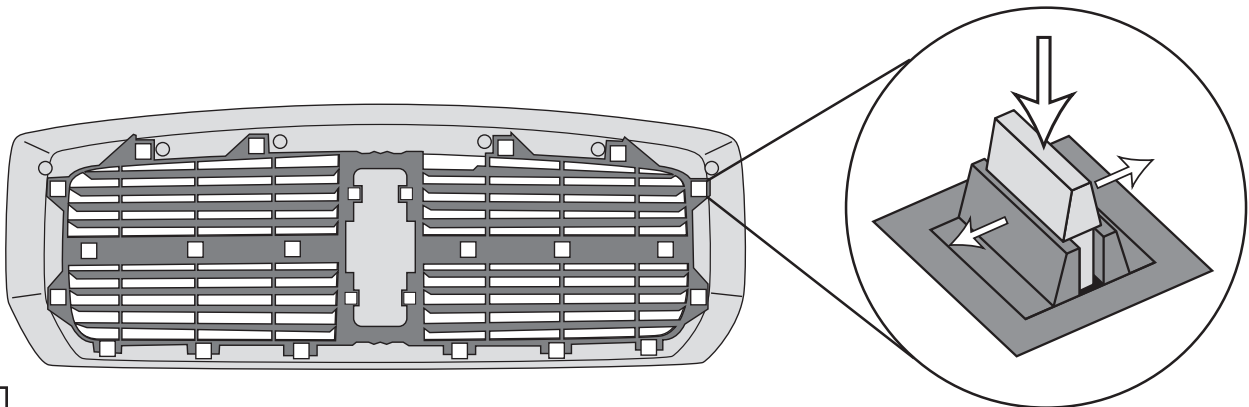

Using an Angle Grinder or Sander, grind down the following 12 tabs that hold the black mesh.

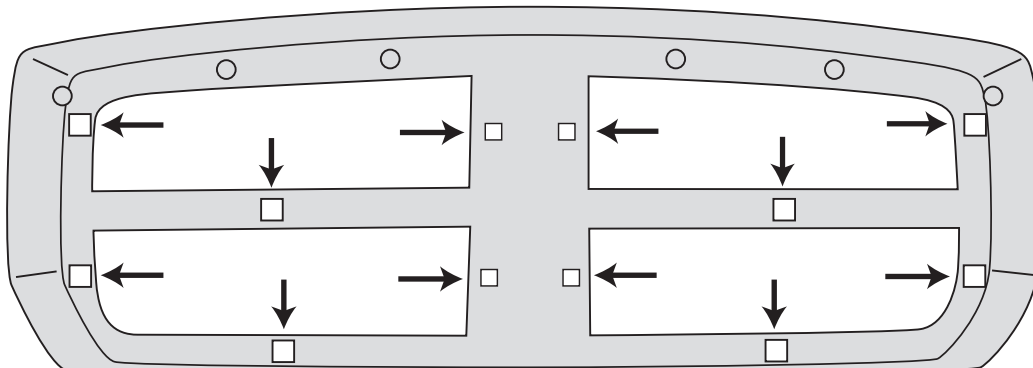

Insert the Billet Grille from the back of the grille shell. Using a 1/8" drill bit, carefully drill through the mounting tabs and grille shell.

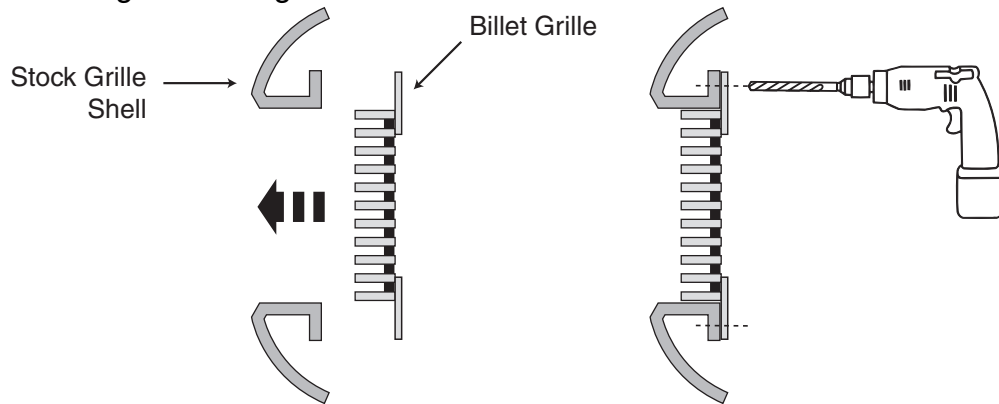

4

Using a rivet gun and the included rivets, attach the Billet Grille to the grille shell.

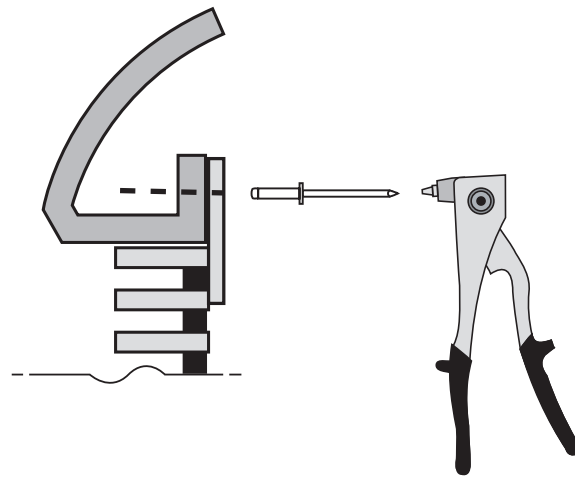

5

Return to the front of the vehicle and locate the hood release latch. Using the holes on the latch extension bar as a guide, drill two 1/8" holes through the tip of the hood release latch.

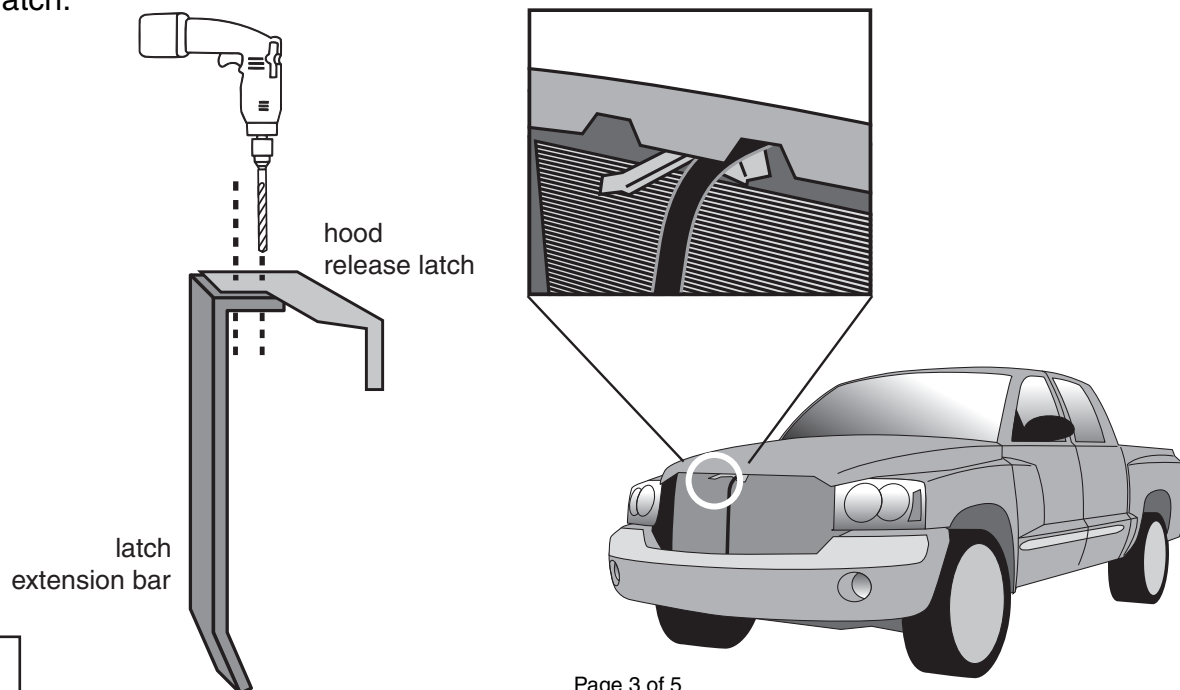

6

Using a Phillips head screwdriver, attach the latch extension bar to the hood release latch with the two 6x3/8" Tek Screws provided. This extension will allow you to open your hood once the Billet Grille is installed.

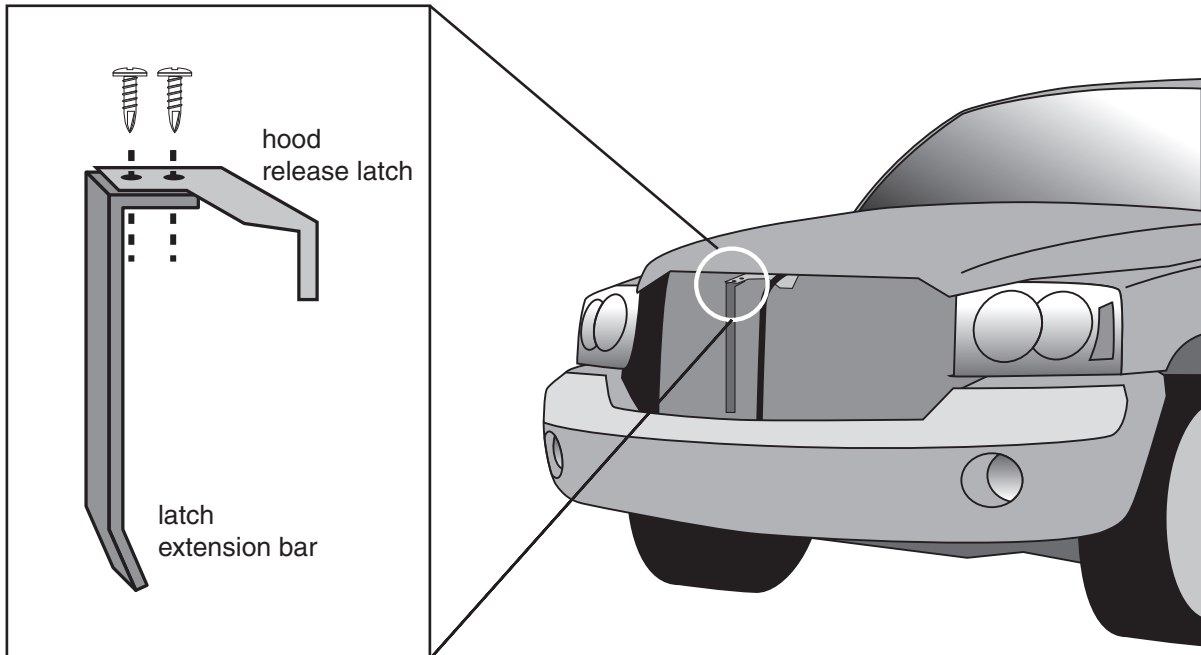

7

Using the six (6) 8mm nuts and six (6) 8mm bolts, reattach the grille shell to the truck. Make sure everything is secure and close the hood. Enjoy your award-winning product that you have just installed!

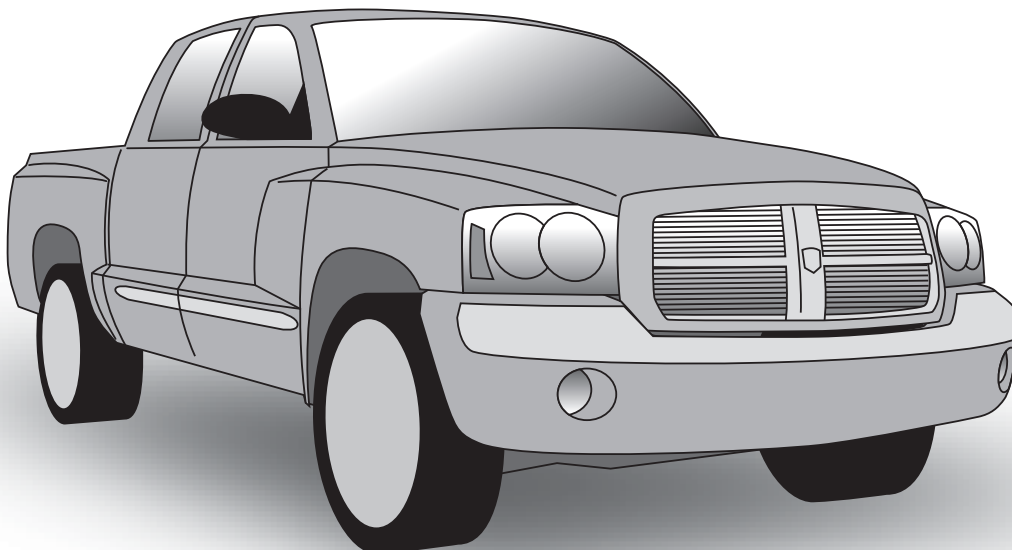

8

Care and Cleaning

To keep your billet inserts looking their best, we recommend using only mild soap and water and a soft cotton cloth to wash and dry it. Use of rough cleaning agents or cloths may scratch or dull your billet inserts.

Should your billet inserts become scratched or dull, we recommend TRENZ® Metal Polish to bring back the mirror finish. There are three grades of TRENZ® Metal Polish (Coarse, Medium and Fine) that will help you keep your billet inserts looking brand new. Select the TRENZ® Metal Polishes best for your needs:

1. Course (Red) Polish – For severe scratches and pitted problems.
2. Medium (Green) Polish – For light scratches and dulling problems.
3. Fine (White) Polish – To bring back the mirror finish.

TRENZ® Metal Polish can be used on all metal products, including aluminum, stainless steel, brass and copper. If you have additional questions or concerns on the maintenance of your Lund® billet inserts, please call us at 800-328-5863. You may also use high quality commercially available polish recommended for aluminum accessories.

Congratulations!

You have purchased one of many quality Lund® branded products offered by Lund International, Inc. We take the utmost pride in our products and want you to enjoy years of satisfaction from your investment. We have made every effort to ensure that your product is top quality in terms of fit, durability, finish and ease of installation.



Lund International, Lund Accessories Division
775 Tipton Industrial Drive, Building 2, Suite F
Lawrenceville, GA 30045

Phone 800-328-5863 • Fax 800-782-5448 • Visit us at lundinternational.com

© 2005 Lund International, Inc. All rights reserved.
Lund® and the Lund® logo are trademarks of Lund International, Inc.

