



Original Bar Grille

For proper installation and best possible fit, please read all instructions **BEFORE** you begin.
For technical assistance or to obtain missing parts, please call Customer Relations at 1-800-328-5863.

Important Safety Information



CAUTION
PRECAUCIÓN
ATTENTION

To avoid risk of personal injury or property damage:

- Wear safety glasses and gloves while installing billet inserts.
- Use caution when working with any power tools.
- Check clearance on vehicle.
- Make sure that the billet inserts are secured in place and clears all moving parts of the vehicle.
- Routinely check security of hardware.
- Do not use automatic “brush-style” car washes.

Contents

Illustrations may vary upon application

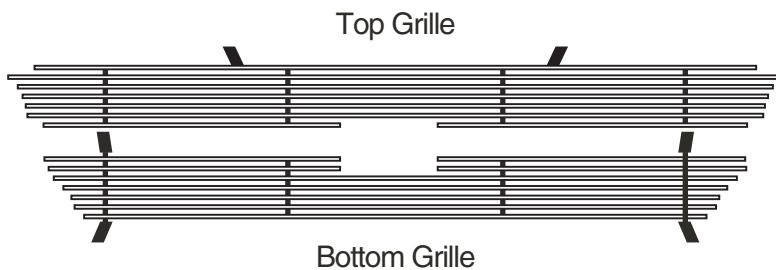

8 - 1/8" x 1/2" Pop Rivets

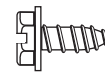
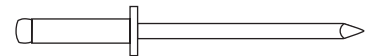

2 - 8x3/8" (H3)
Hex Head Screws

Tools Required



Safety Glasses
and Gloves

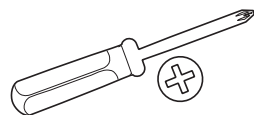

Phillips
Screwdriver

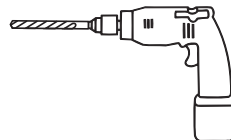

Drill with
1/8" Drill Bit

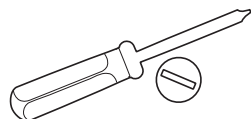

Flat Head
Screwdriver

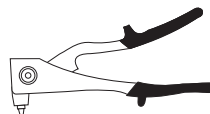

Rivet Gun



Die Grinder
or Hacksaw

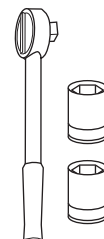

Ratchet with
10mm and 3/8"
Sockets

Shipping Note

Sometimes the billet products get bent in the shipping process. You may need to hand bend them to attain the desired shape.

Installation Steps Illustrations may vary upon application

Open the hood and remove all seven (7) of the stock black plastic rivets on the radiator cover by prying up the center of the rivet with a flat head screwdriver. Keep the rivets to reinstall the grille shell later.

After removing the plastic rivets, pop the black radiator cover off the top of the grille shell and set aside to replace after grille is installed.

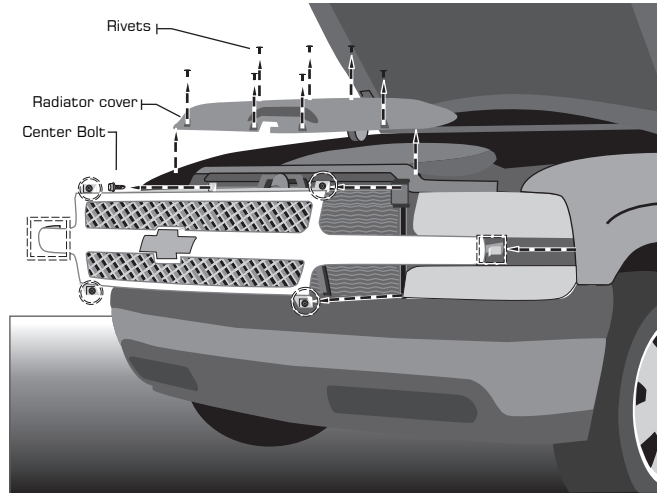
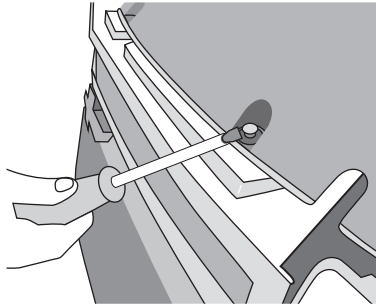

1

Using a Phillips screwdriver, turn each plastic screw a quarter turn to loosen the center of the grille shell.

To remove the side clips, pull the center bar out just enough to slide a flat head screwdriver between the grille shell and the fender. Be extremely careful in between the grille and the fender. Touching the side clip, very carefully turn the handle of the screwdriver to pull out the side clip.

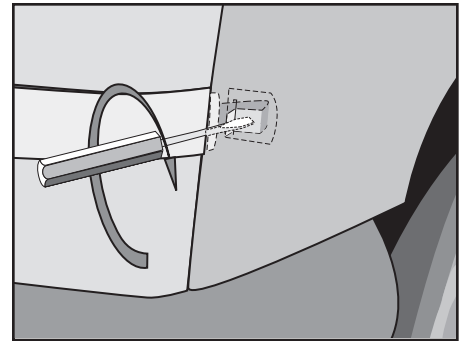

2

Using a 10mm socket, remove the center bolt on the top of the stock grille shell.

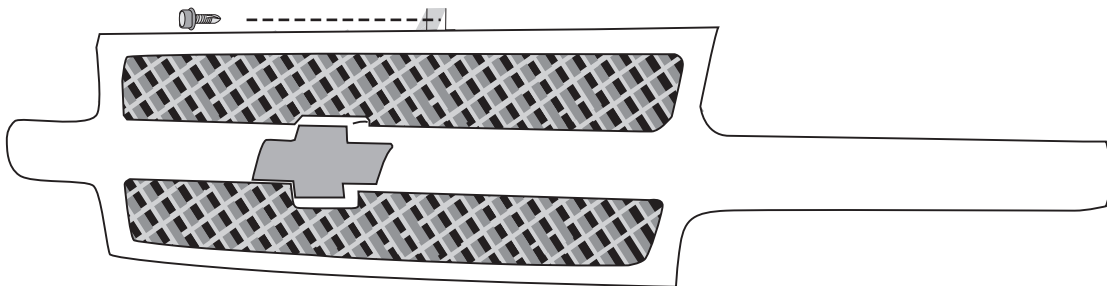

3

Pull the stock grille shell towards you to remove from the vehicle. Place the stock grille shell face down. Make sure to work on a flat, non-abrasive surface, blanket, or towel to prevent scratching.

4

The inner webbing is attached to the grille shell by 22 plastic welds.

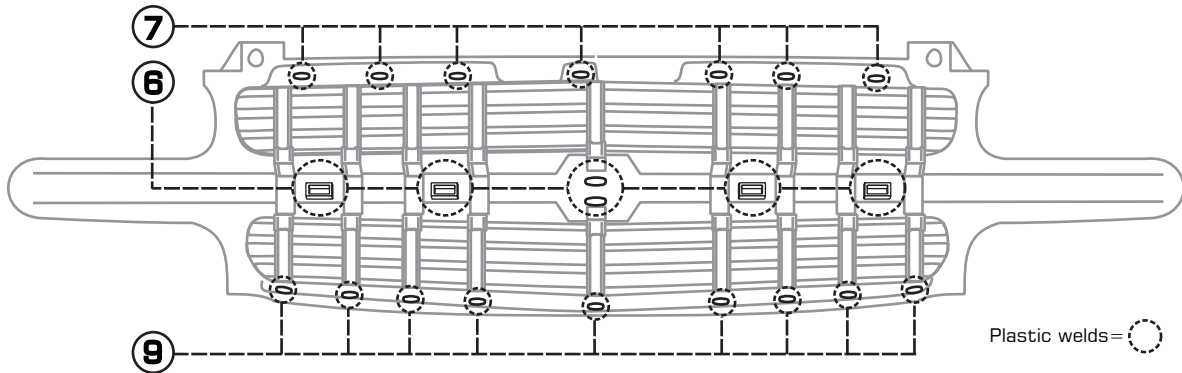

Remove all plastic welds with a die grinder. **Caution - Be careful not to grind through the grille shell!**

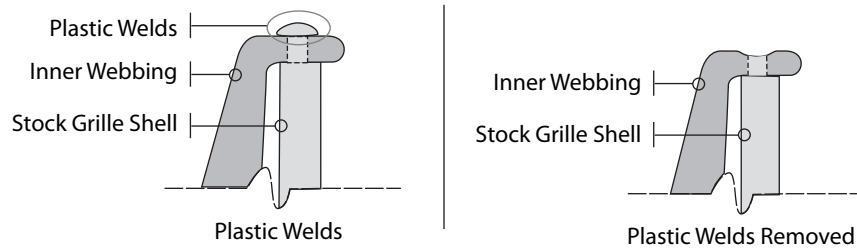

Once all plastic welds are removed, loosen the inner webbing and remove it from the stock grille shell.

Note: Some grille shells have a steel support bar. The steel bar must be bent back slightly in order to remove the inner webbing. Be careful not to break the bar.

5

Identifying the Grills

The top grille has 2 mounting tabs and 4 dowels.

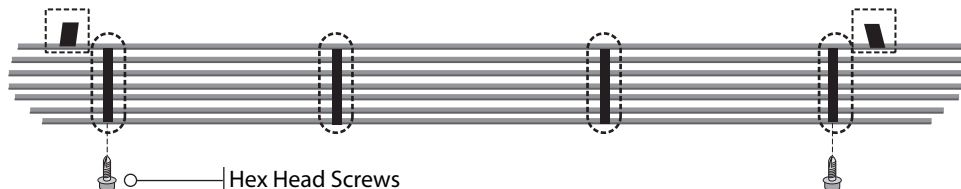

The bottom grille has 4 mounting tabs and 4 dowels.

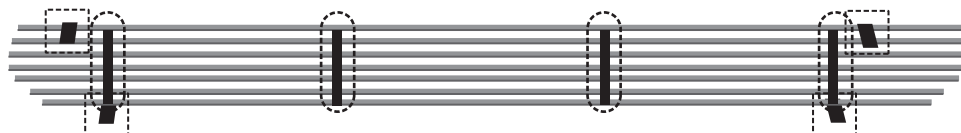

6

Bottom Grille Installation

For this step, you will need: Drill with 1/8" Drill Bit, Rivet Gun, 4 - 1/8" x 1/2" Pop Rivets, and the Bottom Billet Grille

Insert the bottom Billet Grille from the front into the bottom stock grille shell opening. Make sure that the grille is centered and fits tightly against the grille shell. Be careful not to scratch the grille shell as you are putting it in. Once the grille is in place, locate the tabs on each end. Drill through the tabs and grille shell using a 1/8" drill bit to make a rivet hole. Rivet the tab and shell together. Drill and rivet all remaining tabs.

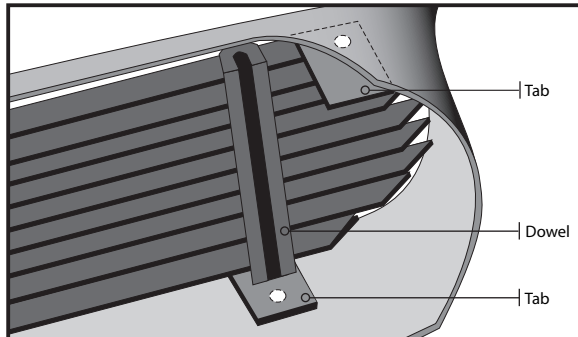

Drill and Rivet = 

7

Top Grille Installation

For this step, you will need: Drill with 1/8" Drill Bit, Rivet Gun, 2 - 1/8" x 1/2" Pop Rivets, 2 - 3/8" Hex Head Screws, flat head screwdriver, and the Top Billet Grille.

Insert the top Billet Grille from the front into the top stock grille shell opening. Drill and rivet the 2 top tabs. Once the 2 top tabs are secure, drill pilot holes for the Hex Head Screws. Note: Before you drill the pilot hole, make sure the grille fits tightly against the grille shell. Line up the outer dowels with the pilot holes and screw the Hex Head Screws into the dowels.

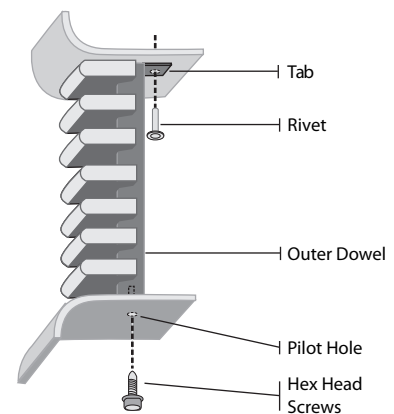

8

Reinstall the stock shell with your new Billet Grille onto the vehicle. Place the grille shell back on the front of the vehicle and line up the side clips and clip back in place. Tighten the 4 plastic screws. Screw the center bolt back into place. Put the radiator cover back in place and pop in the 7 stock black plastic rivets. Make sure everything is secure and close the hood. Enjoy your award-winning product that you have just installed!

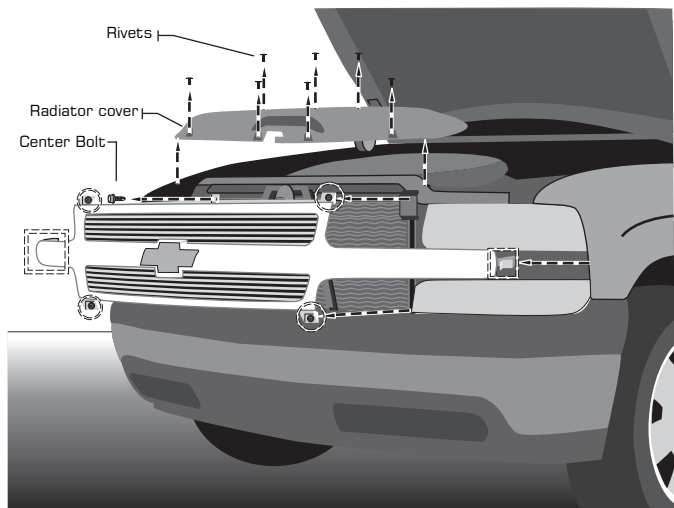

9

Care and Cleaning

To keep your billet inserts looking their best, we recommend using only mild soap and water and a soft cotton cloth to wash and dry it. Use of rough cleaning agents or cloths may scratch or dull your billet inserts.

Should your billet inserts become scratched or dull, we recommend TRENZ® Metal Polish to bring back the mirror finish. There are three grades of TRENZ® Metal Polish (Coarse, Medium and Fine) that will help you keep your billet inserts looking brand new. Select the TRENZ® Metal Polishes best for your needs:

1. Course (Red) Polish – For severe scratches and pitted problems.
2. Medium (Green) Polish – For light scratches and dulling problems.
3. Fine (White) Polish – To bring back the mirror finish.

TRENZ® Metal Polish can be used on all metal products, including aluminum, stainless steel, brass and copper. If you have additional questions or concerns on the maintenance of your Lund® billet inserts, please call us at 800-328-5863. You may also use high quality commercially available polish recommended for aluminum accessories.

Congratulations!

You have purchased one of many quality Lund® branded products offered by Lund International, Inc. We take the utmost pride in our products and want you to enjoy years of satisfaction from your investment. We have made every effort to ensure that your product is top quality in terms of fit, durability, finish and ease of installation.



Lund International, Lund Accessories Division
775 Tipton Industrial Drive, Building 2, Suite F
Lawrenceville, GA 30045

Phone 800-328-5863 • Fax 800-782-5448 • Visit us at lundinternational.com

© 2005 Lund International, Inc. All rights reserved.
Lund® and the Lund® logo are trademarks of Lund International, Inc.

