

Care and Cleaning

To keep your billet grille looking their best, we recommend using only mild soap and water and a soft cotton cloth to wash and dry it. Use of rough cleaning agents or cloths may scratch or dull your billet grille.

Should your billet grille become scratched or dull, we recommend TRENZ® Metal Polish to bring back the mirror finish. There are three grades of TRENZ® Metal Polish (Coarse, Medium and Fine) that will help you keep your billet grille looking brand new. Select the TRENZ® Metal Polishes best for your needs:

1. Course (Red) Polish – For severe scratches and pitted problems.
2. Medium (Green) Polish – For light scratches and dulling problems.
3. Fine (White) Polish – To bring back the mirror finish.

TRENZ® Metal Polish can be used on all metal products, including aluminum, stainless steel, brass and copper. If you have additional questions or concerns on the maintenance of your Lund® billet grille, please call us at 800-328-5863. You may also use high quality commercially available polish recommended for aluminum accessories.

Congratulations!

You have purchased one of many quality Lund® branded products offered by Lund International, Inc. We take the utmost pride in our products and want you to enjoy years of satisfaction from your investment. We have made every effort to ensure that your product is top quality in terms of fit, durability, finish and ease of installation.



Lund International, Lund Accessories Division
775 Tipton Industrial Drive, Building 2, Suite F
Lawrenceville, GA 30045

Phone 800-328-5863 • Fax 800-782-5448 • Visit us at lundinternational.com

© 2005 Lund International, Inc. All rights reserved.
Lund® and the Lund® logo are trademarks of Lund International, Inc.

Installation Instructions

Part Number 84127

I-sheet Rev. A2



Original Bar Grille

For proper installation and best possible fit, please read all instructions **BEFORE** you begin.
For technical assistance or to obtain missing parts, please call Customer Relations at 1-800-328-5863.

Important Safety Information



CAUTION
PRECAUCIÓN
ATTENTION

To avoid risk of personal injury or property damage:

- Wear safety glasses and gloves while installing billet inserts.
- Use caution when working with any power tools.
- Check clearance on vehicle.
- Make sure that the billet inserts are secured in place and clears all moving parts of the vehicle.
- Routinely check security of hardware.
- Do not use automatic “brush-style” car washes.

Contents

Illustrations may vary upon application

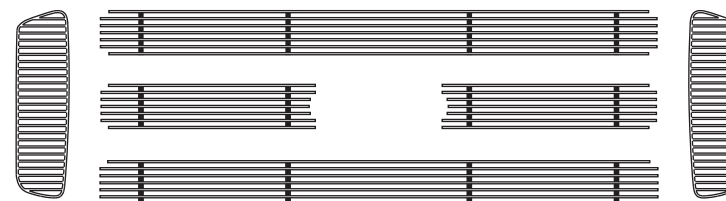

Billet Grille



10 - Hair Pin Clips



10 - Slider Tabs

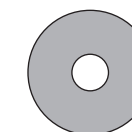

4 - 1/4 x 1”
(W19) Washers



4 - 10/32 (N6)
Kep Nuts

Tools Required



Safety Glasses
and Gloves

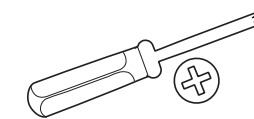

Phillips
Screwdriver

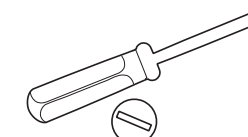

Flat Head
Screwdriver

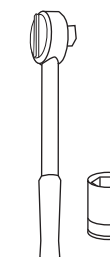

Ratchet with
10mm Socket

Shipping Note

Sometimes the billet products get bent in the shipping process. You may need to hand bend them to attain the desired shape.

Installation Steps Illustrations may vary upon application

Remove the four (4) screws with a Phillips screwdriver and save them for reinstallation.

Behind the grille shell, there are two steel clips holding the bottom of the grille shell. Using a flat head screwdriver, pull upward on the bottom of the clip and pull the grille shell forward.

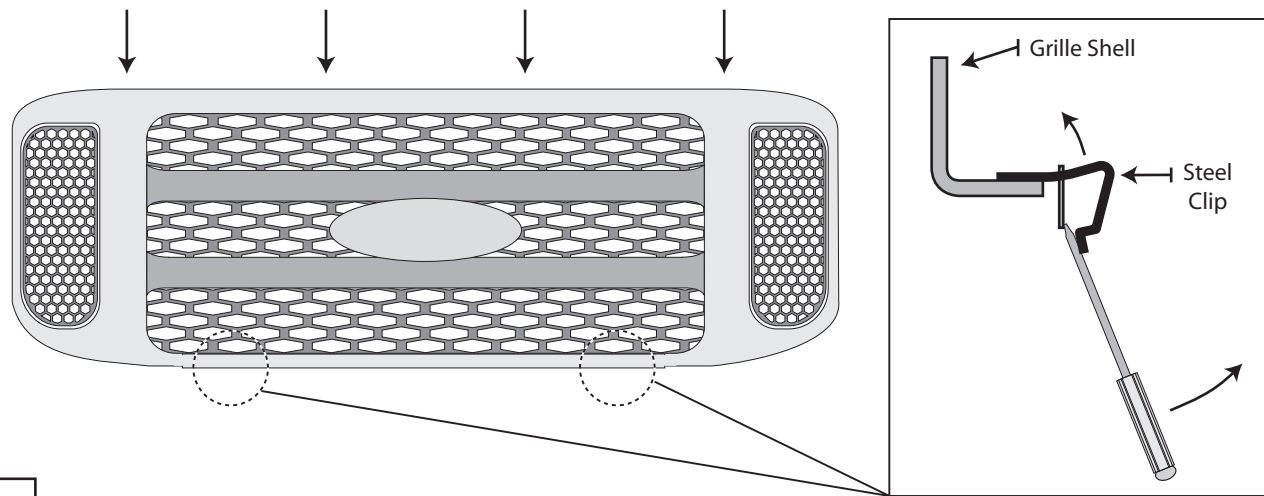

1

Starting with the center grille inserts, slide one grille insert at a time from the front of the grille shell. The mounting tabs should go through the grille shell mesh. Using the slider tabs and the hair pin clips, slide one slider tab from the top into each of the mounting tab holes.

Main Center Grilles

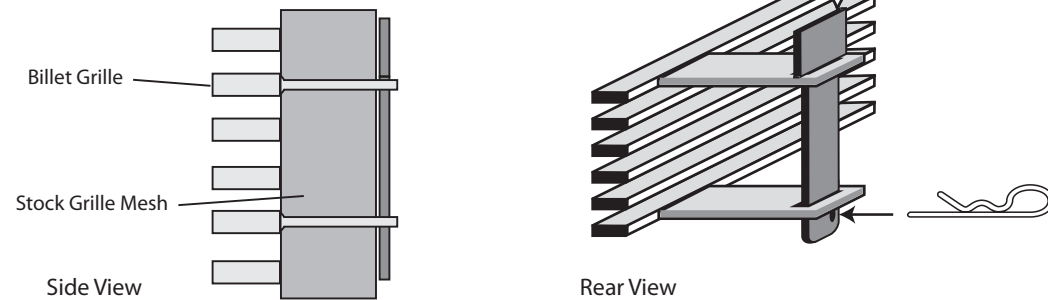

2

Locate the side Billet Grille inserts. Insert them from the front of the grille shell. Secure side grilles by using fender washers and Kep nuts provided.

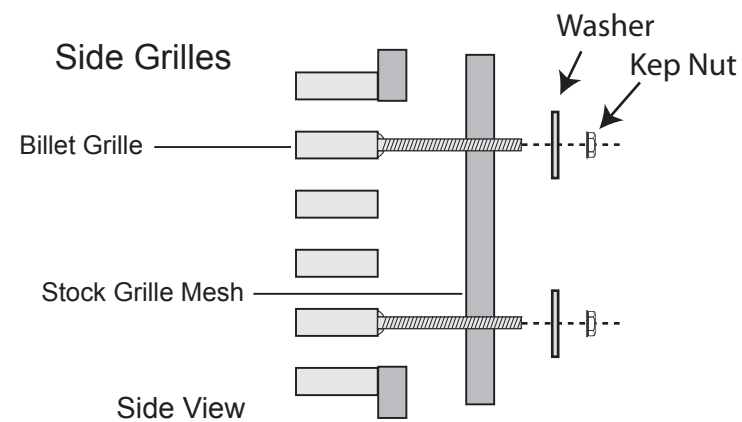

3

Clip the bottom of the grille shell back on the truck and secure the top of the grille using the four (4) screws that were removed in the first step. Make sure everything is secured and close the hood. Enjoy your award-winning grille that you have just installed!

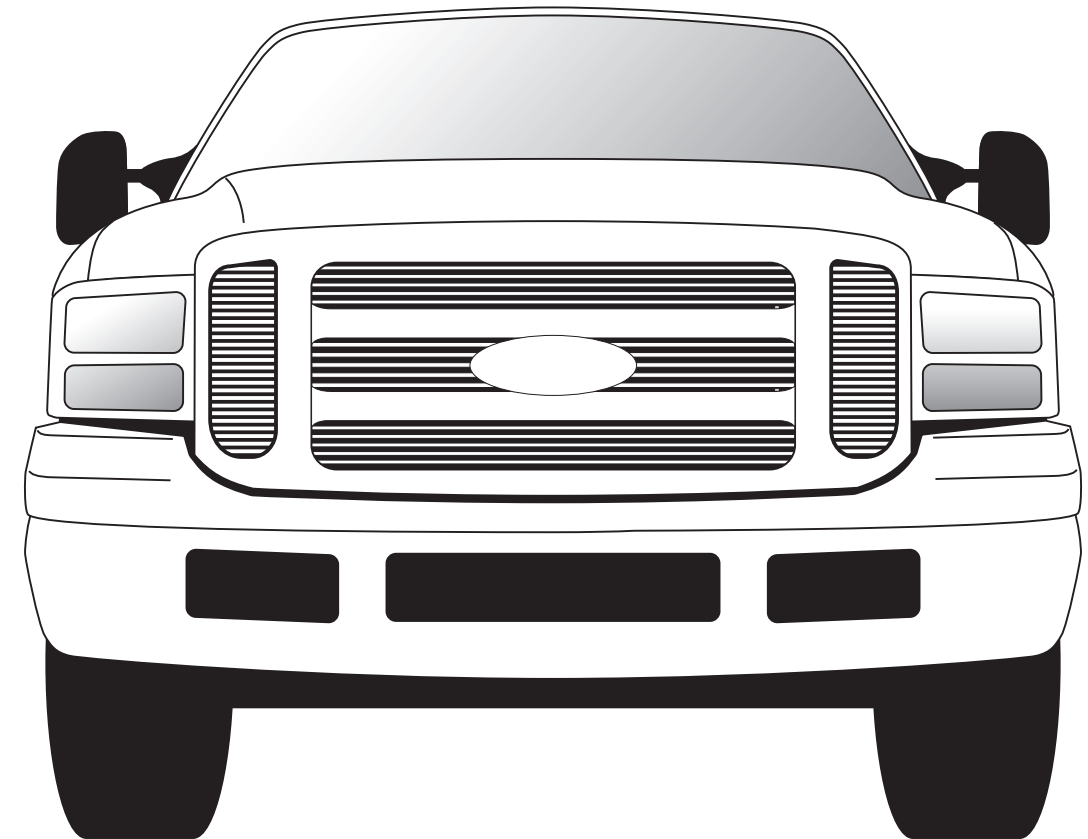

4