



Original Bar Grille

For proper installation and best possible fit, please read all instructions **BEFORE** you begin.
For technical assistance or to obtain missing parts, please call Customer Relations at 1-800-328-5863.

Important Safety Information



CAUTION
PRECAUCIÓN
ATTENTION

To avoid risk of personal injury or property damage:

- Wear safety glasses and gloves while installing billet inserts.
- Use caution when working with any power tools.
- Check clearance on vehicle.
- Make sure that the billet inserts are secured in place and clears all moving parts of the vehicle.
- Routinely check security of hardware.
- Do not use automatic “brush-style” car washes.

Contents Illustrations may vary upon application

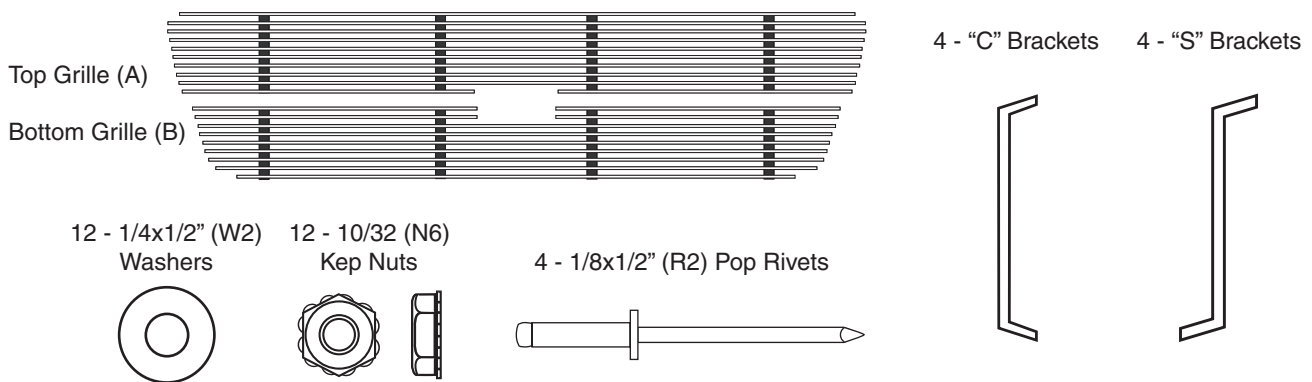

Tools Required

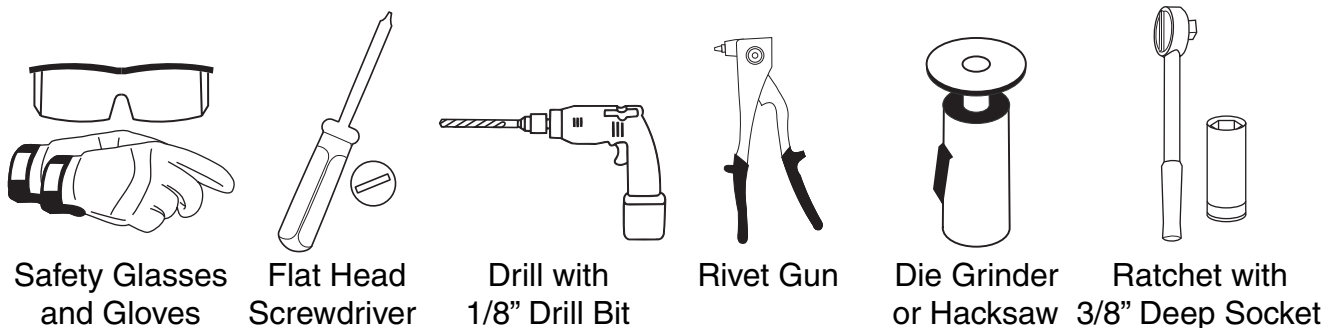

Shipping Note

Sometimes the billet products get bent in the shipping process. You may need to hand bend them to attain the desired shape.

Installation Steps Illustrations may vary upon application

Pop open the hood and remove all seven (7) of the stock black plastic rivets across the radiator cover by prying up the center of the rivet with a flat head screwdriver. Keep the rivets to use for reinstalling the radiator cover. Once the plastic rivets are removed, pop the black radiator cover off the top of the grille shell and set aside to reinstall after the Billet Grille is installed.

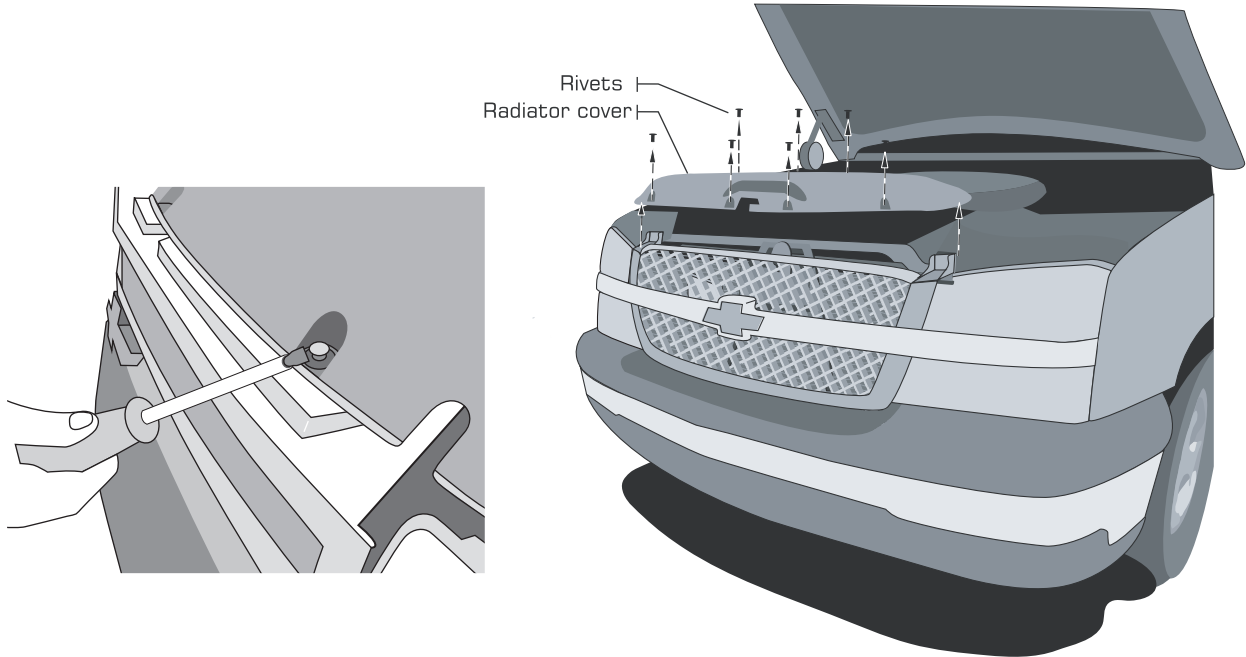

1

To remove the headlight bezels you must pull out the metal pin located at the top of the headlight. Remove the pin by pulling the short side upward and slide out toward the center of the truck. Turn the headlight bezel forward and pull upward. Gently remove each light bulb out of the bezel. Set the bezels aside to reinstall after the Billet Grille is installed.

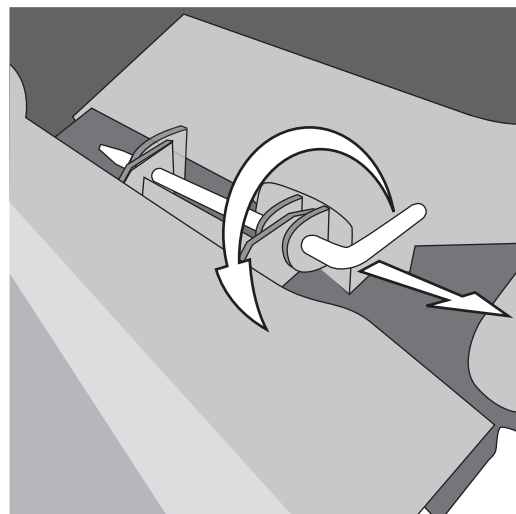

2

After lights are removed, use a flat head screwdriver to gently pry away the mounting clips that are attached to the mounting brackets on the truck (4 holding the center and one on each side). To get to the side clips, pull the center bar out just enough to slide a flat head screwdriver between the grille shell and the fender. Be extremely careful in between the grille shell and the fender. Touching the side clip, very carefully turn the handle of the screwdriver to pull out the side clip.

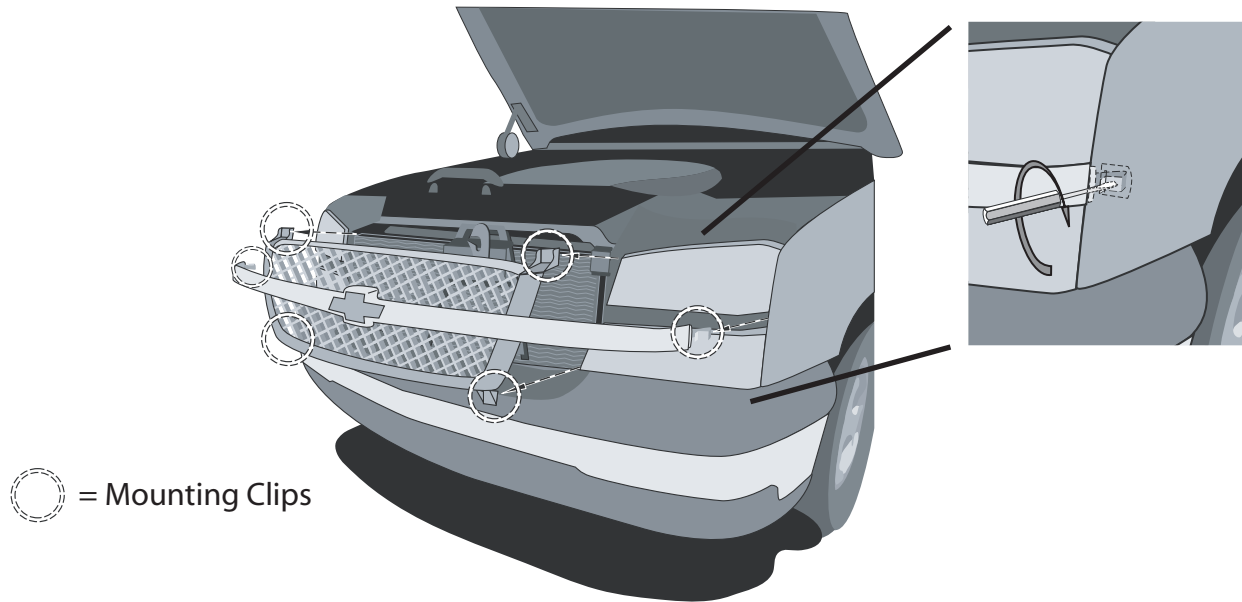

Pull the stock grille shell towards you to remove from the vehicle. Then place the stock grille shell face down. Work on a flat non-abrasive surface such as a blanket or towel to prevent scratching.

3

Installation Options

BOLT OVER vs. CUT OUT

This Billet Grille has 2 installation options:

- **BOLT OVER** (mounts over existing stock grille with no cutting)
- **CUT OUT** (requires cutting of stock grille shell)

Please read the following instructions carefully to choose which option you will want to use.

BOLT-OVER Installation Steps Illustrations may vary upon application

Take the Billet Grille out of the shrink wrapping. The top grille has ten (10) bars and six (6) mounting studs extending from the back of the Billet Grille. The bottom grille has nine (9) bars and six (6) studs extending from the back of the Billet Grille.

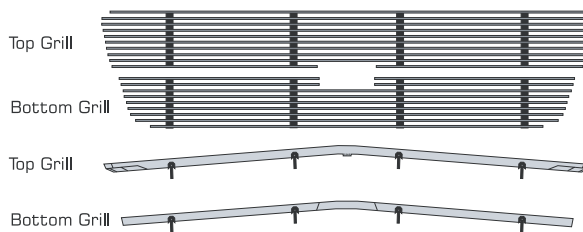

4a

Bottom Grille Installation

For this step, you will need: bottom Billet Grille, 6 Washers, 6 10/32 Fine Thread Kep Nut, 4 "C" brackets, and a Ratchet with 3/8" Deep Socket.

Insert the Billet Grille from the front into the bottom of the stock grille shell opening. Make sure that the Billet Grille is centered and that the mounting studs go between the holes of the mesh opening.

After the Billet Grille is in place, slide the "C" bracket over the mounting studs. Make sure that the grille is first centered within the shell. Then, using the washers and 10/32 Kep nuts provided, secure the Billet Grille and "C" brackets in place. **Caution: do not over tighten Kep nuts!**

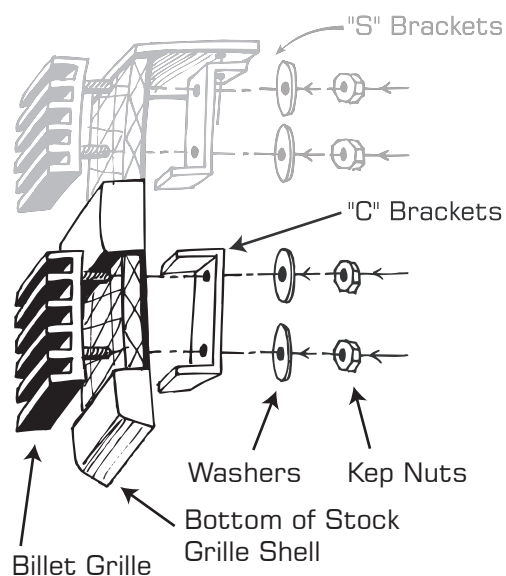

4b

Top Grille Installation

For this step you will need: Top Billet Grille, 6 Washers, 6 10/32 Fine Thread Kep Nuts, 4 "S" brackets, Ratchet with 3/8" Deep Socket.

Insert the Billet Grille from the front into the top of the stock grille shell opening. Make sure that the Billet Grille is centered and that the mounting studs go between the holes of the mesh opening.

After the billet Grille is in place, slide the "S" brackets over the mounting studs. (The top of the "S" brackets faces towards the Billet Grille) Make sure that the grille is first centered within the shell. Then, using the washers and 10/32 Kep nuts provided, secure the Billet Grille and "S" brackets in place. **Caution: do not over tighten the Kep nuts!** Once the Billet Grille is secure, then hand manipulate the top tab of the "S" brackets to best fit the top bracket of the stock grille.

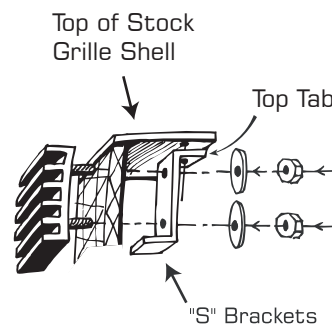

Skip to Step 5 on page 6.

4c

CUT OUT Installation Steps

Illustrations may vary upon application

Take the Billet Grille out of the shrink wrapping. The top grille has ten (10) bars and six (6) mounting studs extending from the back of the Billet Grille. The bottom grille has nine (9) bars and six (6) studs extending from the back of the Billet Grille.

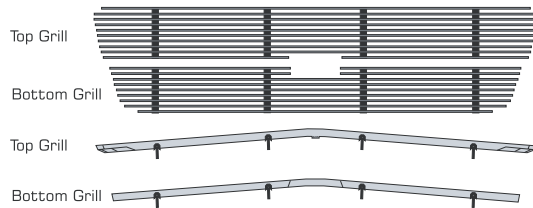

4a

Removing Stock Mesh

For this step, you will need a Die Grinder or Hacksaw.

To remove the stock mesh, you need to cut all the mesh/webbing EXCEPT for the 1/4" shell lip that encases the webbing. **Note: This lip serves as a support to keep the new Billet Grilles from coming through the shell.**

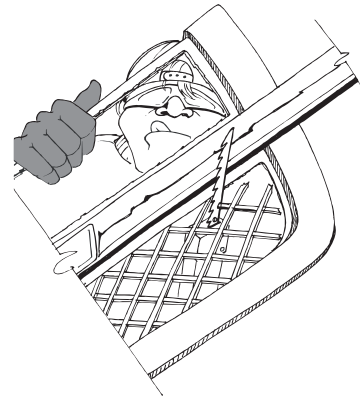

4b

Bottom Grille Installation

For this step, you will need: bottom Billet Grille, 6 Washers, 6 10/32 Fine Thread Kep Nuts, 4 "C" brackets, and a Ratchet with 3/8" Deep Socket.

Insert the Billet Grille from the front into the bottom opening of the stock grille shell. Make sure that the Billet Grille is centered and that the mounting studs go between the holes of the mesh opening.

After the Billet Grille is in place, slide the "C" bracket over the mounting studs. Make sure that the grille is first centered within the shell. Then, using the washers and 10/32 Kep Nuts provided, secure the Billet Grille and "C" brackets in place. **Caution: do not over tighten Kep Nuts!**

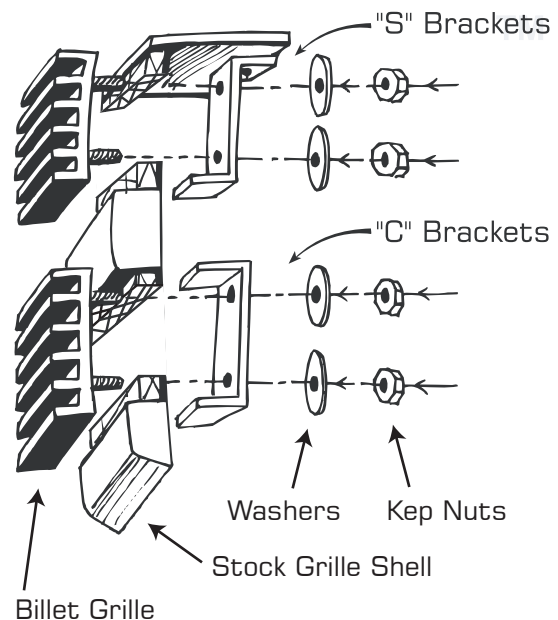

4c

Top Grille Installation

For this step you will need: Top Billet Grille, 6 Washers, 6 10x32 Fine Thread Kep Nuts, 4 "S" brackets, Ratchet with 3/8" Deep Socket.

Insert the Billet Grille from the front into the top opening of the stock grille shell. Make sure that the Billet Grille is centered and that the mounting studs go between the holes of the mesh opening.

After the Billet Grille is in place, slide the "S" brackets over the mounting studs. (The top of the "S" brackets faces towards the Billet Grille) Make sure that the grille is centered within the shell. Then, using the washers and 10x32 Kep nuts provided, secure the Billet Grille and "S" brackets in place. **Caution: do not over tighten the set screws!** Once the Billet Grille is secure, then hand manipulate the top tab of the "S" brackets to best fit the top bracket of the stock grille.

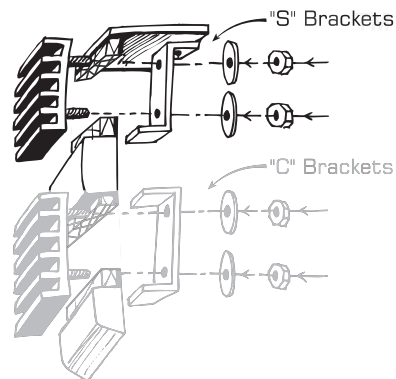

4d

Once the top grille is attached, using a 1/8" drill bit, drill a hole through each mounting tab and through the grille shell. Secure each tab to the grille shell using a Rivet Gun and the rivets provided.

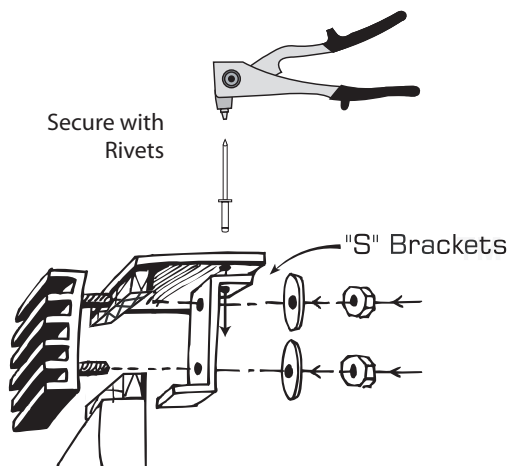
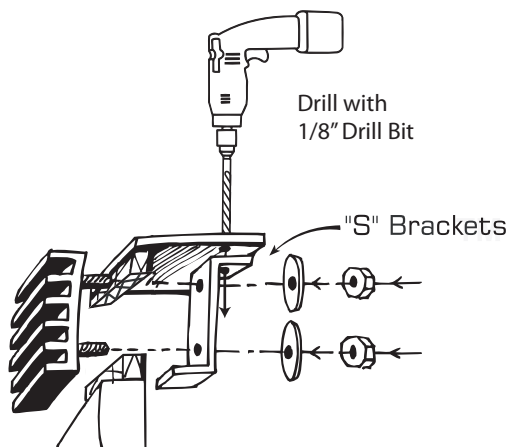

4e

To reinstall the stock shell with your new Billet Grille on to the vehicle, place the grille shell back on the front of the vehicle, line up the mounting clips, and clip back in place. Reinstall the headlight bezels with the stock pins. Put the radiator cover back in place and secure it by popping in the 7 stock plastic rivets you removed earlier.

Make sure everything is secure and close the hood. Enjoy your award-winning product that you have just installed!

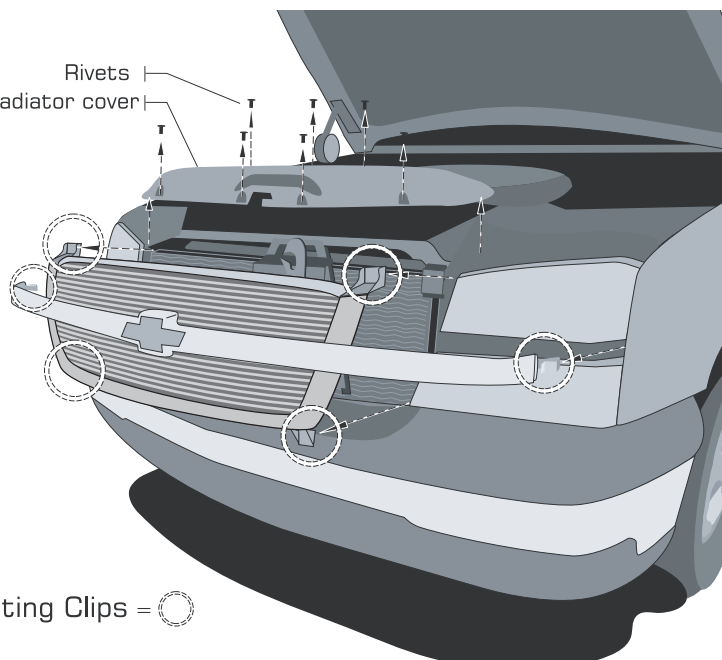

5

Care and Cleaning

To keep your billet inserts looking their best, we recommend using only mild soap and water and a soft cotton cloth to wash and dry it. Use of rough cleaning agents or cloths may scratch or dull your billet inserts.

Should your billet inserts become scratched or dull, we recommend TRENZ® Metal Polish to bring back the mirror finish. There are three grades of TRENZ® Metal Polish (Coarse, Medium and Fine) that will help you keep your billet inserts looking brand new. Select the TRENZ® Metal Polishes best for your needs:

1. Course (Red) Polish – For severe scratches and pitted problems.
2. Medium (Green) Polish – For light scratches and dulling problems.
3. Fine (White) Polish – To bring back the mirror finish.

TRENZ® Metal Polish can be used on all metal products, including aluminum, stainless steel, brass and copper. If you have additional questions or concerns on the maintenance of your Lund® billet inserts, please call us at 800-328-5863. You may also use high quality commercially available polish recommended for aluminum accessories.

Congratulations!

You have purchased one of many quality Lund® branded products offered by Lund International, Inc. We take the utmost pride in our products and want you to enjoy years of satisfaction from your investment. We have made every effort to ensure that your product is top quality in terms of fit, durability, finish and ease of installation.



Lund International, Lund Accessories Division
775 Tipton Industrial Drive, Building 2, Suite F
Lawrenceville, GA 30045

Phone 800-328-5863 • Fax 800-782-5448 • Visit us at lundinternational.com

© 2005 Lund International, Inc. All rights reserved.
Lund® and the Lund® logo are trademarks of Lund International, Inc.

