



Original Bar Grille

For proper installation and best possible fit, please read all instructions **BEFORE** you begin.
For technical assistance or to obtain missing parts, please call Customer Relations at 1-800-328-5863.

Important Safety Information



CAUTION
PRECAUCIÓN
ATTENTION

To avoid risk of personal injury or property damage:

- Wear safety glasses and gloves while installing billet inserts.
- Use caution when working with any power tools.
- Check clearance on vehicle.
- Make sure that the billet inserts are secured in place and clears all moving parts of the vehicle.
- Routinely check security of hardware.
- Do not use automatic “brush-style” car washes.

Contents

Illustrations may vary upon application

A

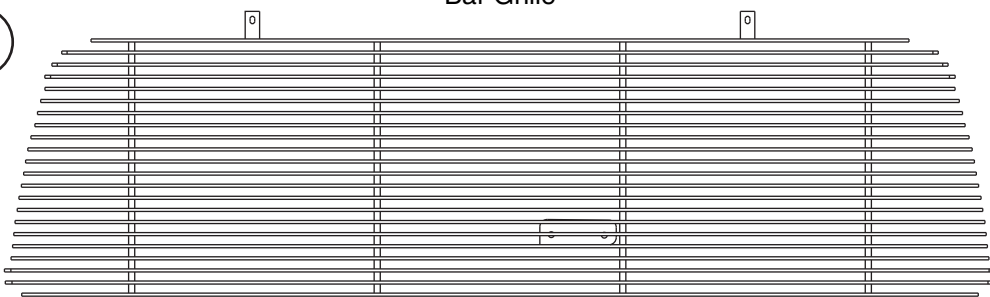

Bar Grille

B

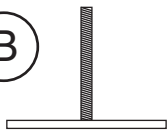

2 - Mounting Brackets

C



2 - #10 SAE Flat Washers

D



2 - 10/32 (N6) Kep Nuts

Tools Required

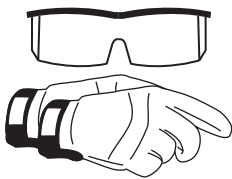

Safety Glasses
and Gloves

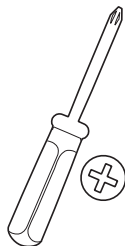

Phillips
Screwdriver

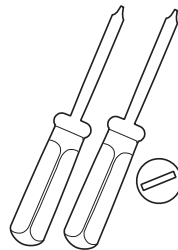

2 Flat Head
Screwdrivers

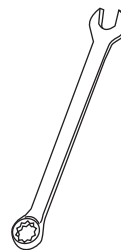

10mm Wrench



Die Grinder
or Hacksaw

Shipping Note

Sometimes the billet products get bent in the shipping process. You may need to hand bend them to attain the desired shape.

Installation Steps

Illustrations may vary upon application

Remove plastic insert on top of shell using a flat head screwdriver and remove mounting screws.

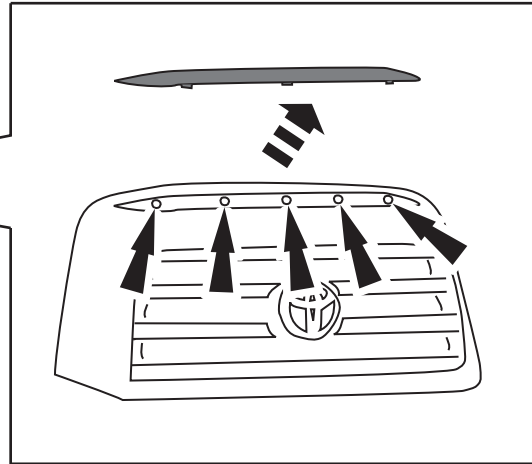
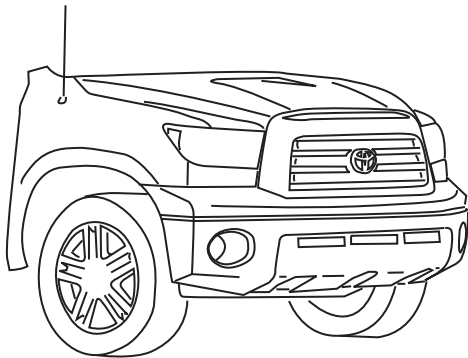

1

Pop the hood and remove grille shell by detaching hood latch rod and removing mounting hardware.

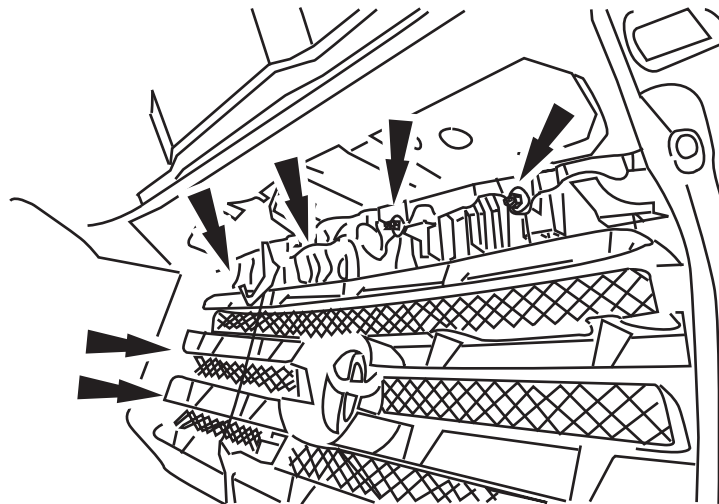

2

Remove black support bar from bottom of grille shell. Remove hood latch bracket from back of insert.

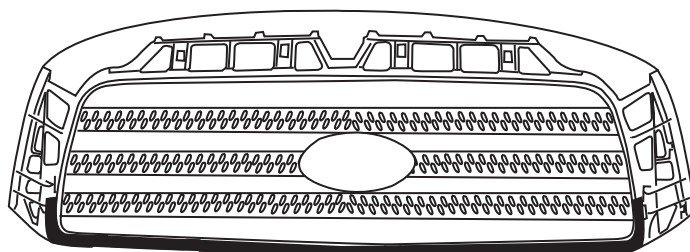

Black Support Bar

Hood Latch Bracket

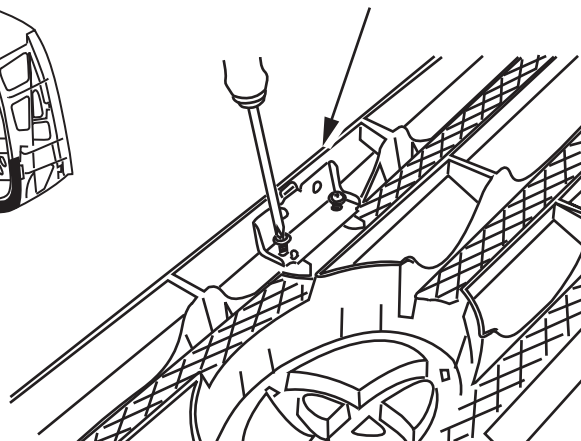

3

Installation Steps

Illustrations may vary upon application

Remove plastic insert from grille shell using one or two flat head screwdrivers as needed. It is easiest to start from one side and move your way across to the other side.

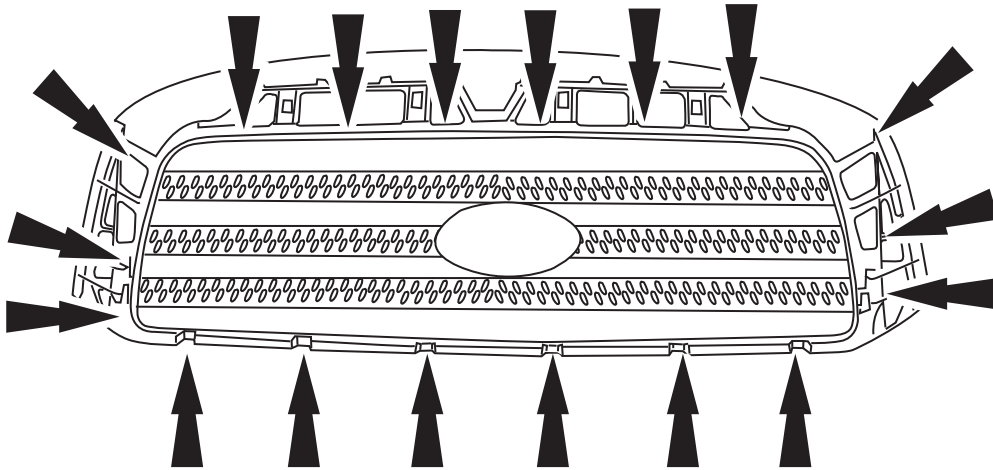

4

Using a die grinder cut the stock grille bars from the center of the insert.

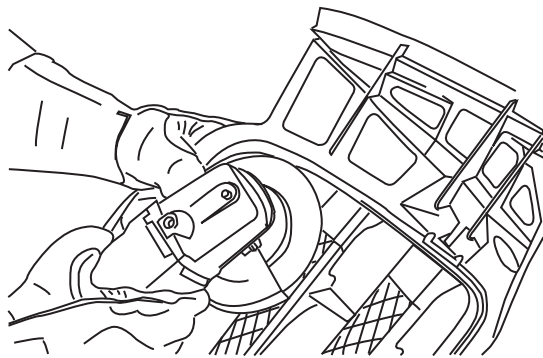

Before

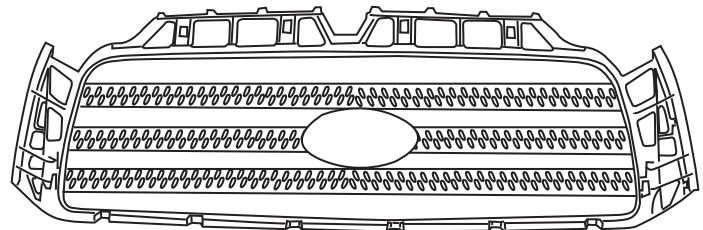

After

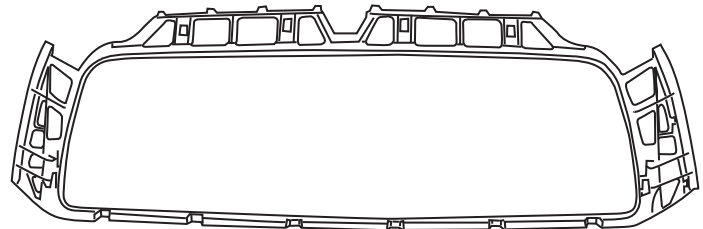

5

Snap insert back into place. Insert billet grille into grille shell from behind.

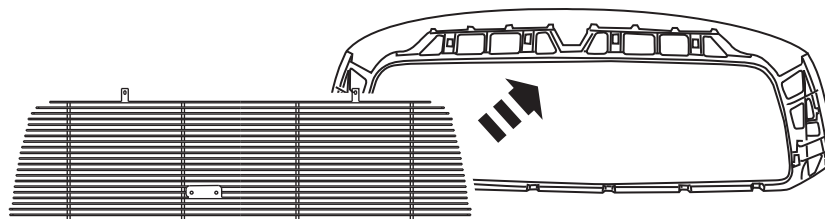

6

Installation Steps

Illustrations may vary upon application

With billet grille in place, install black support bar in original position over billet grille. Install hood latch bracket on indicated tab using stock hardware

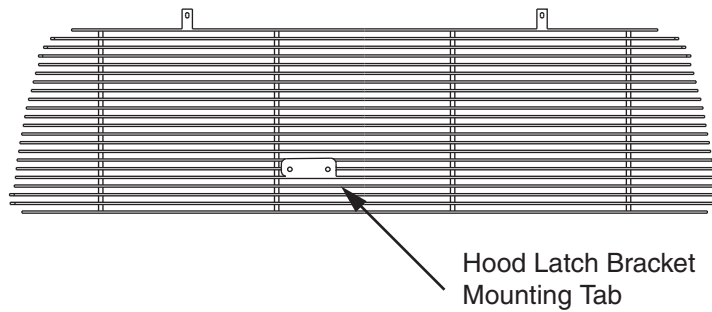

7

Hook mounting tabs under shell insert making sure that the stud protrudes through hole in billet grille tab. Use supplied hardware to finish mounting. **Caution: Do not overtighten kep nuts!**

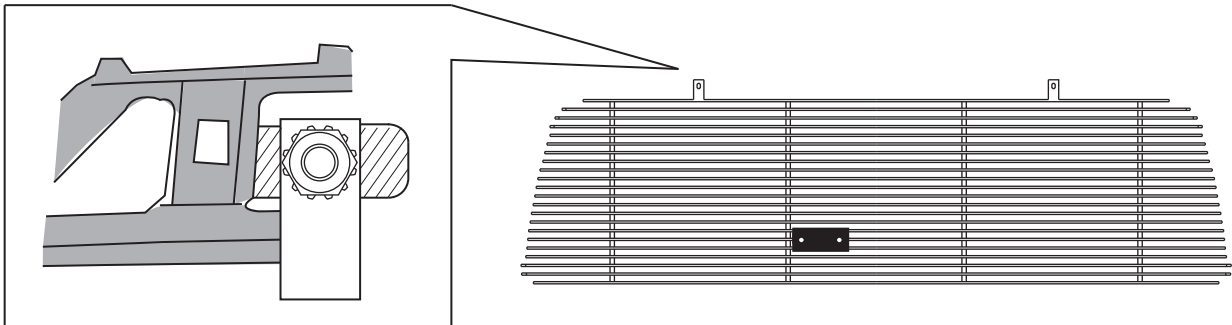

8

With billet grille installed, reinstall grille shell assembly on to vehicle in the reverse order that you removed it. Make sure to re-attach hood latch rod.

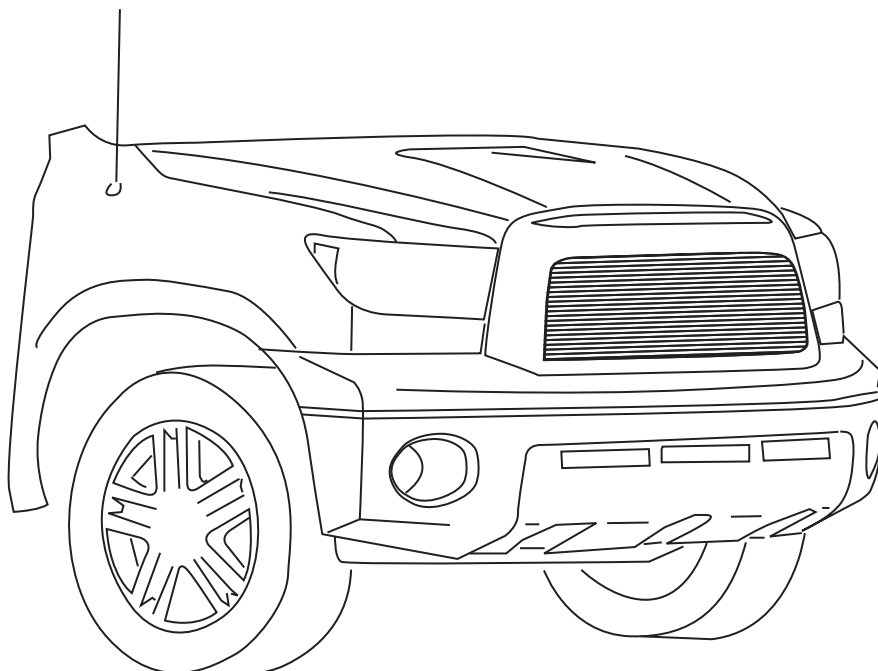

9

Care and Cleaning

To keep your LUND® Grille looking its best we recommend using only mild soap, water and soft cotton cloth to wash (and dry). Harsh cleaning agents or cloths may scratch or dull your grille.

Should your grille become scratched or dull you may use high quality, commercially-available, non-abrasive polish recommended specific for your grille's metal type.

If you have questions or concerns on the care of your LUND® grille, please call 800-328-5863.

Congratulations!

You have purchased one of many quality Lund® branded products offered by Lund International, Inc. We take the utmost pride in our products and want you to enjoy years of satisfaction from your investment. We have made every effort to ensure that your product is top quality in terms of fit, durability, finish and ease of installation.



Lund International, Lund Accessories Division
300 Horizon Drive
Suwanee, GA 30024

Phone 800-328-5863 • Fax 800-782-5448 • Visit us at lundinternational.com

© 2005 Lund International, Inc. All rights reserved.
Lund® and the Lund® logo are trademarks of Lund International, Inc.





Calandre originale

Pour réaliser une installation parfaite avec un bon ajustement, lire la totalité des instructions AVANT d'entreprendre le travail. Pour assistance technique ou pièces manquantes, contacter notre département service-client à 1-800-328-5863.

Sécurité – Information importante



CAUTION
PRECAUCIÓN
ATTENTION

Pour éviter un risque de blessures ou dommages matériels :

- Portez des lunettes de sécurité et des gants pour insérer les barres.
- Faites attention lorsque vous utilisez des outils électriques.
- Tenir compte des distances de dégagement sur le véhicule.
- Assurez-vous que les barres sont bien fixées en place et ne nuisent à aucune pièce mobile du véhicule.
- Soumettez la sécurité de votre matériel à une inspection routinière.
- N'utilisez pas les lave-autos à brosses.

Contenu

Les détails des illustrations peuvent être différents, selon le véhicule

A

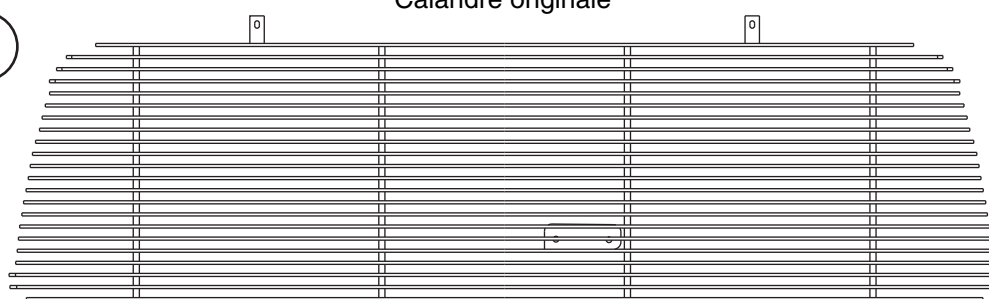

Calandre originale

B

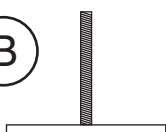

2 - Supports de Fixation

C



2 - Rondelles de #10 SAE

D



2 - Écrous à rondelle dentée 10/32

Outils nécessaires

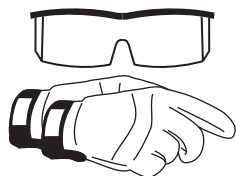

Lunettes de
sécurité et gants

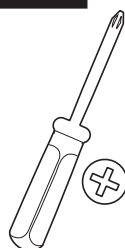

Tournevis à
tête cruciforme

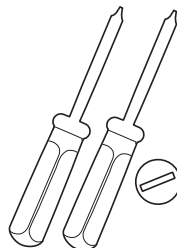

2 Tournevis à
lame plate (M)

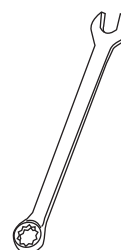

Clé de 10mm



Meule à
rectifier (F)

Note – Expédition

Il arrive parfois que les barres soient faussées lors du transport. Il se peut que vous ayez à les plier à la main pour obtenir la forme désirée.

Étapes de l'installation

Les détails des illustrations peuvent être différents, selon le véhicule

Retirez la garniture de plastique sur le dessus de l'habillage de calandre à l'aide d'un tournevis à lame plate et déposez les vis de montage.

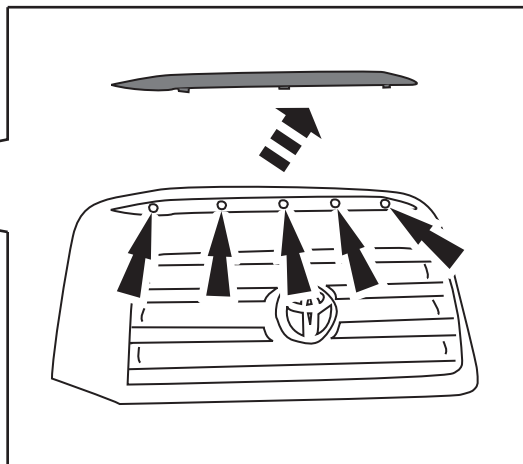
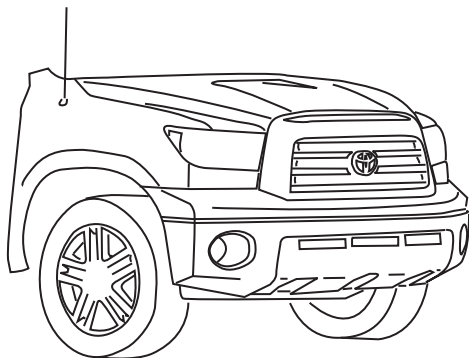

1

Ouvrez le capot et retirez l'habillage de calandre en démontant la tige de verrouillage du capot et en déposant la quincaillerie de montage.

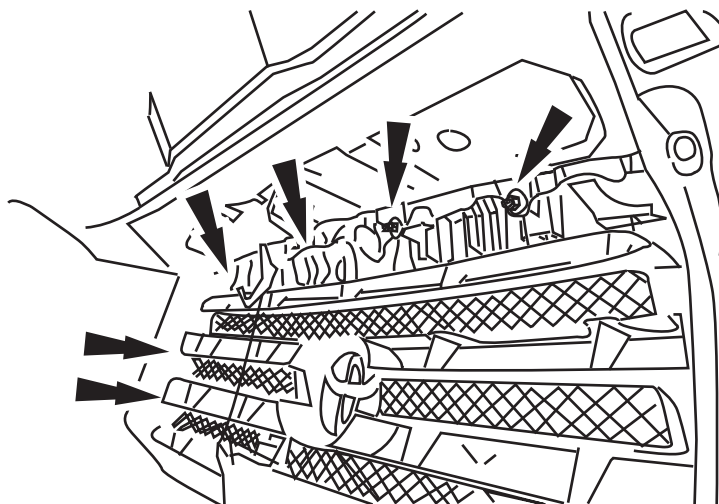

2

Démontez la barre portante noire se trouvant au bas de l'habillage de calandre. Retirez le support du dispositif de verrouillage du capot de l'arrière de la garniture.

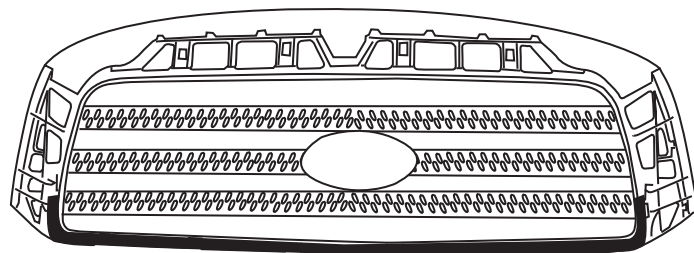

Barre Noire de Soutien

Parenthèse de Verrou de Capot

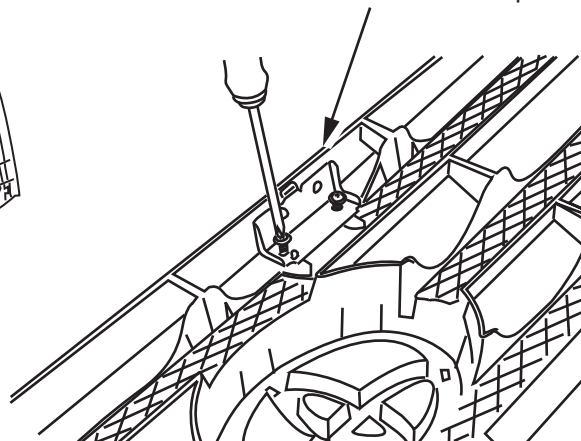

3

Étapes de l'installation

Les détails des illustrations peuvent être différents, selon le véhicule

Retirez la garniture de plastique de l'habillage de calandre en utilisant un ou deux tournevis à lame plate au besoin. Il est plus simple de commencer par un côté et de vous déplacer progressivement vers l'autre.

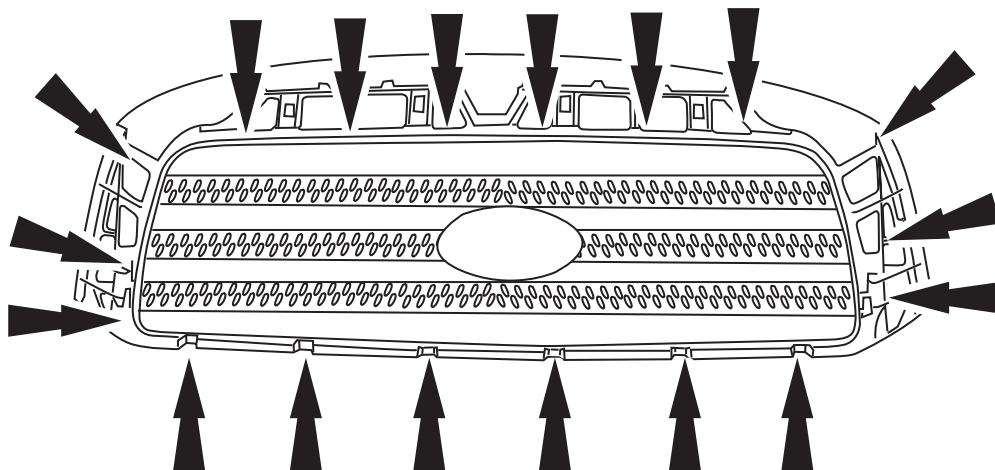

4

À l'aide d'une meule à rectifier les matrices, coupez les barres de l'habillage de calandre à partir du centre de la garniture.

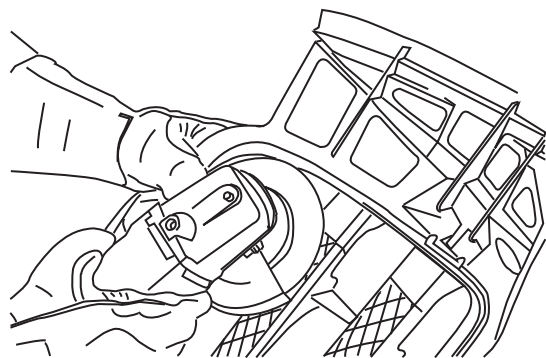

Avant La Coupure

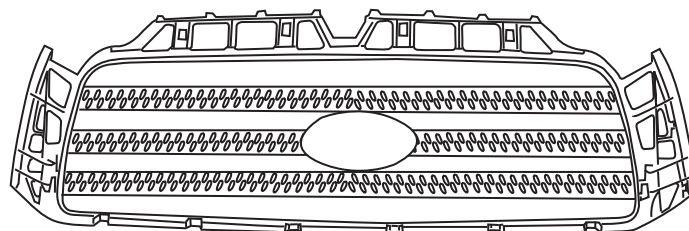

Après Coupure

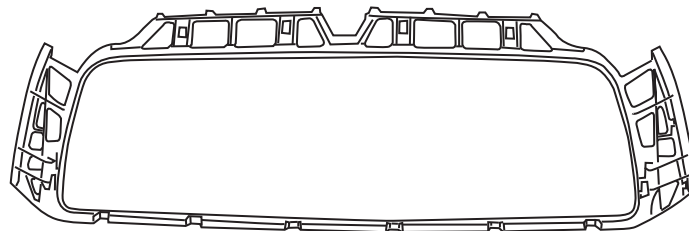

5

Réinstallez la garniture. Insérez la calandre à barres dans l'habillage de calandre à partir de l'arrière.

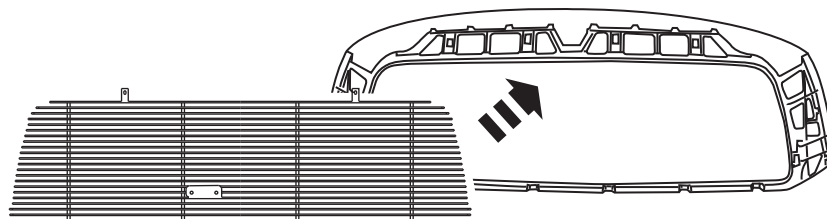

6

La calandre à barres étant en place, remettez la barre portante noire dans sa position initiale, au-dessus de la calandre à barres. Installez le support de verrouillage du capot sur la patte indiquée en utilisant la quincaillerie de série.

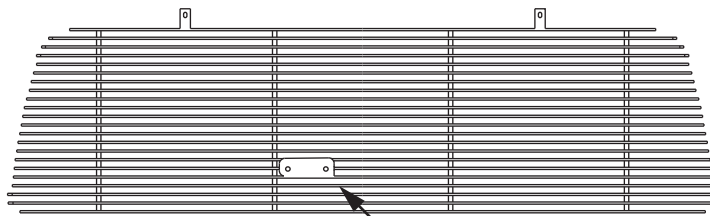

Étiquette de Support de
Parethèse de Verrou de Capot

7

Accrochez les pattes de montage sous la garniture de calandre en vous assurant que le goujon dépasse de l'ouverture présente dans la patte de la calandre à barres. Utilisez la quincaillerie fournie pour terminer le montage. **Attention: Ne serrez pas trop les écrous taquets!**

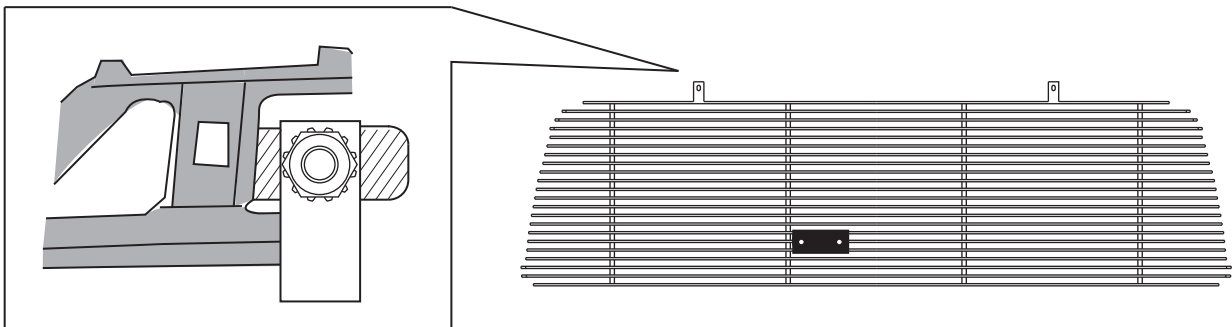

8

La calandre à barres étant montée, réinstallez l'habillage de calandre sur le véhicule en suivant l'ordre inverse des étapes de la dépose. Assurez-vous de rattacher la tige de verrouillage du capot.

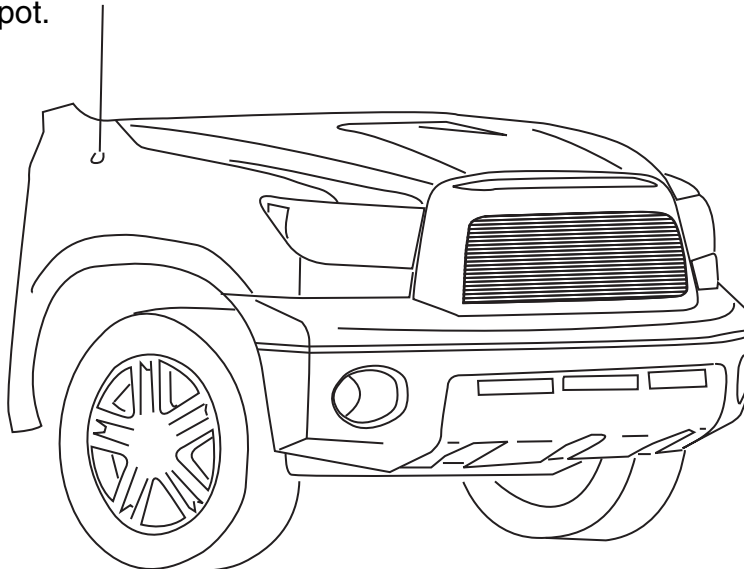

9

Entretien et nettoyage

Pour garder belle votre Calandre à Barres LUND®, il ne faut qu'utiliser de l'eau, un liquide doux de nettoyer, et un torchon doux de coton pour nettoyer et secher la calandre. Les poudres fortes a nettoyer peuvent gratter ou mater la calandre.

Si la calandre se matte, vous pouvez utiliser un poli non-abrasif de haut qualité, disponible commercialement, qui est recommandé pour le type de metal de votre calandre.

Si vous avez des questions au sujet du soin de votre calandre LUND®, veuillez téléphonez a 800-328-5863.

Félicitations

Vous vous êtes procuré l'un des nombreux produits de qualité de marque Lund® vendus par Lund International, Inc. Nous sommes très fiers de nos produits et nous désirons que votre achat vous serve pendant des années. Nous avons fait de notre mieux pour vous offrir un produit de qualité supérieure en termes d'ajustement, de durabilité, de finition et de facilité d'installation.



Lund International, Lund Accessories Division
300 Horizon Drive
Suwanee, GA 30024

Téléphone : 1 800 328-5863 • Télécopieur : 1 800 782-5448 • Site Web : lundinternational.com

© 2005 Lund International, Inc. Tous droits réservés.

Lund® et le symbole Lund® sont des marques déposées de Lund International, Inc.





Parrilla Original

Para una instalación correcta y un mejor ajuste, porfavor lea las instrucciones ANTES de comenzar. Para asistencia técnica o reclamar piezas faltantes, llame a Atención al cliente al 1-800-328-5863.

Información Importante de Seguridad



CAUTION
PRECAUCIÓN
ATTENTION

Para evitar el riesgo de los daños corporales o de los daños materiales:

- Use gafas de seguridad cuando instale la parrilla de billete.
- Tenga cuidado al trabajar con el taladro.
- Compruebe la separación del vehículo.
- Cerciérese de que la parrilla del billete esté asegurada en lugar y despeje todas las peizas móviles del vehículo.
- Compruebe rutinariamente la seguridad del material.
- Evite el uso de lavacoches automaticos con cepillos.

Contenido

Las ilustraciones pueden variar sobre el uso

Parrilla Original

A

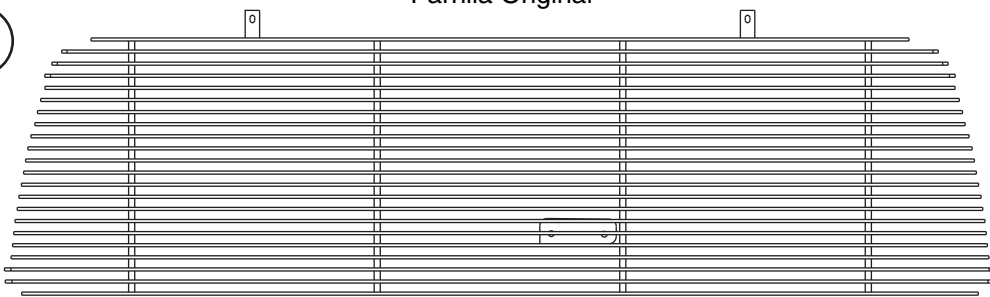

B

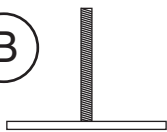

2 - Soportes de Montaje

C



2 - Arandelas de #10 SAE

D



2 - Tuercas Kep de 10/32

Herramientas Necesarias

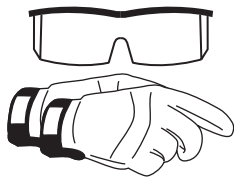

Gafas de seguridad
y guantes

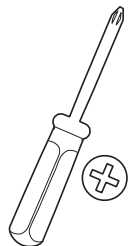

Desarmador
de Cruz

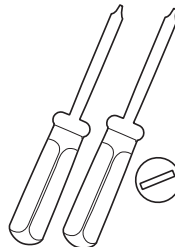

2 Desarmadors
Planos

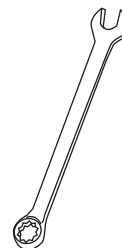

Llave de 10mm



Esmeríl o
Lijadora

Shipping Note

A veces los productos de billete se pueden doblar en el proceso de envío. Usted quizás tenga que doblarlas a mano para obtener la figura deseada.

Remueva el encarte de plástico que se encuentra encima de la concha, usando un desarmador de cabeza plana y removiendo los tornillos de montaje.

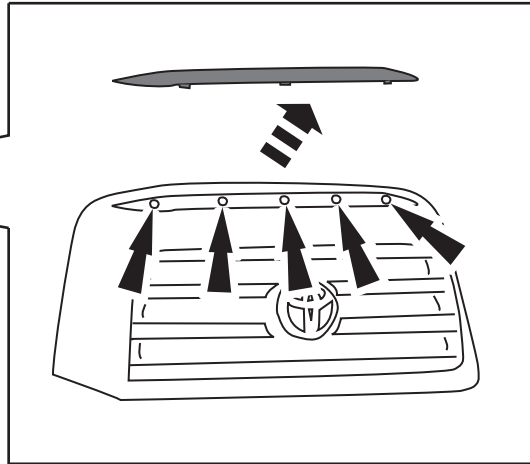
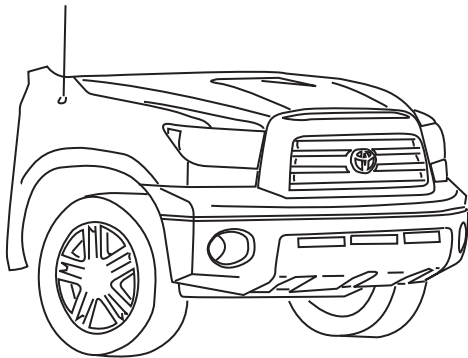

1

Abra el capó y remueva la concha de la parrilla, desconectando la barra pegada al capo y removiendo las herramientas de montaje.

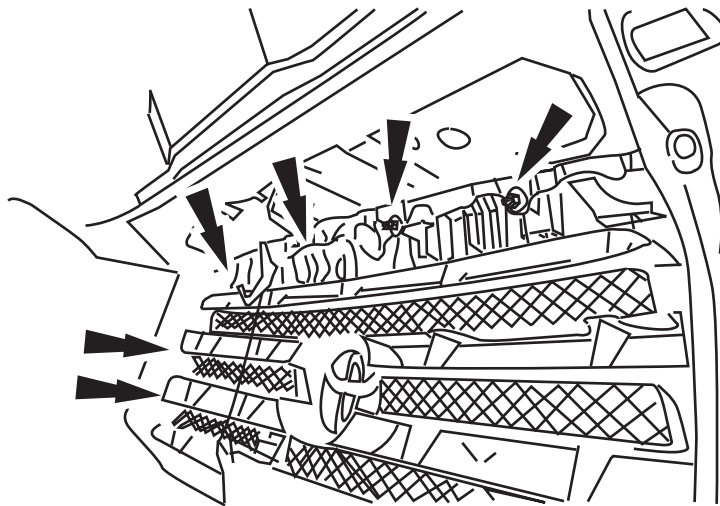

2

Remueva la barra negra de soporte del pie de la concha de la parrilla. Por la espalda del encarte, remueva el soporte que asegura el capó.

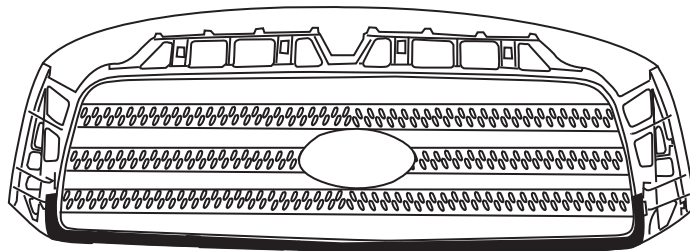

Barra Negra de la Ayuda

Soporte del Cierre de la Capilla

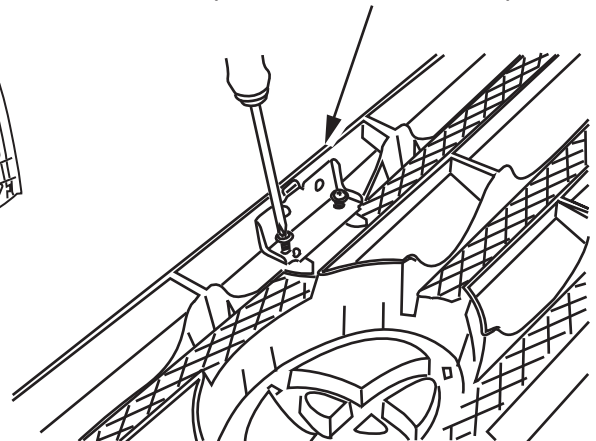

3

Usando uno o dos desarmadores de cabeza plana, según lo que Ud. necesite. Remueva el encarte de plástico de la concha de la parrilla. Es más fácil empezar de un lado y moverse hasta el otro lado.

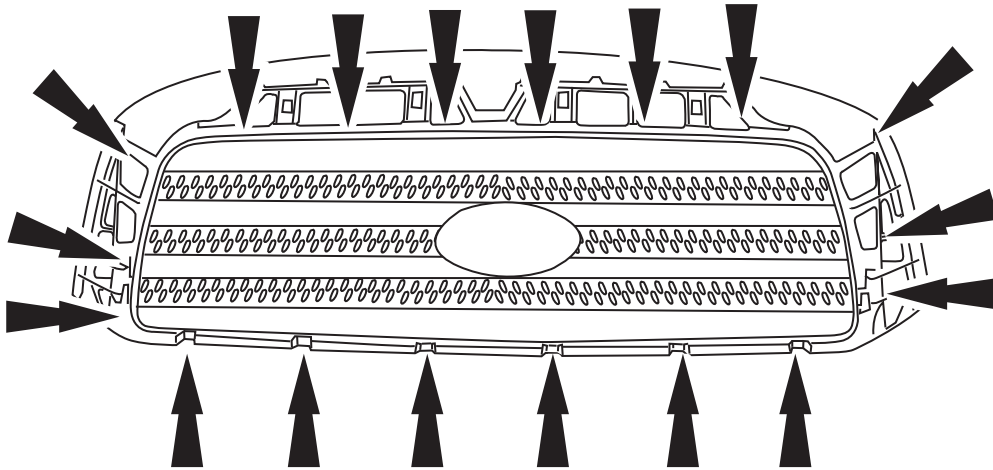

4

Por el centro del encarte, use un esmeril para cortar las barras de la parrilla original.

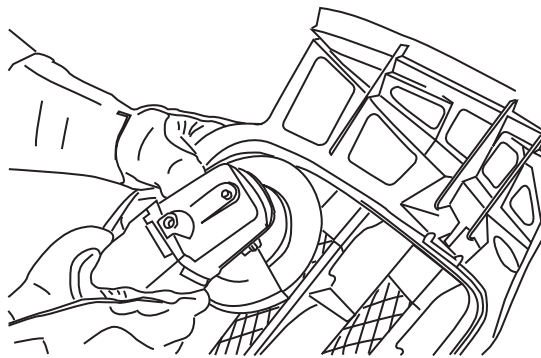

Antes de Cortar

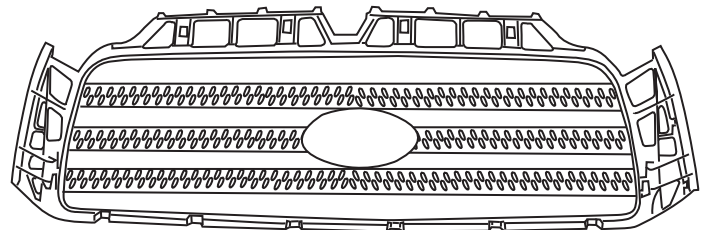

Después de Cortar

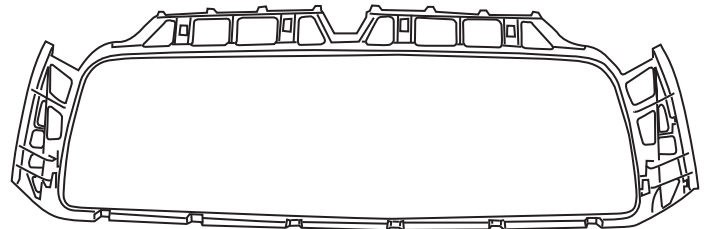

5

Inserte de golpe el encarte en su lugar. Inserte por atrás la parrilla de billete en la concha de la parrilla.

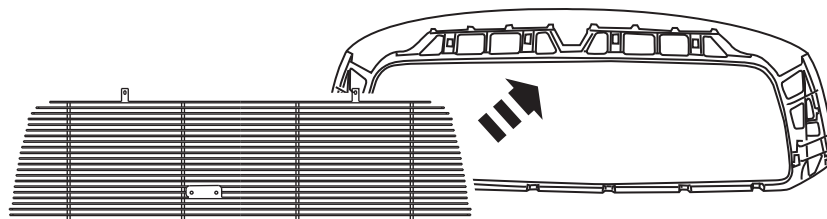

6

Una vez que la parrilla de billete esté en su lugar, instale la barra negra de soporte en su posición original sobre la parrilla de billete. Instale el soporte que asegura el capó en la lengüeta adecuada, usando las herramientas originales.

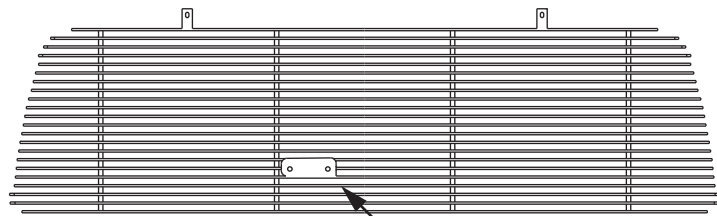

Lengüeta del Montaje del Soporte del Cierre de la Capilla

7

Enganche las lengüetas de montaje debajo del encarte de la parrilla, asegurándose que la tachuela se vea por el agujero que se encuentra en la lengüeta de la parrilla de billete. Use las herramientas proporcionadas para completar el montaje. **Advertencia: ¡No apriete demasiado las tuercas!**

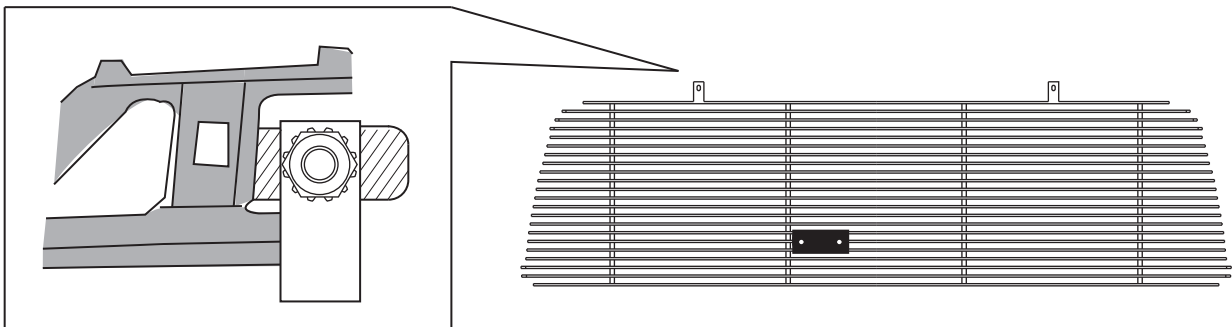

8

Una vez que la parrilla de billete esté instalada, instale de nuevo el ensamblaje de la concha de parrilla en el orden contrario al de removerlo. Asegúrese de reconectar la barra que asegura el capó.

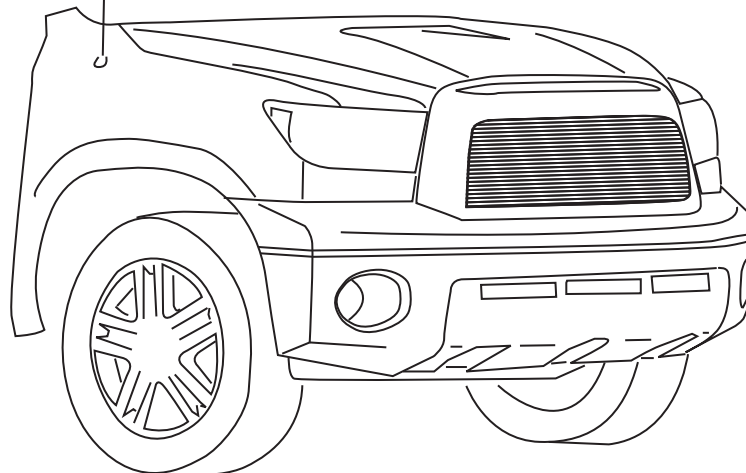

9

Cuidado y Limpieza

Para mantener lindo su parilla LUND®, se recomienda usar solo agua, un detergente suave, y un trapo suave de algodón para limpiar y secar la parilla. Los detergentes fuertes pueden rasgar o delustrar la parilla.

Si la parilla se rasca o se delustra, se puede usar una crema de pulimento no abrasiva de alta calidad, disponible en las tiendas, que se recomienda para el tipo de metal de su parilla.

Si tiene algún pregunta sobre el cuidado de su parilla LUND®, favor de llamar a 800-328-5863.

¡Felicidades!

Ha comprado uno de los tantos productos de calidad marca Lund® que ofrece Lund International, Inc. Nos sentimos muy orgullosos de nuestros productos y deseamos que disfrute durante años de su inversión. Nos hemos esforzado para asegurarnos de que su producto sea de la mejor calidad en términos de ajuste, durabilidad, acabado y facilidad de instalación.



Lund International, Lund Accessories Division
300 Horizon Drive
Suwanee, GA 30024

Teléfono 800-328-5863 • Fax 800-782-5448 • Visítenos en www.lundinternational.com

© 2005 Lund International, Inc. Todos los derechos reservados.
Lund® y el logotipo de Lund® son marcas registradas de Lund International, Inc.

