

Care and Cleaning

To keep your billet grille looking their best, we recommend using only mild soap and water and a soft cotton cloth to wash and dry it. Use of rough cleaning agents or cloths may scratch or dull your billet grille.

Should your billet grille become scratched or dull, we recommend TRENZ® Metal Polish to bring back the mirror finish. There are three grades of TRENZ® Metal Polish (Coarse, Medium and Fine) that will help you keep your billet grille looking brand new. Select the TRENZ® Metal Polishes best for your needs:

1. Course (Red) Polish – For severe scratches and pitted problems.
2. Medium (Green) Polish – For light scratches and dulling problems.
3. Fine (White) Polish – To bring back the mirror finish.

TRENZ® Metal Polish can be used on all metal products, including aluminum, stainless steel, brass and copper. If you have additional questions or concerns on the maintenance of your Lund® billet grille, please call us at 800-328-5863. You may also use high quality commercially available polish recommended for aluminum accessories.

Congratulations!

You have purchased one of many quality Lund® branded products offered by Lund International, Inc. We take the utmost pride in our products and want you to enjoy years of satisfaction from your investment. We have made every effort to ensure that your product is top quality in terms of fit, durability, finish and ease of installation.



Lund International, Lund Accessories Division
775 Tipton Industrial Drive, Building 2, Suite F
Lawrenceville, GA 30045

Phone 800-328-5863 • Fax 800-782-5448 • Visit us at lundinternational.com

© 2005 Lund International, Inc. All rights reserved.
Lund® and the Lund® logo are trademarks of Lund International, Inc.



Installation Instructions

Part Number 89014

I-sheet Rev. A2



Framed Perimeter Grille

For proper installation and best possible fit, please read all instructions **BEFORE** you begin.
For technical assistance or to obtain missing parts, please call Customer Relations at 1-800-328-5863.

Important Safety Information



CAUTION
PRECAUCIÓN
ATTENTION

To avoid risk of personal injury or property damage:

- Wear safety glasses and gloves while installing billet inserts.
- Use caution when working with any power tools.
- Check clearance on vehicle.
- Make sure that the billet inserts are secured in place and clears all moving parts of the vehicle.
- Routinely check security of hardware.
- Do not use automatic “brush-style” car washes.

Contents

Illustrations may vary upon application

A

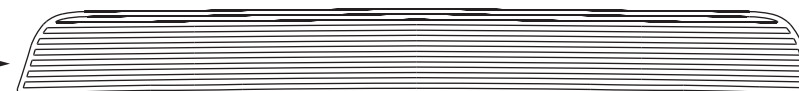

Billet Grille

B

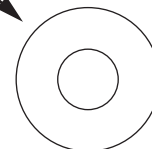

4 - 1/4 x 3/4" (W3)
Flat Washers

C



4 - 1/4-20 (N3)
Nylon Lock Nuts

D

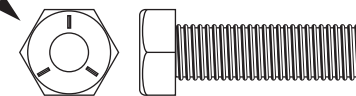

2 - 1/4-20 x 1-1/2"
(G53) Cap Screws

Tools Required

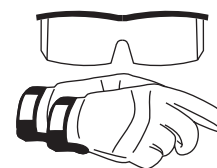

Safety Glasses
and Gloves

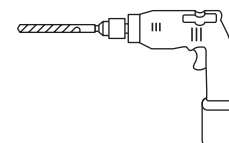

Drill with
1/8" Drill Bit

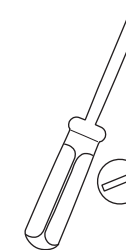

Flat Head
Screwdriver



7/16" Wrench

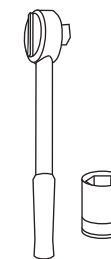

Ratchet with
7/16" Socket

Shipping Note

Sometimes the billet products get bent in the shipping process. You may need to hand bend them to attain the desired shape.

Installation Steps

Illustrations may vary upon application

Using a flat head screwdriver remove the four plastic rivets on top of stock grille and set aside for later use. Turn the plastic clips 45 degrees to release them. The clips are located on insides of mesh and bottom of grille. Remove the six plastic clips from the vehicle and reattach them to the grille shell.

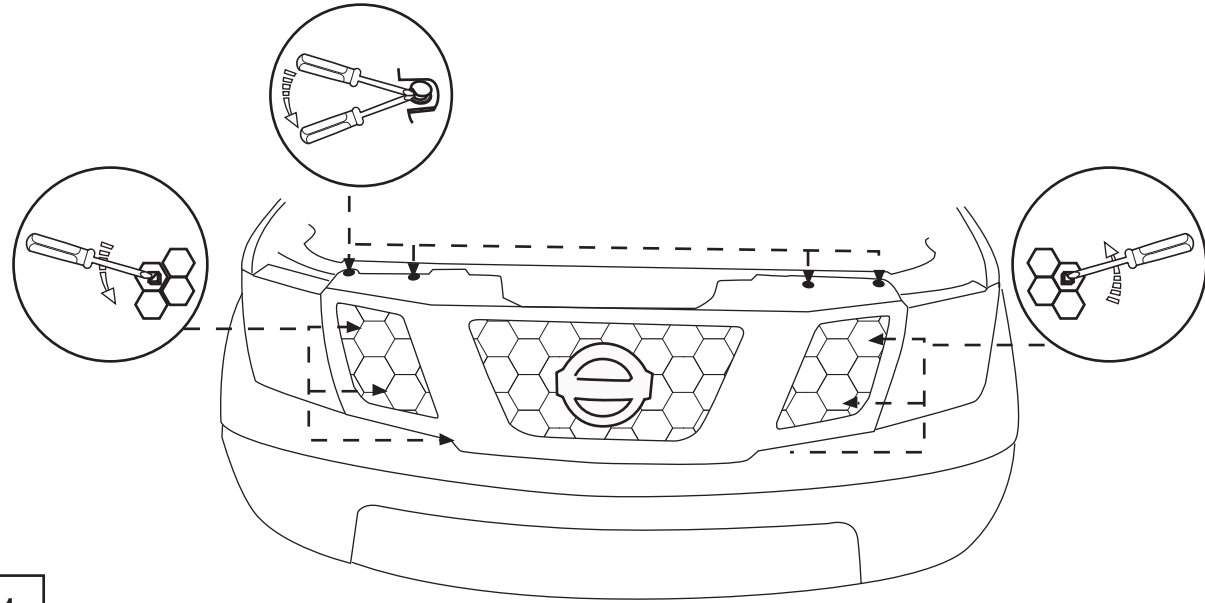

1

Place bolt into mounting tab and secure with nylon locknuts nut as show in diagram.

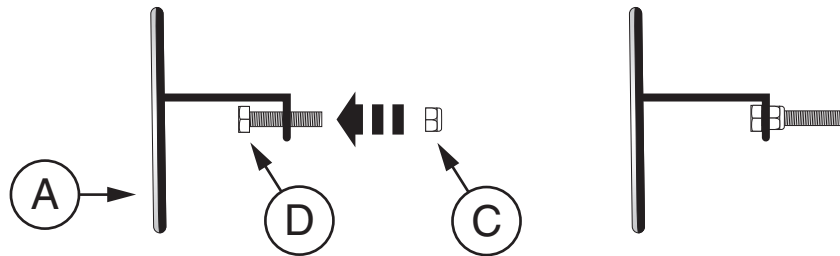

2

Place bumper grille over bumper opening and make sure that the billet grille is centered. Mark the holes where the set screws touch the mesh.

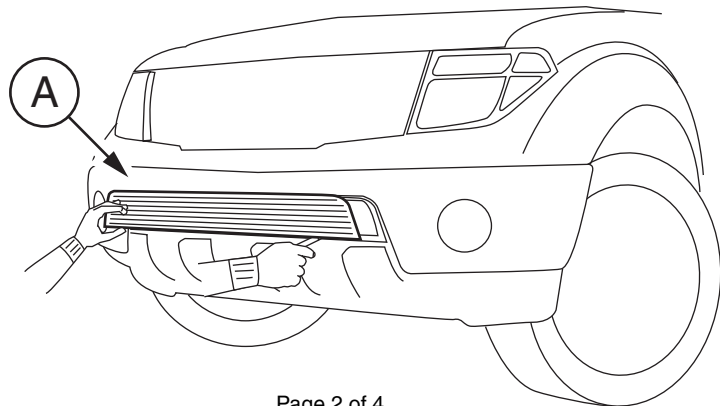

3

Drill out the holes marked with a 1/4" drill bit.

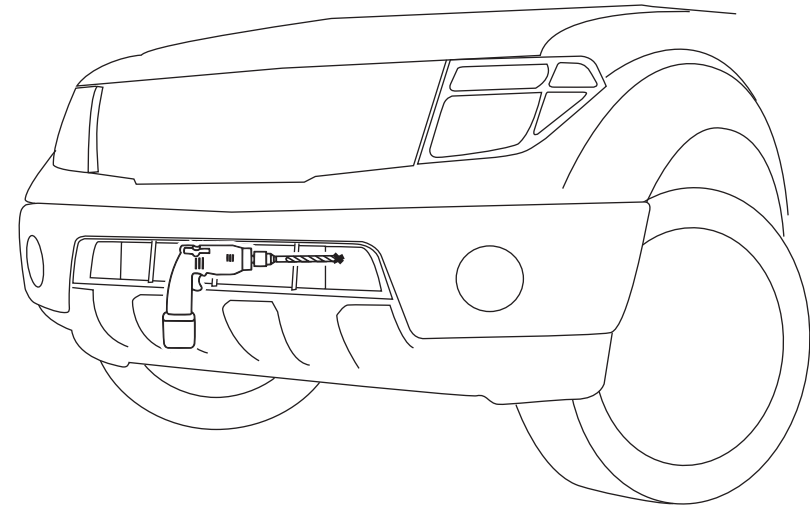

4

Insert billet grille into bumper opening and install billet grille as show in diagram.

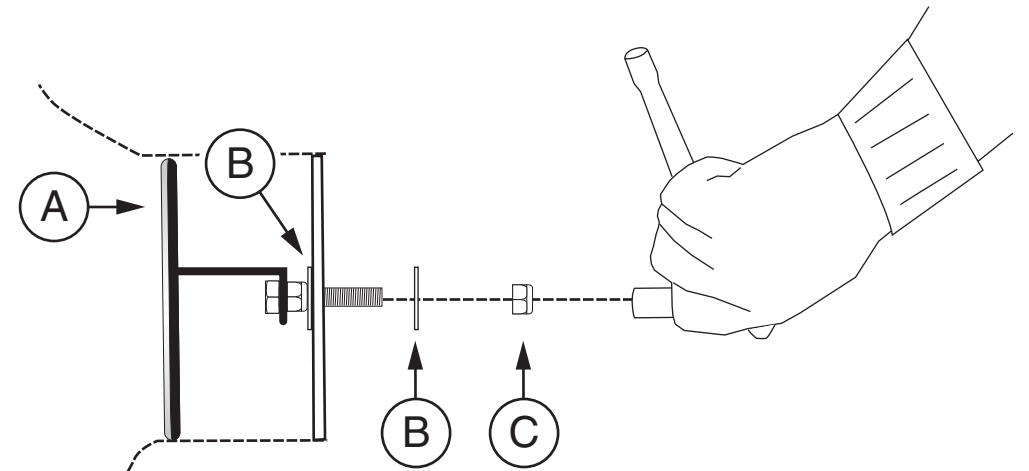

5

Reinstall grille shell on vehicle. (Remember to place plastic clips back on the grille shell before installing it on to the vehicle.)

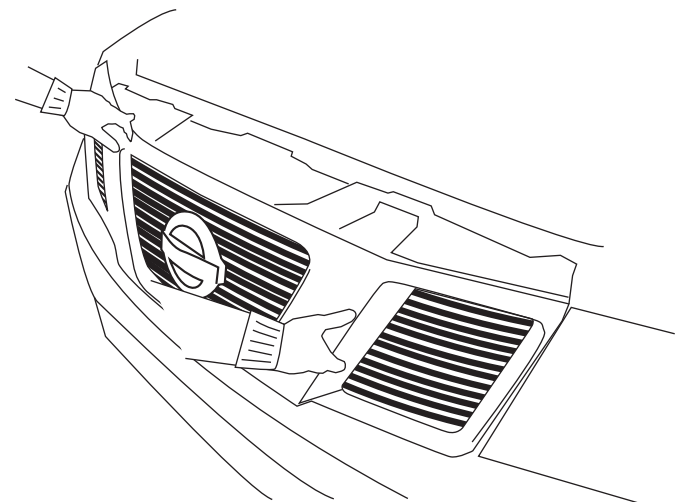

6