

## Care and Cleaning

To keep your billet grille looking their best, we recommend using only mild soap and water and a soft cotton cloth to wash and dry it. Use of rough cleaning agents or cloths may scratch or dull your billet grille.

Should your billet grille become scratched or dull, we recommend TRENZ® Metal Polish to bring back the mirror finish. There are three grades of TRENZ® Metal Polish (Coarse, Medium and Fine) that will help you keep your billet grille looking brand new. Select the TRENZ® Metal Polishes best for your needs:

1. Course (Red) Polish – For severe scratches and pitted problems.
2. Medium (Green) Polish – For light scratches and dulling problems.
3. Fine (White) Polish – To bring back the mirror finish.

TRENZ® Metal Polish can be used on all metal products, including aluminum, stainless steel, brass and copper. If you have additional questions or concerns on the maintenance of your Lund® billet grille, please call us at 800-328-5863. You may also use high quality commercially available polish recommended for aluminum accessories.

## Congratulations!

You have purchased one of many quality Lund® branded products offered by Lund International, Inc. We take the utmost pride in our products and want you to enjoy years of satisfaction from your investment. We have made every effort to ensure that your product is top quality in terms of fit, durability, finish and ease of installation.



Lund International, Lund Accessories Division  
775 Tipton Industrial Drive, Building 2, Suite F  
Lawrenceville, GA 30045

Phone 800-328-5863 • Fax 800-782-5448 • Visit us at [lundinternational.com](http://lundinternational.com)

© 2005 Lund International, Inc. All rights reserved.

Lund® and the Lund® logo are trademarks of Lund International, Inc.



## Installation Instructions

Part Number 89019

I-sheet Rev. A3



## Framed Perimeter Grille

For proper installation and best possible fit, please read all instructions **BEFORE** you begin.  
For technical assistance or to obtain missing parts, please call Customer Relations at 1-800-328-5863.

## Important Safety Information



CAUTION  
PRECAUCIÓN  
ATTENTION

To avoid risk of personal injury or property damage:

- Wear safety glasses and gloves while installing billet inserts.
- Use caution when working with any power tools.
- Check clearance on vehicle.
- Make sure that the billet inserts are secured in place and clears all moving parts of the vehicle.
- Routinely check security of hardware.
- Do not use automatic “brush-style” car washes.

## Contents

Illustrations may vary upon application

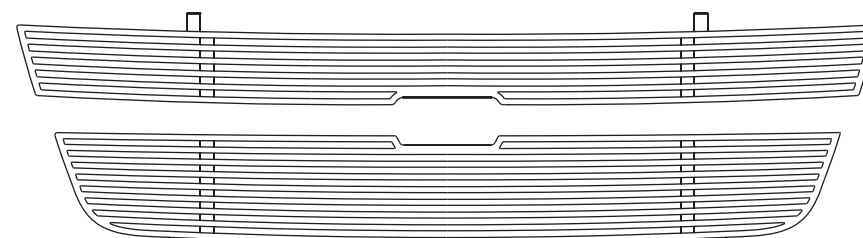

2 - Small Mounting  
Brackets

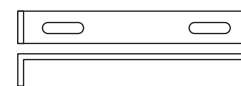

2 - Large Mounting  
Brackets

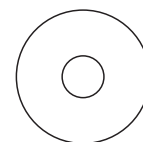

6 - 3/16 x 3/4" (W20)  
Black Washers



6 - 10/32 (N6)  
Kep Nuts



4 - 1/8 x 1/2" (R2)  
Pop Rivets

## Tools Required



Safety Glasses  
and Gloves

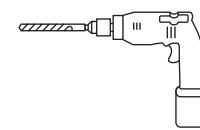

Drill with  
1/8" Drill Bit



Flat Head  
Screwdriver



Die  
Grinder



Rivet  
Gun



Ratchet with  
10mm Socket

## Shipping Note

Sometimes the billet products get bent in the shipping process. You may need to hand bend them to attain the desired shape.

# Installation Steps

Illustrations may vary upon application

Open the hood. Remove the top pin securing the turn signal light to the radiator support. Remove the turn signal light.

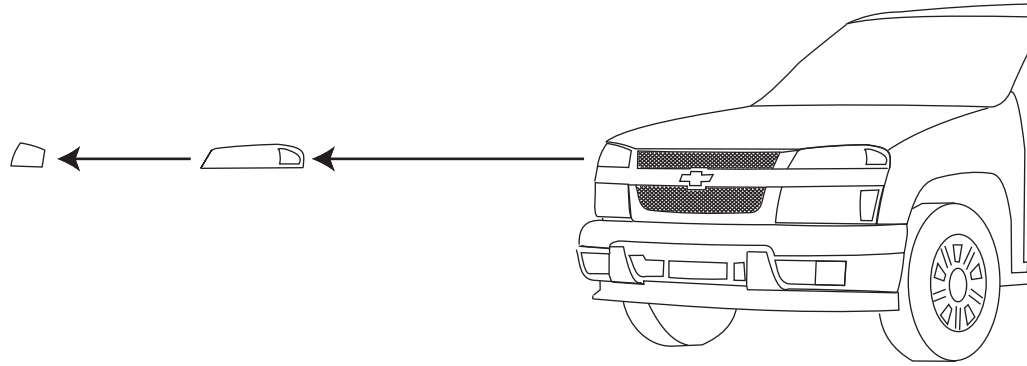

1

Use a flat head screwdriver to unsnap each clip that holds the stock grille shell to the vehicle. Each arrow indicates approximate location of each clip.

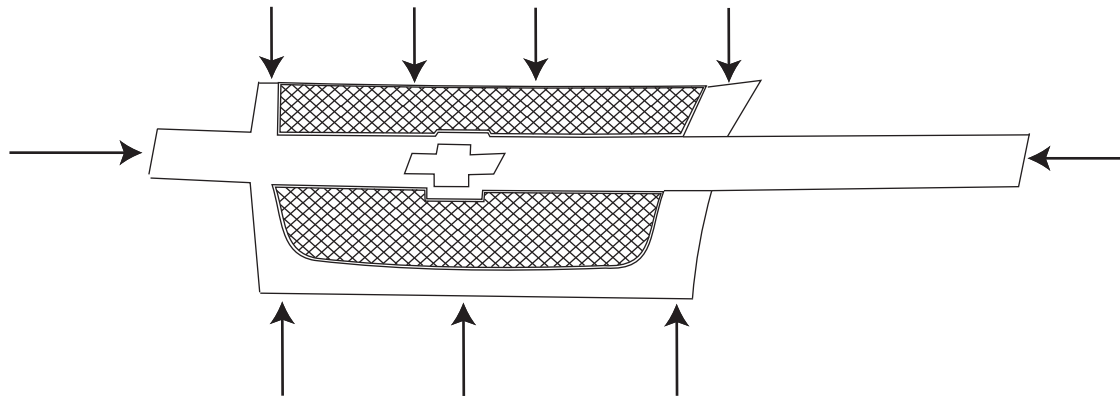

2

Use a die grinder to cut away the inner mesh. **Note: Be sure to leave the inner lip!**

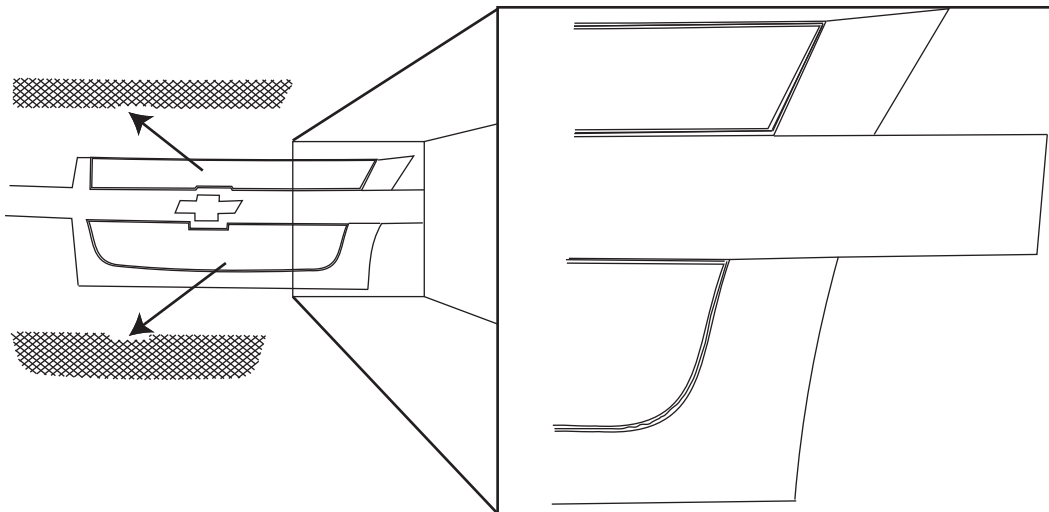

3

Insert the billet grille into the front of the bumper shell. The billet grille mounting studs will stick out past the stock mesh. Place a mounting bracket over each mounting stud and secure with the provided hardware.

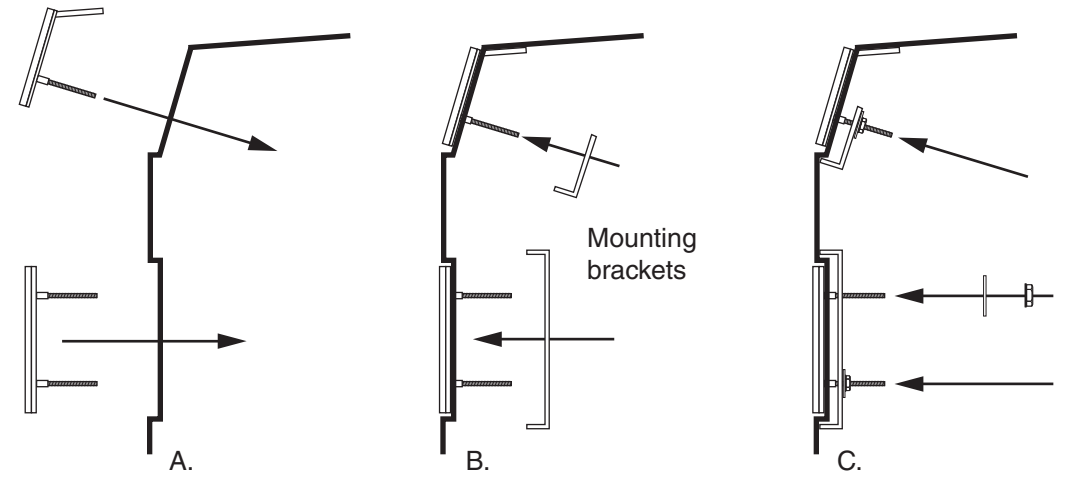

4

Drill a 1/8" hole through the top black plastic grille shell and two mounting tabs on the top billet grille. Rivet into place.

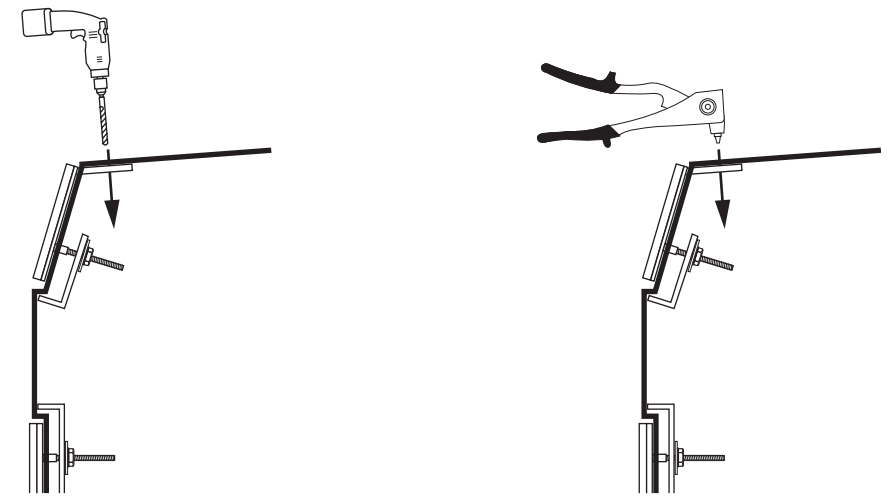

5

Reinstall the stock grille shell back into the truck and make sure everything is secure.

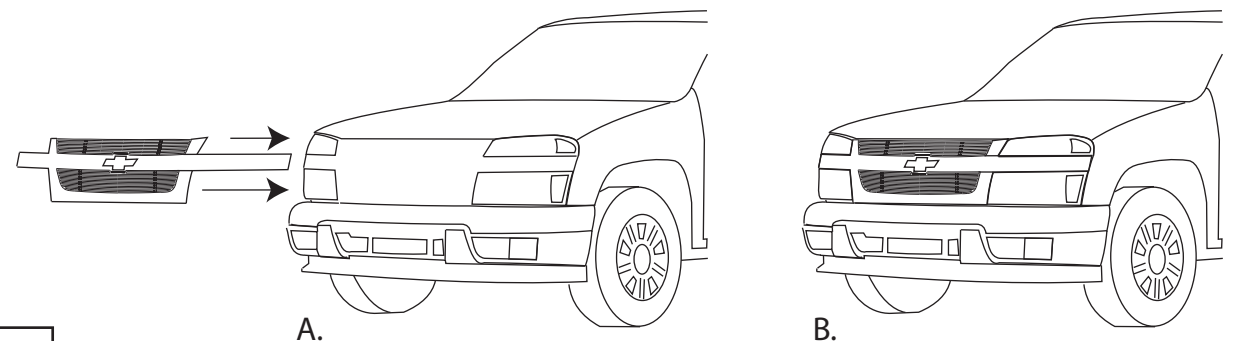

6