



Framed Perimeter Grille

For proper installation and best possible fit, please read all instructions **BEFORE** you begin.
For technical assistance or to obtain missing parts, please call Customer Relations at 1-800-328-5863.

Important Safety Information



CAUTION
PRECAUCIÓN
ATTENTION

To avoid risk of personal injury or property damage:

- Wear safety glasses and gloves while installing billet inserts.
- Use caution when working with any power tools.
- Check clearance on vehicle.
- Make sure that the billet inserts are secured in place and clears all moving parts of the vehicle.
- Routinely check security of hardware.
- Do not use automatic “brush-style” car washes.

Contents

Illustrations may vary upon application

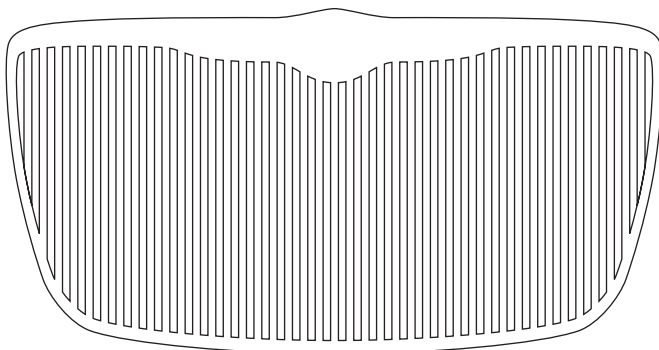

6 - Panel Retainers

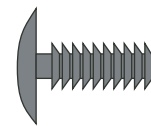

20 - 1/4x1/2" (W2)
Washers



20 - 10/32 (N6)
Kep Nuts



Tools Required

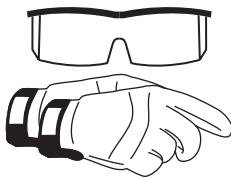

Safety Glasses
and Gloves

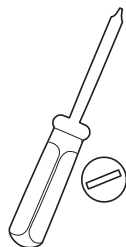

Flat Head
Screwdriver

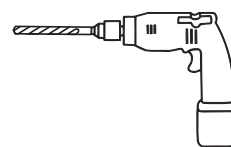

Drill with
1/8" Drill Bit

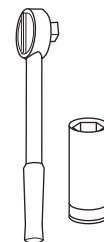

Ratchet with
3/8" Deep Socket

Shipping Note

Sometimes the billet products get bent in the shipping process. You may need to hand bend them to attain the desired shape.

Installation Steps

Illustrations may vary upon application

Open the hood and remove the black radiator cover by pulling it upward away from the vehicle. Save the cover for reinstallation.



1

Remove the four plastic rivets holding the top of the front clip. Use a flat head screwdriver to pry the center of the rivet up, then pull the rivet out. Save the rivets for reinstallation.



From the back of the bumper, use a Robertson screwdriver to remove the two plastic screws that hold the stock grille to the foam bumper.

2

Remove the ten screws that hold the bottom of the front clip in place. Save the screws for reinstallation.



3

Locate the three plastic rivets that are located inside the fender well. The rivets are removed by drilling a 1/8" hole in the center of the rivet.



4

Installation Steps

Illustrations may vary upon application

Pull the inner plastic fender well back to allow for clearance to reach inside. Remove the 10mm bolt that holds the front bumper to the corner of the fender. Repeat steps 5-6 on the other wheel well.

Pull the bumper forwards off the car.

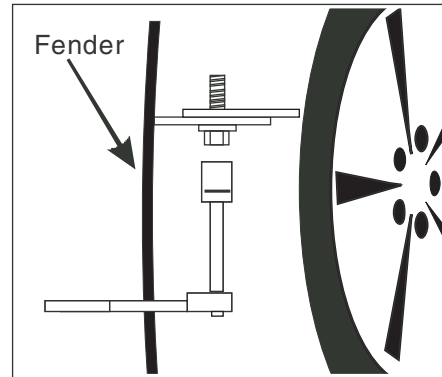

5

Use a Phillips head screwdriver to unscrew the stock grille from the bumper cover. Then drill a 3/8" hole through each of the original mounting holes from the stock grille shell.

6

On the billet grille, screw one 10-32 Kep Nut backwards on each mounting stud about 1/2" down. Then put a washer on each mounting stud.

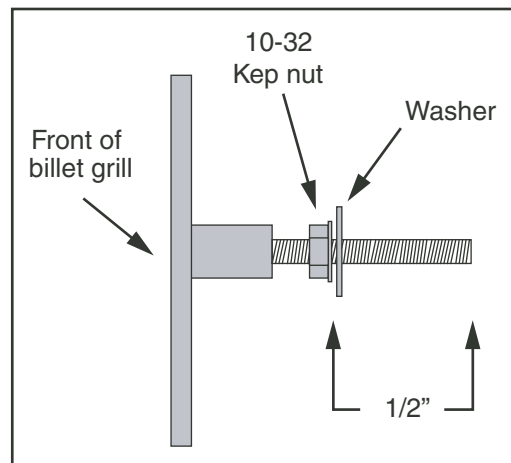

7

Carefully insert the billet grille into the front of the bumper cover. Line up all the mounting studs to each 3/8" hole in the bumper cover.

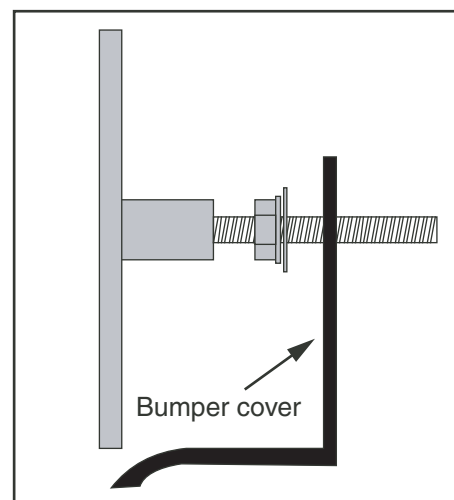

8

Insert the billet grille into the bumper cover and secure it with a washer and Kep Nut on each mounting stud.

Start with the bottom studs and work your way toward the top.

Adjust the backwards Kep Nut (in step 8) to set the depth of the grille.

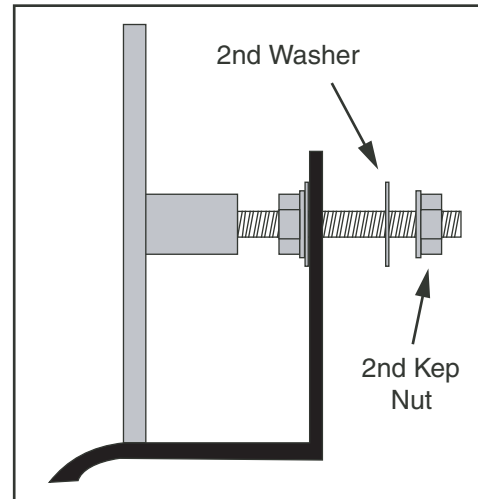

9

Reinstall the bumper cover in the reverse order you removed it.

Replace the plastic rivets you drilled out with the included black plastic panel retainers.

10

Care and Cleaning

To keep your billet inserts looking their best, we recommend using only mild soap and water and a soft cotton cloth to wash and dry it. Use of rough cleaning agents or cloths may scratch or dull your billet inserts.

Should your billet inserts become scratched or dull, we recommend TRENZ® Metal Polish to bring back the mirror finish. There are three grades of TRENZ® Metal Polish (Coarse, Medium and Fine) that will help you keep your billet inserts looking brand new. Select the TRENZ® Metal Polishes best for your needs:

1. Course (Red) Polish – For severe scratches and pitted problems.
2. Medium (Green) Polish – For light scratches and dulling problems.
3. Fine (White) Polish – To bring back the mirror finish.

TRENZ® Metal Polish can be used on all metal products, including aluminum, stainless steel, brass and copper. If you have additional questions or concerns on the maintenance of your Lund® billet inserts, please call us at 800-328-5863. You may also use high quality commercially available polish recommended for aluminum accessories.

Congratulations!

You have purchased one of many quality Lund® branded products offered by Lund International, Inc. We take the utmost pride in our products and want you to enjoy years of satisfaction from your investment. We have made every effort to ensure that your product is top quality in terms of fit, durability, finish and ease of installation.



Lund International, Lund Accessories Division
775 Tipton Industrial Drive, Building 2, Suite F
Lawrenceville, GA 30045

Phone 800-328-5863 • Fax 800-782-5448 • Visit us at lundinternational.com

© 2005 Lund International, Inc. All rights reserved.
Lund® and the Lund® logo are trademarks of Lund International, Inc.

