

Care and Cleaning

To keep your billet grille looking their best, we recommend using only mild soap and water and a soft cotton cloth to wash and dry it. Use of rough cleaning agents or cloths may scratch or dull your billet grille.

Should your billet grille become scratched or dull, we recommend TRENZ® Metal Polish to bring back the mirror finish. There are three grades of TRENZ® Metal Polish (Coarse, Medium and Fine) that will help you keep your billet grille looking brand new. Select the TRENZ® Metal Polishes best for your needs:

1. Course (Red) Polish – For severe scratches and pitted problems.
2. Medium (Green) Polish – For light scratches and dulling problems.
3. Fine (White) Polish – To bring back the mirror finish.

TRENZ® Metal Polish can be used on all metal products, including aluminum, stainless steel, brass and copper. If you have additional questions or concerns on the maintenance of your Lund® billet grille, please call us at 800-328-5863. You may also use high quality commercially available polish recommended for aluminum accessories.

Congratulations!

You have purchased one of many quality Lund® branded products offered by Lund International, Inc. We take the utmost pride in our products and want you to enjoy years of satisfaction from your investment. We have made every effort to ensure that your product is top quality in terms of fit, durability, finish and ease of installation.



Lund International, Lund Accessories Division
775 Tipton Industrial Drive, Building 2, Suite F
Lawrenceville, GA 30045

Phone 800-328-5863 • Fax 800-782-5448 • Visit us at lundinternational.com

© 2005 Lund International, Inc. All rights reserved.
Lund® and the Lund® logo are trademarks of Lund International, Inc.

Installation Instructions

Part Number 89086

I-sheet Rev. A2



Framed Perimeter Grille

For proper installation and best possible fit, please read all instructions **BEFORE** you begin.
For technical assistance or to obtain missing parts, please call Customer Relations at 1-800-328-5863.

Important Safety Information



CAUTION
PRECAUCIÓN
ATTENTION

To avoid risk of personal injury or property damage:

- Wear safety glasses and gloves while installing billet inserts.
- Use caution when working with any power tools.
- Check clearance on vehicle.
- Make sure that the billet inserts are secured in place and clears all moving parts of the vehicle.
- Routinely check security of hardware.
- Do not use automatic “brush-style” car washes.

Contents

Illustrations may vary upon application



9 - 10/32
Kep Nuts



9 - 1/4" x 1"
Black Fender Washer



Tools Required



Safety Glasses
and Gloves

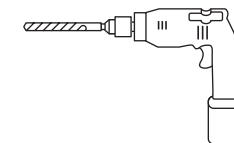

Drill with
1/8" Drill Bit

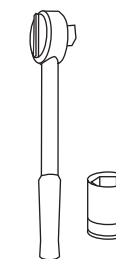

Ratchet with
3/8" & 10mm Socket

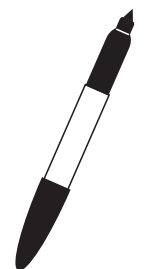

Felt Tip
Pen

Shipping Note

Sometimes the billet products get bent in the shipping process. You may need to hand bend them to attain the desired shape.

Caution

Grille covers may reduce airflow which may result in higher operating temperatures. Monitor your vehicle's operating temperature to ensure proper operating conditions.

Installation Steps

Remove the bolts holding the bottom of the bumper to the skidplate. Save bolts for re-installation.

1

Insert the center bumper grille into the center bumper opening. Make sure that the billet grille is centered and that the set screws fit between the mesh.

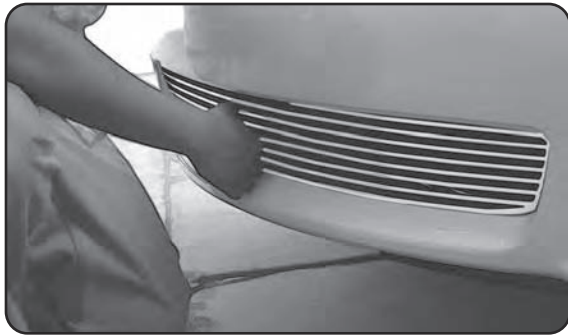

2

Reach in and up to the back of the center grille through the space between the skid plate and the front end to slide washers over the set screws use the kep nuts to secure in place. **Caution: Do not over-tighten kep nuts!**

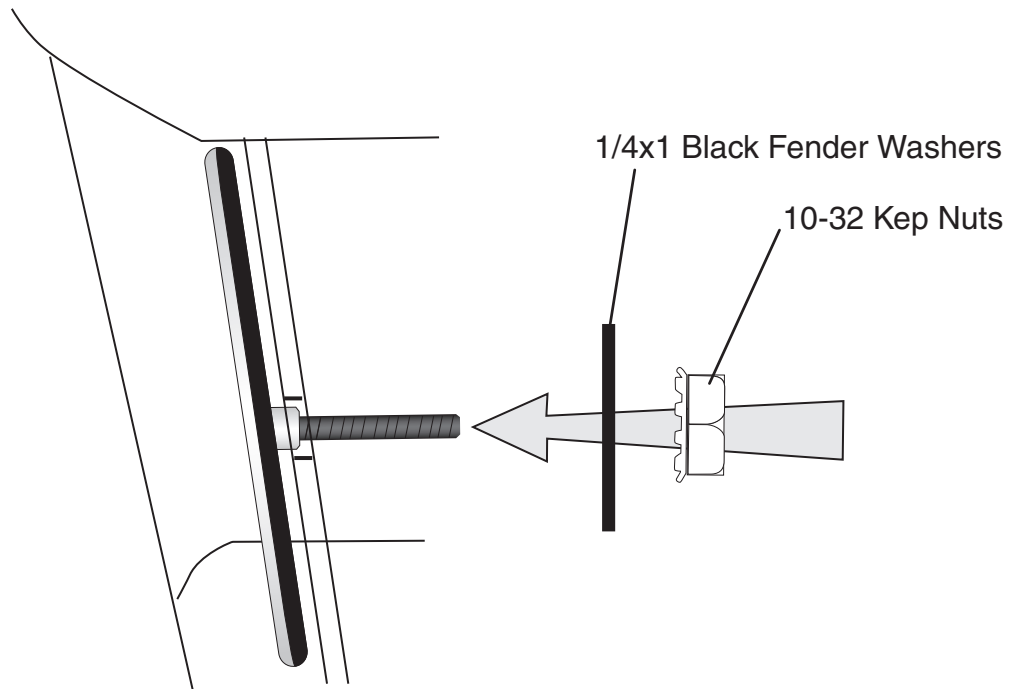

3

Place the side bumper grille over the mesh and make sure that the billet grille is centered. Mark the holes where the setscrew touch the mesh. Then drill out the holes marked with a 1/4" drill bit.



4

Place the left side bumper grille into the grille opening making sure to line up the set screws with the holes drilled. Reach in and up to the back of the side grille, through the space between the skid plate and the front end to slide washers over the set screws. Use the kep nuts to secure grille in place. **Caution: do not over-tighten kep nuts!** Repeat steps 4-5 for the right side bumper grille.

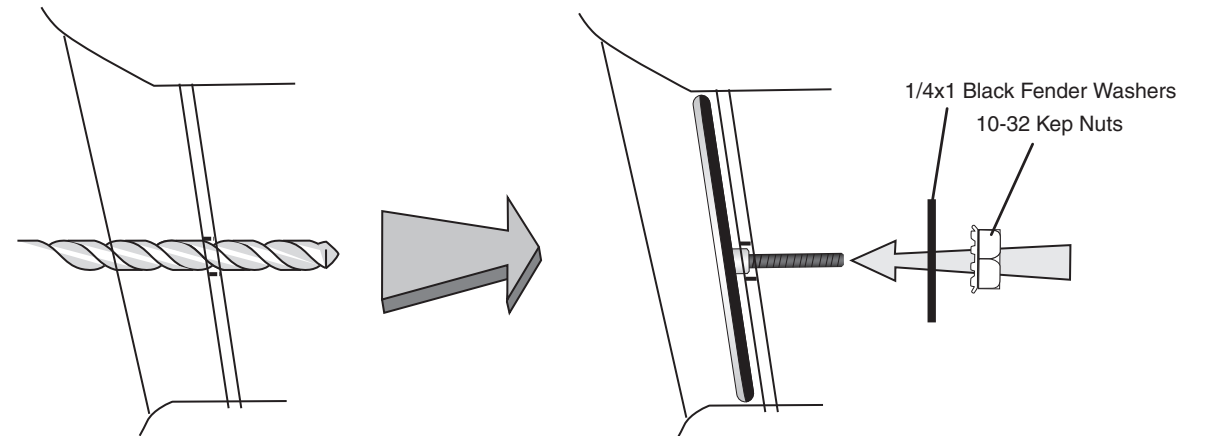

5