



**Mallory Distributors Manual
Standard And Vacuum Advance
Single And Dual Point**



TROUBLESHOOTING GUIDE FOR A POINT STYLE DISTRIBUTOR

The following are some basic steps to take when troubleshooting a Point Style Distributor. Of course, the first thing that should be checked is the condition of the cap and rotor, looking for carbon tracking or corrosion on the terminals or where the plug wires connect. Also check the spark plug wires with an Ohmmeter to insure they have the proper resistance.

IF THERE IS NO TRIGGER SIGNAL TO THE COIL

If the box powers up but does not fire the coil and the white wire is being used as the trigger source, the following tests should be done:

1. Remove the cap, turn the motor over and look at the points to see if they are opening and closing. If they are, see if they are sparking. On a dual point distributor, one set will open with no spark and the other will spark when it opens. If the spark is a big fat one, then the condenser is bad and needs to be replaced.
2. If no spark is visible, check to see if the points or wires are shorting to ground either at the points or at the primary terminal screw going through the housing. Also check where the contact spring connects to the main frame of the points and make sure the insulator is not melted.
3. If all of this looks good then look to see if there is anything else connected to the coil (-) terminal. If so, remove it and see if the motor fires.
4. Last but not least, there could be a problem with the coil itself or the coil wire going back to the cap. To check the coil, use the following test procedure.
NOTE: This test should only be done on "stock type" coils. **DO NOT** try this test with "CD Only" coils, such as the Mallory 28880 or ACCEL 140019 and 140010.

1. Disconnect the distributor from the coil (-) terminal, taking it out of the loop and allowing the test to be done properly.
2. Disconnect the wires coming from the CD box (if so equipped) connected to the coil (+ and -) terminals and connect the ignition switch 12 volts wire to the coil (+) terminal of the coil.

3. Connect a 24" piece of wire to the coil (-) of the coil.
4. Pull the coil wire out of the distributor cap and get it to where you can jump a spark to ground with it.
5. Turn the ignition to the "ON" position.
6. Rapidly tap the 24" wire to ground. This will fire the coil. You should get a 1/4" to 3/8" spark out of the high voltage coil wire to ground. If you do then the coil and coil wire are good and working.
7. If no spark to ground, change out the coil wire and do the test again. If still no spark, the coil is bad and needs to be replaced.

IF THE POINTS BURN UP OR THE CONDENSER FAILS FREQUENTLY

1. Check and make sure that everything is well grounded to the engine block. Condenser failure is often a grounding problem. Make sure all grounding surfaces are clean of free of paint, grease, or oil.
2. If the condenser needs changing, make sure that the bracket is also changed at the same time. The brackets are basically a one-shot use part. They are designed to scratch through the rust preventative coating on the condenser when it is installed. In problem applications, scuffing off this coating will guarantee a good ground.
3. Make sure that the heads are grounded to the block. With all of the coatings and sealers that are used on gaskets and bolts, especially on race applications, the cylinder heads can be poorly grounded. A simple ground strap between the block and each head can make a big difference.
4. A simple ground strap from the distributor body to the block, not the intake manifold can also solve a problem. The strap can be connected to a screw that attaches the vacuum advance chamber or the condenser bracket. Care must be taken that the screw is replaced with a slightly longer one to allow for the thickness of a spade or ring terminal. Make sure that the screw doesn't come in contact with anything that is revolving inside like the advance

weights when they are fully advanced. The point plate also moves and must be free of anything that could bind it. The screw must be flush with the inside of the bowl. Another option would be to put a clamp on the lower shank area of the housing. The distributor clamp is not a reliable ground.

5. Make sure that the block is also grounded to the frame.

MECHANICAL ISSUES EFFECTING DISTRIBUTORS

IF THE TIMING IS ALL OVER THE PLACE WHEN CHECKED WITH A TIMING LIGHT

1. First check for excessive wear in the gears. Grab the rotor and turn it back and forth. If it has excessive play, check for wear on both the camshaft and the distributor.
2. If the gears appear normal, use a socket and a breaker bar to gently rotate the crankshaft back and forth. The key here is to see how far the crank rotates before the rotor moves. Anything beyond a few degrees indicates a worn timing chain/gear assembly that needs to be replaced.
3. Check the advance. The simple way to evaluate the advance is simply grab the rotor and turn it. This will activate the mechanical advance and give some indication if there is a problem in the distributor. If you can turn it one way against the springs and it snaps back to the original position when it is released, it is fine.
 1. If it binds, the advance is suspect and needs to be checked.
 2. If it turns but does not come back to the rest position, the springs have probably either come off or are broken.

IF THE POINTS ARE CONTINUALLY OUT OF ADJUSTMENT

1. Check the upper end of the shaft for excessive side to side movement. Lateral movement will cause the points to require constant adjustment. The only solution is to replace or rebuild the distributor.
2. Confirm that the point set is not designed for racing only with excessive spring tension. This increases rubbing block wear even with properly lubricated.



(LEGAL IN CALIFORNIA ONLY FOR RACING VEHICLES WHICH MAY NEVER BE OPERATED UPON A HIGHWAY)

INSTALLATION PROCEDURE

Step 1

Locate the spark plug wire on the original distributor cap that the engine timing is set from. (See service manual for these locations.)

Step 2

Remove the distributor cap. Do not remove the plug wires or coil wire at this time.

Step 3

Turn the engine crankshaft in the direction of rotation until the timing mark lines up with the top dead center (TDC) mark on the timing tab (See a service manual for these locations). **NOTE: Once this step is finished, DO NOT turn the crankshaft until the new distributor is installed.**

Step 4

Remove distributor primary wire connected from distributor to negative terminal of coil. If original distributor is a vacuum advance unit, note the direction that the vacuum chamber is pointing and remove the vacuum line. Remove the original distributor.

Step 5

Remove cap from Mallory distributor. If a vacuum advance unit is being replaced, turn the Mallory distributor so that the vacuum chamber is pointed in the same direction as the original. If the original had had no vacuum advance, and is being replaced by a Mallory vacuum advance unit, point the vacuum chamber so that there is room to turn the distributor for timing adjustment. In all cases, line up the rotor so that it points in the same direction as the original, and install it in the engine block. Be sure that the distributor is seated in the block.

Step 6

Rotate distributor body in opposite direction of rotor rotation until points just open. Tighten holding clamp so distributor body will not move. Place a mark on distributor body in line with the rotor blade center.

Step 7

Reinstall distributor cap. The spark plug wire tower of the cap which lines up with the mark on the distributor body is now designated No. 1 cylinder. Remove No. 1 cylinder spark plug wire from original cap and place in No. 1 tower on the Mallory distributor cap. Remove spark plug wires, one at a time, from the original cap and install in Mallory cap in the same rotation and sequence as they were removed from the original cap. Remove coil wire from original cap. Install this wire in the Mallory cap.

Step 8

Connect primary wire from negative terminal of coil to the distributor terminal.

Step 9

If installing a non-vacuum distributor, skip to step 10. For vacuum advance units, locate the original vacuum line. If none is present, a line must be run to a ported vacuum source. Do not connect this until after the engine has been timed. Temporarily plug this line.

Step 10

CAUTION: For the following procedures make sure that you and all of the wires for the timing light are clear of moving engine parts, such as the fan and any belts, power steering pumps, etc.

Connect a timing light. Install the distributor clamp and tighten it just enough so the distributor can be rotated for timing purposes. Start the engine and rotate the distributor so that the timing is as recommended by the manufacturer. Tighten the distributor clamp and make sure that timing is still correct. If not, repeat step 10.

Step 11

If a vacuum advance distributor is installed, remove the temporary plug from the vacuum line and connect it to the vacuum chamber.

GENERAL SERVICE INFORMATION

Lubrication

(Every 50 hours) apply a light film of grease on the cam lobes. Apply chassis lubricant with a hand gun to tach drive grease fitting. (Stop at the slightest back pressure.)

Centrifugal Advance

Springs are adjustable by using a screw driver in the circuit breaker plate holes. DO NOT DAMAGE the spring loops. If necessary, disassemble, place a light film of grease at the upper shaft and a light film of oil on all other parts.

Tachometer Drive Assembly

Use a suitable wrench and disassemble tach drive assembly. Clean all parts and inspect for wear. Reassemble, lubricating all parts with hand gun.

Coil Check

Remove the coil output wire from the distributor cap. Hold this wire about 1/2" away from ground. Crank engine with the ignition key "on." A reasonable snappy blue spark should be obtained. If spark output is weak, check secondary wiring, and all wiring and connections in the primary circuit. If these parts are okay, remove coil for testing.

Distributor Cap

To test for a secondary breakdown, position the cap so that the inner segments can be seen. Turn ignition key on and crank the engine. The high voltage entering in the cap from the coil will arc across any portion that may be defective. If the cap is free from defects, check the seating of each spark plug wire and clean all surfaces.

Rotor

To test, remove the distributor cap. Remove the coil wire that leads into the cap. Hold this coil wire one-half inch above the rotor. Crank the engine with the key on; no sparks should be obtained. If the rotor is defective, the high voltage spark will pinpoint the exact location of the defect. Replace if necessary.

Point Adjustment

Adjust the breaker points as shown in the table below for appropriate model distributor you have installed.

CAUTION: In models with the triangular hole in the breaker plate, exercise care in using a screwdriver to adjust the setting, as it is possible to extend the screwdriver blade far enough to damage the

DP CURVE

All dual point distributors that end in 01 have 24° @ 3000 RPM Except:

2301105	18° @ 2000 RPM	2362901	24° @ 4000 RPM
2301106	14° @ 2500 RPM	2363301	28° @ 3000 RPM
2527501	16° @ 3600 RPM	2364001	28° @ 4600 RPM
2354109	22° @ 2500 RPM	2368301	28° @ 3000 RPM
2557901	20° @ 3000 RPM	2768902	18° @ 3400 RPM

MALLORY TUNE-UP PARTS 8 CYLINDER	25 AND 26 SERIES MECH. ADVANCE	27 SERIES VAC. ADVANCE	CONTACT POINT ADJUSTMENT	
			DUAL POINT	SINGLE POINT
DISTRIBUTOR CAP	209	209		
ROTOR	309	310	POINT GAP, .022"	POINT GAP .018"
HIGH ENERGY DISTRIBUTOR CAP	208*	208**		
HIGH ENERGY ROTOR	308	307		
PERFORMANCE POINTS	25042X			
STANDARD POINTS	25042	157	DWELL (EA.) 26°	DWELL 29°
CONDENSER	400	401		
DUAL POINT KIT (STD.)	29315	29405		
DUAL POINT/CONDENSER KIT (STD.)	29320	29406		
TUNE-UP KIT	570	-	TL DWELL 33 ± 2°	
VACUUM ADVANCE CHAMBER	-	29332		

* MUST BE BRACKET KIT PART NO. 29316

** MUST USE BRACKET KIT PART NO. 29317

MALLORY TUNE-UP PARTS 6 CYLINDER	23 AND 24 SERIES MECH. ADVANCE	25 AND 26 SERIES MECH. ADVANCE	VAC. ADVANCE	CONTACT POINT ADJUSTMENT	
				DUAL POINT	SINGLE POINT
DISTRIBUTOR CAP	270	209	209	POINT GAP .028"	POINT GAP .022"
ROTOR	309	320	310		
PERFORMANCE POINTS	25042X	25042X	-	DWELL (EA.) 29°	DWELL 31°
STANDARD POINTS	25042	25042	157		
CONDENSER	400	400	401	TL DWELL 41 ± 2°	TL DWELL 34 ± 2°
VACUUM ADVANCE CHAMBER	-	-	29332		

POINT IGNITION: 23 SERIES

SEMI-EVEN AND ODD-FIRE V6	23 SERIES	CONTACT POINT ADJUSTMENT
DISTRIBUTOR CAP	270	POINT GAP .022"
ROTOR	310	
PERFORMANCE POINTS	25042X	INDIVIDUAL DWELL 30°
STANDARD POINTS	25042	
CONDENSER	400	TL DWELL 35 ± 2°

MALLORY TUNE-UP PARTS 4 CYLINDER	23 AND 24 SERIES MECH. ADVANCE	25 AND 26 SERIES MECH. ADVANCE	27 VAC. ADVANCE	CONTACT POINT ADJUSTMENT	
				DUAL POINT	SINGLE POINT
DISTRIBUTOR CAP	271	225	271	POINT GAP .022"	POINT GAP .018"
ROTOR	309	320	310		
PERFORMANCE POINTS	25042X	25042X	-	DWELL (EA.) 32°	DWELL 34°
STANDARD POINTS	25042	25042	157		
CONDENSER	400	400	401	TL DWELL 41 ± 2°	TL DWELL 34 ± 2°
VACUUM ADVANCE CHAMBER	-	-	29332		



ADJUSTMENT PROCEDURE

YH MECHANICAL ADVANCE ASSEMBLY

NOTE: Check local laws before changing advance limit or advance rate.

The advance rate indicates how fast the advance comes in. To change the advance rate, you must change springs. An advance curve kit (Part No. 29014) is available. The kit includes a selection of springs, degree keys, and detailed instructions.

The advance limit is the total amount of advance provided by the mechanical advance.

To adjust the advance limit, loosen the adjustment screws and rotate the adjustment plate. Adjustment range is 0° to 28°.

LEFT HAND ROTATION

RIGHT HAND ROTATION

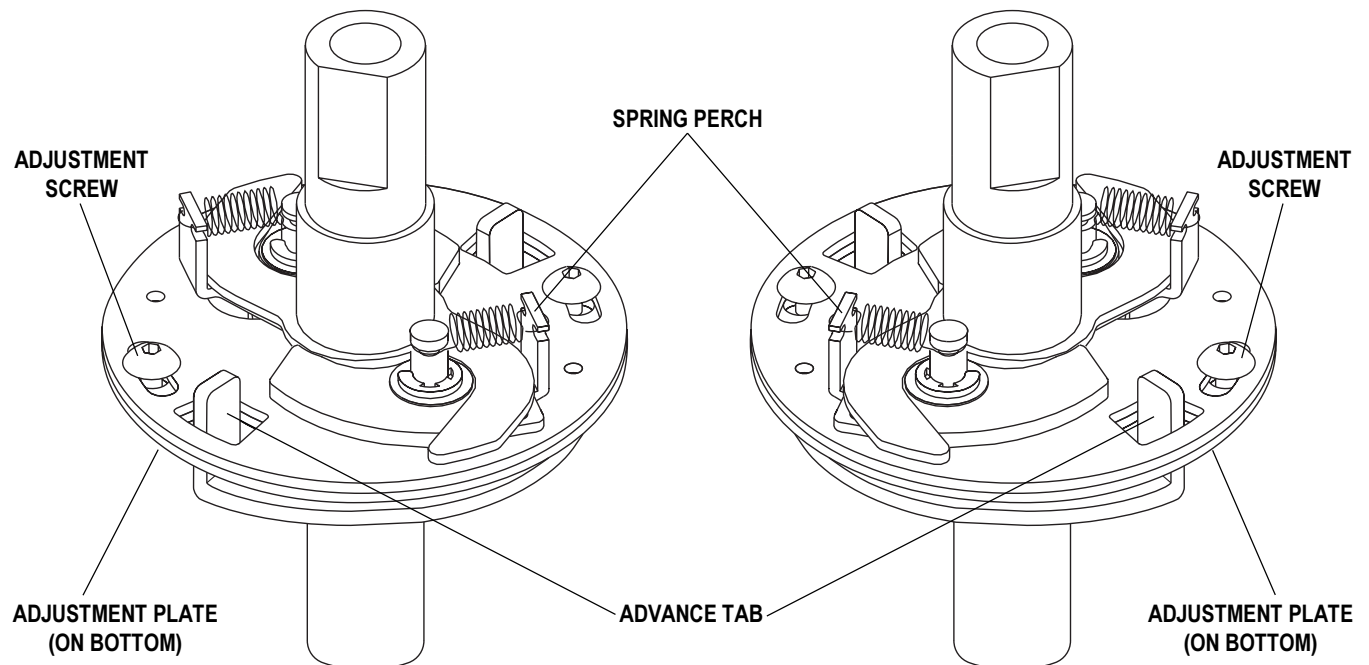

WARRANTY

To the original retail purchaser of a Mallory, Inc. product, Mallory, Inc., subject to the conditions incorporated in this Limited Warranty, warrants that its products are free from defects in material and workmanship for the period of Ninety (90) days from the date of the original retail purchase. Notwithstanding anything to the contrary herein, Mallory, Inc., subject to the conditions incorporated in this Limited Warranty, warrants that its electronic ignition products are free from defects in material and workmanship for the period of One (1) Year from the date of the original retail purchase.

This Limited Warranty will be void on all Mallory, Inc. products that have been found to have been used in racing applications of any nature whatsoever and on all Mallory, Inc. products that show evidence of abuse, lack of proper maintenance, improper installation, misapplication, alteration in any way whatsoever from their original design or negligence in the use of said Mallory, Inc. products by the original retail purchaser or by any agent of the original retail purchaser.

Mallory, Inc. expressly retains the right to make changes and improvements in any product that it manufactures and sells at any time. These changes and improvements may be made without notice at any time and without any obligation to change the catalogs or printed matter of Mallory, Inc. or to change or improve any Mallory, Inc. product previously manufactured.

Mallory, Inc. expressly retains the right to discontinue at any time and without notice any Mallory, Inc. product that it manufactures or sells.

Mallory, Inc. retains the right to determine, in its sole discretion, whether or not any Mallory, Inc. product is covered by this Limited Warranty.

To obtain warranty service, return the Mallory, Inc. product along with proof of the date of the original retail purchase, freight prepaid to: Mallory, Inc., 550 Mallory Way, Carson City, NV 89701. Because of the nature of performance vehicles and performance products, the duties and obligations of Mallory, Inc. under this Limited Warranty are expressly limited to the repair or replacement (at the discretion of Mallory, Inc.) of Mallory, Inc. products which, in the sole opinion of Mallory, Inc., have

been found to be covered under the terms and conditions of this Limited Warranty. Mallory, Inc. expressly disclaims any duty or obligation to repair or replace any product other than a Mallory, Inc. product.

This Warranty is limited and expressly excludes any incidental or consequential damages. Some states do not allow the exclusion or limitation of incidental or consequential damages, so the above limitation or exclusion may not apply to you.

This Warranty is limited and expressly limits any implied warranty to Ninety (90) days from the date of the original retail purchase on all Mallory, Inc. products except that any implied warranty on electronic ignition products is hereby expressly limited to One (1) Year from the date of the original retail purchase. Some states do not allow limitations on how long an implied warranty lasts, so the above limitation may not apply to you.

This Limited Warranty shall be for the period of Ninety (90) days from the date of the original purchase on all Mallory, Inc. products except that the warranty period for electronic ignition products shall be One (1) Year from the date of the original retail purchase and shall be nontransferable.

No person, party or corporate entity other than Mallory, Inc. shall have the right to determine whether or not this Limited Warranty is applicable to any Mallory, Inc. product or to authorize any action whatsoever under the terms and conditions of this Limited Warranty or to assume any obligation or liability of any nature whatsoever on behalf of Mallory, Inc. under the terms and conditions of this Limited Warranty.

This Limited Warranty is in lieu of and expressly excludes any and all other warranties, express or implied, including warranty of merchantability or of a fitness for a particular application or purpose.

This Warranty gives you specific legal rights, and you may also have other rights which vary from state to state.