

130837

07-10 JEEP JK FREEDOM ROOF PANEL
MOUNT KIT

**OFF CAMBER
FABRICATIONS**

by: **MBRP** INC.

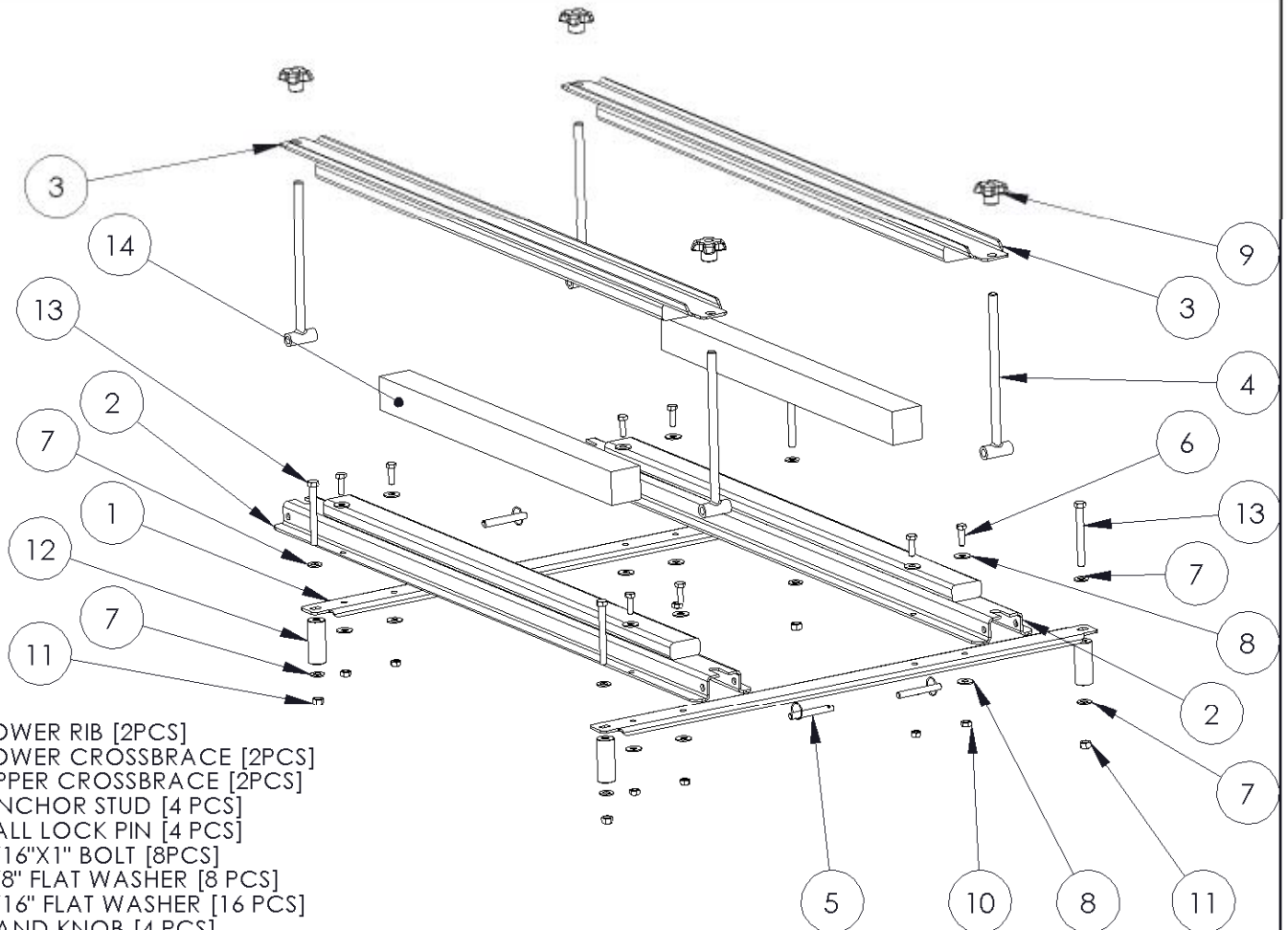

1. LOWER RIB [2PCS]
2. LOWER CROSSBRACE [2PCS]
3. UPPER CROSSBRACE [2PCS]
4. ANCHOR STUD [4 PCS]
5. BALL LOCK PIN [4 PCS]
6. 5/16"X1" BOLT [8PCS]
7. 3/8" FLAT WASHER [8 PCS]
8. 5/16" FLAT WASHER [16 PCS]
9. HAND KNOB [4 PCS]
10. 5/16" NYLOC NUT [8 PCS]
11. 3/8" NYLOC NUT [4 PCS]
12. SPACER [4 PCS]
13. 3/8"x3.5" BOLT [4 PCS]
14. FOAM [2 PCS]

PLEASE READ BEFORE STARTING INSTALLATION

While MBRP Inc. has made every effort to ensure that all components of this kit are of superior quality and properly packaged, it is the installer's responsibility to ensure the following before starting:

- that ALL components shown above are present.
- that ALL mating components fit together.
- that there are no damaged components.
- that the kit you have purchased is appropriate for your year and model of vehicle.
- that the kit will not interfere with any modifications previously installed or planned.
- that you have read and understand these instructions.

If you have any questions or are uncertain about any aspect of the installation of this kit on your vehicle please contact your dealer before commencing installation.

2007-2010 Jeep JK Freedom Roof Panel Mount Kit



Figure 1

NOTE;

This kit requires the installation of **Off Camber Fabrications** Roof Rack Kit # 130717 or # 130927 prior to installation of this **Freedom Roof Panel Mount Kit # 130837**. If you have purchased the **Cargo Basket Kit # 130822**, it must be installed prior to installation of this kit.



Figure 2

1. The Center Crossbar of the Roof Rack must be in the forward position before installing this kit. Install the two **Lower Ribs** between the Center and Rear Crossmember of the existing Roof Rack using the supplied **3/8"x3.5" Bolts, 3/8" Flat Washers, Spacers, and 3/8" Nyloc Nuts**. Make sure the hole pattern in the **Lower Ribs** is offset towards the front of the Jeep. The **Spacers** are not required if a **Cargo Basket** is not used. If you choose to not use the **Spacers**, you will have to supply suitable length bolts. **5/16"x1"** bolts will work.

Refer to Figure 1.

2. Install the two **Lower Crossbraces** across the **Lower Ribs** and secure with the supplied **5/16"x1" Bolts, 5/16" Flat Washers, and 5/16" Nyloc Nuts**. Install the **Anchor Studs** by sliding the lower end inside the **Lower Crossbrace** and securing with the supplied **Ball Lock Pins**.

Refer to Figures 2 and 3.



Figure 3

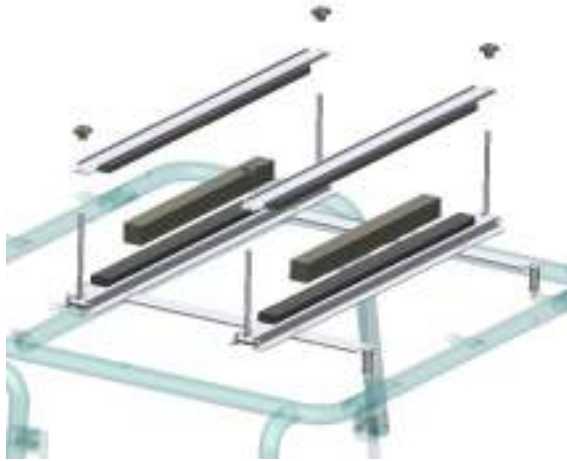

Figure 4

3. Install the **Upper Crossbraces** onto the **Anchor Studs** and install the **Hand Knobs**.
Refer to **Figure 4**.

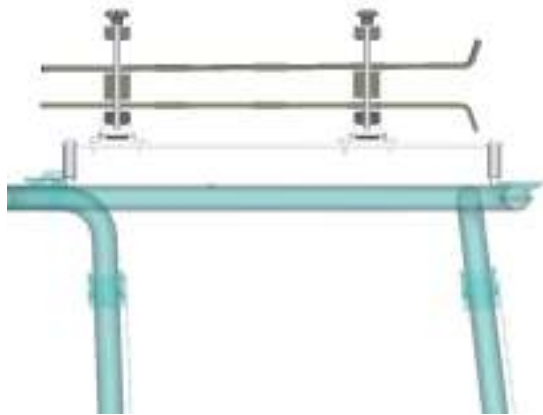

Figure 5

4. Installation of the **Roof Panels** requires that you pull the 4 **Ball Lock Pins** and remove both **Upper Crossbrace** assemblies. Lay both **Roof Panels** inside and separate them with the supplied **Foam**.
Refer to **Figure 5**.

5. Once the **Roof Panels** are in place, reinstall the **Upper Crossbrace** assemblies and secure with the **Ball Lock Pins**. Adjust the **Hand Knobs** to securely hold the **Roof Panels** in place. Once the **Hand Knobs** are tightened correctly you should be able to install/remove the **Roof Panels** by lightly compressing the **Foam** and installing/removing the **Ball Lock Pins** only.

Congratulations! You are finished. We are sure that you will enjoy this

Off Camber Fabrications product by *MBRP Inc.*