

S5052

04-07 CHEVY COLARADO
2.8L/2.9L/3.5L/3.7L, EC/CC-SB,
CAT BACK, SINGLE SIDE

MBRP

INC.

PERFORMANCE EXHAUST

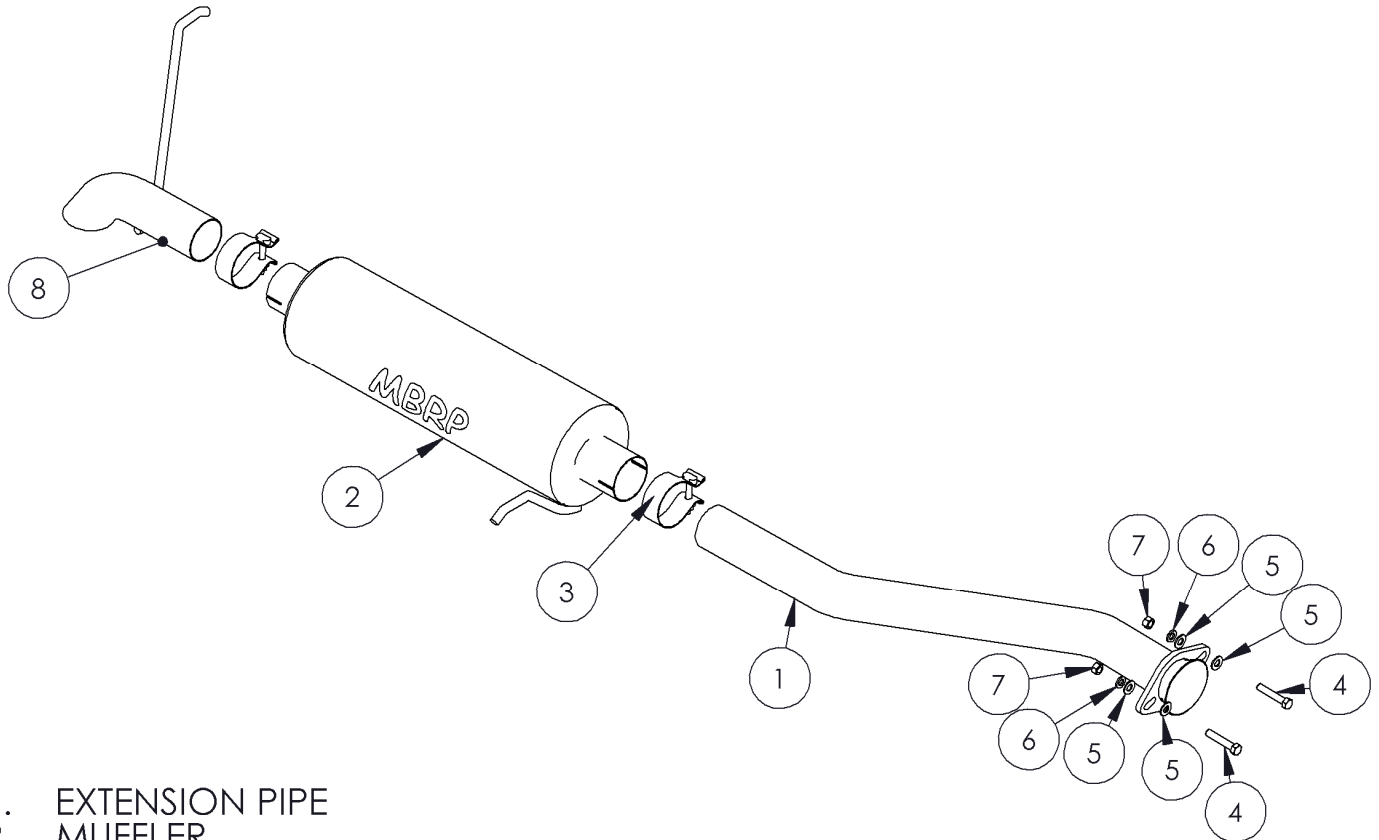

1. EXTENSION PIPE
2. MUFFLER
3. 2 1/2" BAND CLAMP (SADDLE CLAMP IN ALUMINIZED SYSTEM) (3PCS)
4. 3/8" X 2" BOLT (2PCS)
5. 3/8" WASHER (4PCS)
6. 3/8" LOCK WASHER (2PCS)
7. 3/8" NUT (2PCS)
8. EXHAUST TIP

PLEASE READ BEFORE STARTING INSTALLATION

While MBRP Inc. has made every effort to ensure that all components of this system are of superior quality and properly packaged, it is the installer's responsibility to ensure the following before removal of the factory exhaust:

- that ALL components shown above are present.
- that ALL mating components fit together.
- that there are no damaged components.
- that the system you have purchased is appropriate for your vehicle year, model and configuration.
- that the system will not interfere with any modifications previously installed or planned.
- that you have read and understand these instructions.

If you have any questions or are uncertain about any aspect of the installation of this system to your vehicle please contact your dealer before commencing installation.

2004-2008 Chev Colorado, GMC Canyon



Figure 1



Figure 2



Figure 3



Figure 4



Figure 5

Removal of stock system:

1. Apply a penetrating lubricant liberally to all exhaust fasteners, hangers and rubber insulators.
2. Cut the exhaust in front of the muffler so that it can be removed from the vehicle. **Refer to Figure 1.**
3. Remove the nuts from the studs holding the front flange together and disconnect exhaust system. **Refer to Figure 2.**
4. Remove the hangers from the rubber insulators. Remove the exhaust from the vehicle. **Refer to Figure 3.**

Installation of MBRP Inc. Performance Exhaust:

1. Install the **Extension Pipe** to the existing flange using the fasteners provided. **Refer to Figure 4.**
2. Slide a **2 ½" Clamp** over the **Extension Pipe** and install **Muffler** onto the **Extension Pipe**. Attach the **Muffler** to the existing rubber insulator. **Refer to Figure 5.**
3. Slide a **2 ½" Clamp** over the outlet side of the **Muffler**. Position the **Exhaust tip** using the existing rubber insulator and loosely attach it to the **Muffler**.
7. Align the exhaust as required. Starting at the front of the exhaust, tighten all clamps and connections.
9. Check along the whole length of the exhaust system to ensure that there is adequate clearance fuel and brake lines or any wiring. If any interference is detected relocate or adjust.

Congratulations! You are ready to begin experiencing the improved power, sound and driving experience of your MBRP Inc. performance exhaust system. We know you will enjoy your purchase.