

S5082

2014-UP CHEV/GMC 1500 SERIES,
4.3L/5.3L, CAT BACK, 2.5" SIDE EXIT DUALS,
ONE-PIECE DRIVESHAFT ONLY

MBRP
INC.
PERFORMANCE EXHAUST

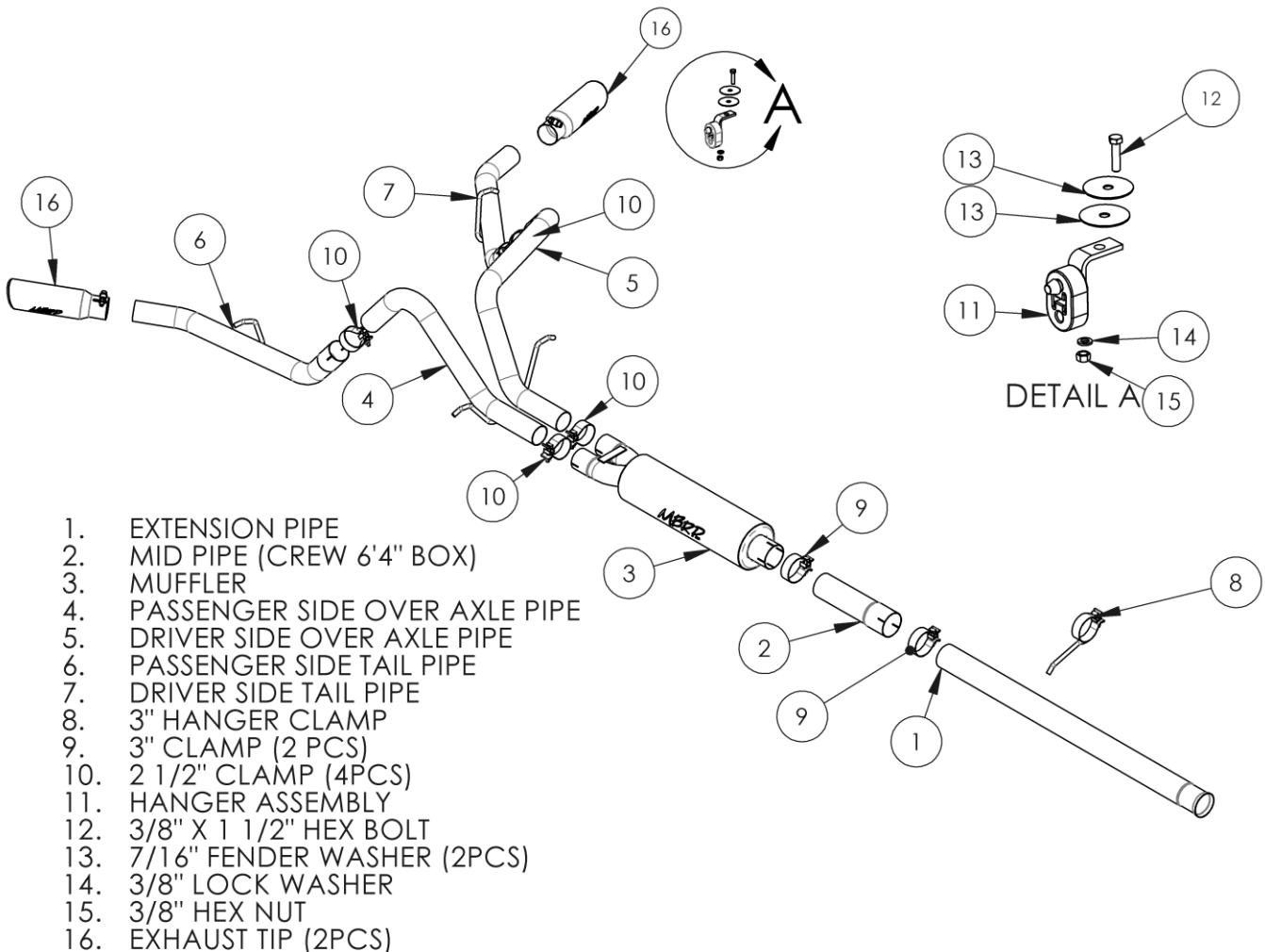

NOTE: SADDLE CLAMPS USED IN ALUMINIZED SYSTEMS

PLEASE READ BEFORE STARTING INSTALLATION

While MBRP Inc. has made every effort to ensure that all components of this system are of superior quality and properly packaged, it is the installer's responsibility to ensure the following before removal of the factory exhaust:

- that ALL components shown above are present.
- that ALL mating components fit together.
- that there are no damaged components.
- that the system you have purchased is appropriate for your vehicle year, model and configuration.
- that the system will not interfere with any modifications previously installed or planned.
- that you have read and understand these instructions.

If you have any questions or are uncertain about any aspect of the installation of this system to your vehicle please contact your dealer before commencing installation.

Removal of Stock System



Figure 1

1. Apply a penetrating lubricant liberally to all exhaust fasteners, hangers and rubber insulators.

2. Remove the clamp after the catalytic converter and save the clamp for the installation. **Refer to Figure 1.**



Figure 2

3. Remove the hangers from the rubber insulators and remove the exhaust from the vehicle. The tail pipe can be cut to ease clearing the rear axle. **Refer to Figure 2.**

4. Remove the exhaust from the vehicle.



Figure 3

Installation of MBRP Inc. Performance Exhaust

1. Install the **Extension Pipe** to the existing flange using the clamp removed earlier. Leave the hardware loose enough for some adjustment. **Refer to Figure 3.** The **Extension Pipe** will not need cutting for the Crew Cab short bed or the Extended Cab long bed. Refer to **Figure 4** for cut lengths. (**Installation tip:** Temporarily hang the **Muffler** and the **Over Axle Tail Pipe** in place and measure to the back of the Catalytic Converter to verify the length required).



Figure 5

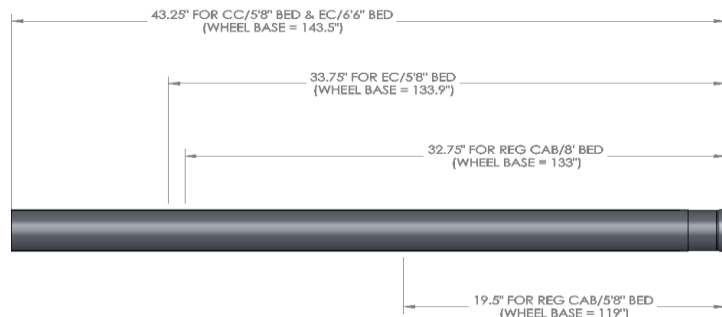

Figure 4



Figure 6

2. Slide the **3" Hanger Clamp** onto the rear of the **Extension Pipe** and into the existing rubber insulator. **Refer to Figure 5.**

3. Install the **Mid Pipe** using a **3" Clamp** if required (Crew Cab 6'4" Box).



Figure 7

4. Install **Muffler** onto the **Extension Pipe** or **Mid Pipe** using the **3" Clamp**. **Refer to Figure 6.**

5. Slide two **2 1/2" Clamps** onto the rear of the **Muffler**. Feed the **Passenger Side Over Axle Pipe** & the **Driver Side Over Axle Pipe** into the rear of the **Muffler**. Install the hangers on the **Over Axle Pipes** onto the factory rubber insulators. **Refer to Figure 7.**



Figure 8

6. Using the fasteners provided attach the **Hanger Assembly** to the bottom of the frame. The hole is located just in front of the factory trailer hitch bracket. **Refer to Figure 8.**

7. Install the **Driver Side Tail Pipe** hanger into the insulator on the **Hanger Assembly**. Secure it to the **Driver Side Over Axle Pipe** using a **2.5" Clamp**. **Refer to Figure 9.**



Figure 9



Figure 10

8. Slide the **Passenger Side Tail Pipe** hanger into the rearmost rubber insulator. Slide a **2 1/2" Clamp** onto the **Passenger Side Tail Pipe** then attach it to the **Passenger Side Over Axle Pipe**. Refer to **Figure 10**.

9. Install and adjust the **Exhaust Tips** by tightening the bolt located on each **Exhaust Tip**. Refer to **Figure 11**.

10. Align the exhaust as required before tightening the clamps. Starting at the front of the exhaust tighten all clamps and connections.



Figure 11

11. Check along the length of the exhaust system to ensure that there is adequate clearance around the spare tire, fuel and brake lines or any wiring. If any interference is detected relocate or adjust.



Congratulations! You are ready to begin experiencing the improved power, sound and driving excitement of your MBRP Inc. performance exhaust system. We know you will enjoy your purchase.