

S6024

'06-'07 CHEVY/GMC 6.6L DURAMAX,
2500/3500, 5" CAT BACK

MBRP
INC.

PERFORMANCE EXHAUST

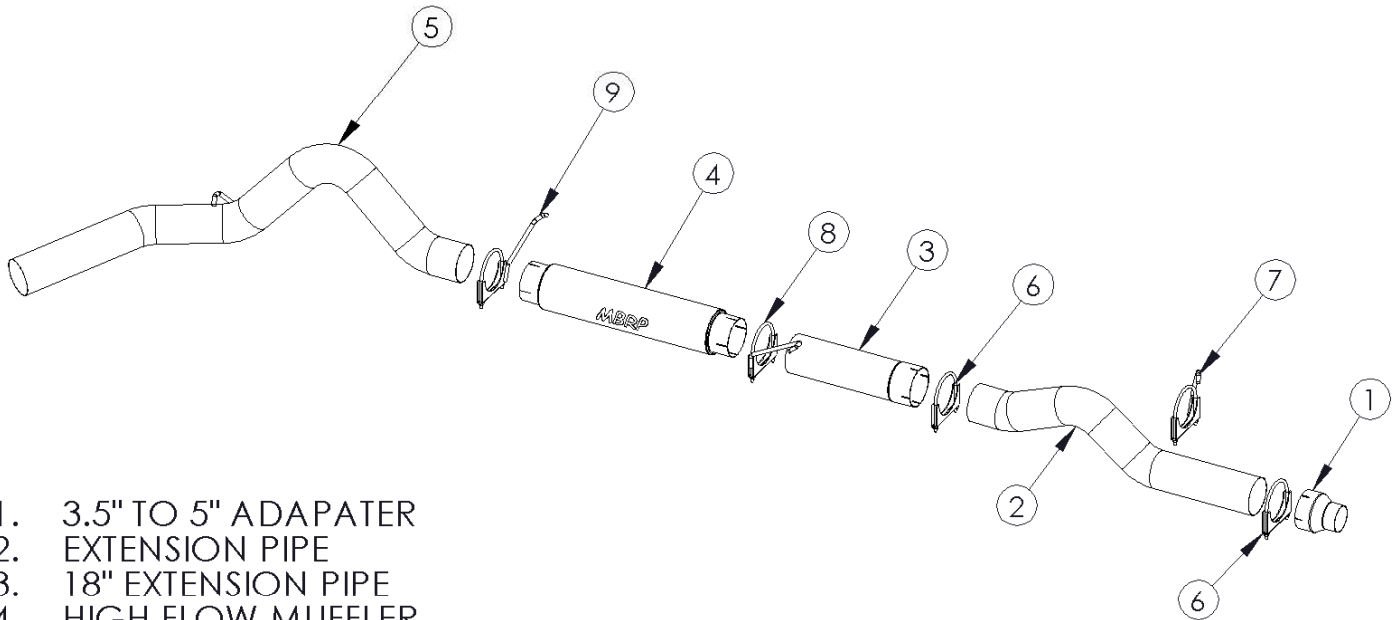

1. 3.5" TO 5" ADAPATER
2. EXTENSION PIPE
3. 18" EXTENSION PIPE
4. HIGH FLOW MUFFLER
5. TAIL PIPE
6. 5" CLAMP (2 PCS)
7. 5" HANGER CLAMP
8. 5" HANGER CLAMP
9. 5" HANGER CLAMP

PLEASE READ BEFORE STARTING INSTALATION

While MBRP Inc. has made every effort to ensure that all components of this system are of superior quality and properly packaged it is the installer's responsibility to ensure the following before removal of the factory exhaust:

- that ALL components shown above are present.
- that ALL mating components fit together.
- that there are no damaged components.
- that the system you have purchased is appropriate for your vehicle year, model and configuration.
- that the system will not interfere with any modifications previously installed or planned.
- that you have read and understand these instructions.

If you have any questions or are uncertain about any aspect of the installation of this system to your vehicle please contact your dealer before commencing installation.

Removal of stock system:

1. Apply a penetrating lubricant liberally to all exhaust fasteners, hangers and rubber insulators.
2. Loosen the band clamp located behind the catalytic converter and disconnect the factory exhaust system.
3. Remove the exhaust system from the rubber insulators and remove from under the vehicle. If a hoist is not available for use, it may be necessary to cut the tail pipe behind the muffler for removal of the system.
4. Remove the spare tire. You may not be able to reinstall your spare tire after the installation of this exhaust system.

Installation of MBRP Inc. Performance Exhaust:

1. Place the **3.5" to 5" Adapter** into the factory band clamp located behind the catalytic converter.
2. Connect the **Mid Pipe** to the **3.5" to 5" Adapter** at the slip joint placing the bend around and under the cross member. The **Mid Pipe** does not require cutting to fit crew cab trucks. For extended cab trucks, approximately 9½" needs to be cut off the end with the longest straight section of pipe.
Installation tip: Temporarily hang the **Muffler** and the **Tail Pipe** in place and measure to the **Adapter** to verify the length required.
3. Rotate the **Mid Pipe** toward the drive shaft and loosely install the **Hanger Clamp** with the shortest hanger. This will support the Extension Pipe during the **Muffler** installation.
4. Crew cab & extended cab long bed trucks require the use of the **18" Extension Pipe** provided. This is to be positioned between the **Muffler** and the **Mid Pipe**. The **18" Extension Pipe** is not required with short bed trucks.

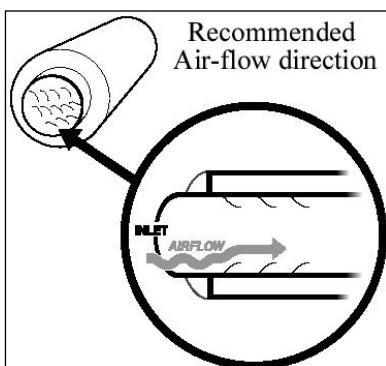

5. Install the **Muffler** over the required pipe so that the exhaust will flow smoothly over the louvers. Refer to the illustration on the left.
6. Install the **Hanger Clamp** into the OEM rubber hanger located on the frame above the inlet of the **Muffler**.
7. Install the **Tail Pipe** from the rear of the truck, over the axle and attach to the **Muffler** outlet. To complete install the tail pipe hanger into the OEM hanger and adjust for best axle clearance and **Tail Pipe** exit location.
8. Install the **Hanger Clamp** into the OEM rubber hanger located above the outlet of the **Muffler**.
9. Install the provided clamps around the pipes where needed. Adjust the **Tail Pipe** and check along the whole length of the exhaust system to ensure that there is adequate clearance around the fuel and brake lines or any wiring. If any interference is detected relocate or adjust.



10. Make sure the exhaust is in place before tightening the clamps. Start at the front of the exhaust system and begin tightening all connections.
11. If a tip has been purchased, install and adjust to suit. Using a 17mm wrench tighten the lock bolt located on the **Tip. A Tip is not included with this kit.** Tips may be purchased separately, check with your dealer.

Congratulations! You are ready to begin enjoying the improved performance and driving experience of your MBRP Inc. performance exhaust system. We hope you enjoy your purchase.

