

S6116PLM/S6116SLM

04.5-07 DODGE 5.9L CUMMINS 600/610, 2500/3500, 5" TURBO BACK, SINGLE, OFF ROAD

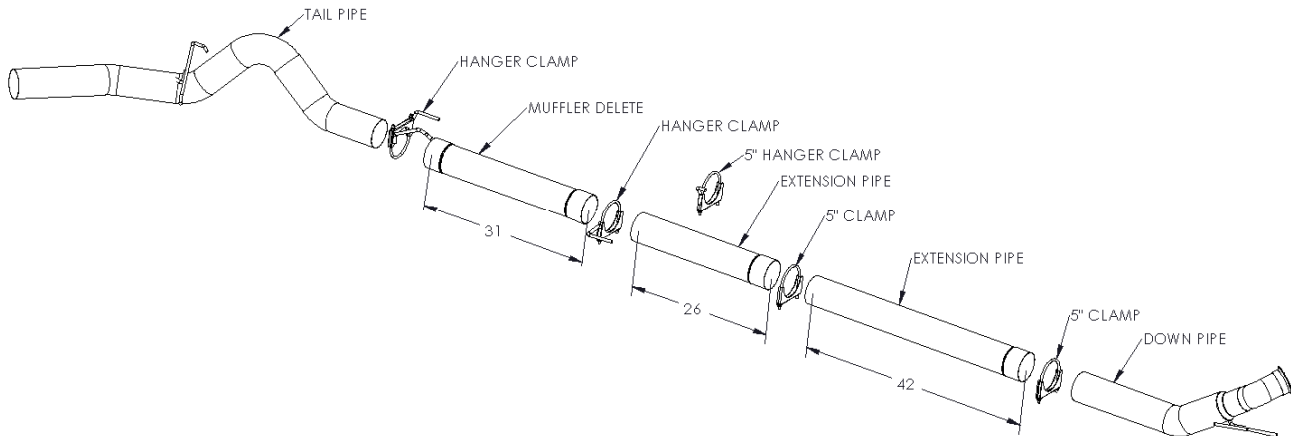

November 2, 2010



PLEASE READ BEFORE STARTING INSTALLATION

MBRP Inc. has made every effort to ensure that all components of this system are of superior quality and properly packaged. It is the installer's responsibility to ensure that all components are present and fit together as shown. Please also ensure that all components are undamaged before removal of the factory exhaust. Finally, check that this system properly matches the make and model of the vehicle and will not interfere with previous or planned modifications.

Removal of Stock System:

1. Apply a penetrating lubricant liberally to all exhaust fasteners, hangers and rubber insulators.
2. Remove the exhaust system from the rubber insulators and remove all of the clamps from the system.
3. Separate the slip joint behind the muffler and remove the tail pipe. Next, separate the slip joint connecting the down pipe and the extension pipe to remove the muffler and extension pipe. Finally loosen the band clamp connecting the down pipe to the turbo and remove the down pipe. **Do not discard the band clamp as it is required for the installation.**
4. Remove the OEM down pipe hanger bracket from the bellhousing. Do not discard these parts as they are required for the installation.

Installation of MBRP Inc. Performance Exhaust:

1. Slide the OEM down pipe hanger bracket onto the Down Pipe hanger. Install the Down Pipe in the same position as the stock down pipe by reattaching the hanger bracket to the bellhousing and then attaching the flared end to the turbo using the stock band clamp. Do not fully tighten until all components are in place.
2. Install the Extension Pipe 42" onto the Down Pipe and then the Extension Pipe 26" onto the Extension Pipe 42". The combination of the both Extension Pipes provides the required length to fit a Quad Cab Long Bed truck or Mega Cab. These pipes will have to be cut to fit all other vehicles. Installation Tip: Temporarily install the Muffler Delete and Tail Pipe using the factory rubber insulators and the Hanger Clamp. Measure from the Muffler Delete to the Mid Pipe to determine the length required. Cut the pipe to the required length.
3. Install the Muffler Delete over the Extension Pipe and the Hanger Clamps into OEM rubber hangers refer to the illustration.
4. Install the Tail Pipe from the rear of the truck, over the axle and attach to the outlet of the Muffler Delete. Install the hanger on the Tail Pipe to the existing OEM rubber hanger.
5. Install the provided Clamps around the pipes where required. Adjust the Tail Pipe and check along the whole length of the exhaust system to ensure there is adequate clearance around the fuel and brake lines or any wiring. If any interference is detected relocate or adjust.
6. Start at the front of the exhaust system and begin tightening all connections. Recheck for interference after tightening and adjust if required.

PLEASE NOTE: This system is designed for off-road use only. If highway operation is intended please consult your local or state authority for more information.

Congratulations! You are ready to begin experiencing the improved performance and driving excitement of your MBRP Inc. performance exhaust system. We know you will enjoy your purchase.