

S6134

**2010 DODGE 2500/3500 6.7L CUMMINS,
PARTICULATE FILTER BACK, 5" SINGLE SIDE**

MBRP
INC.

PERFORMANCE EXHAUST

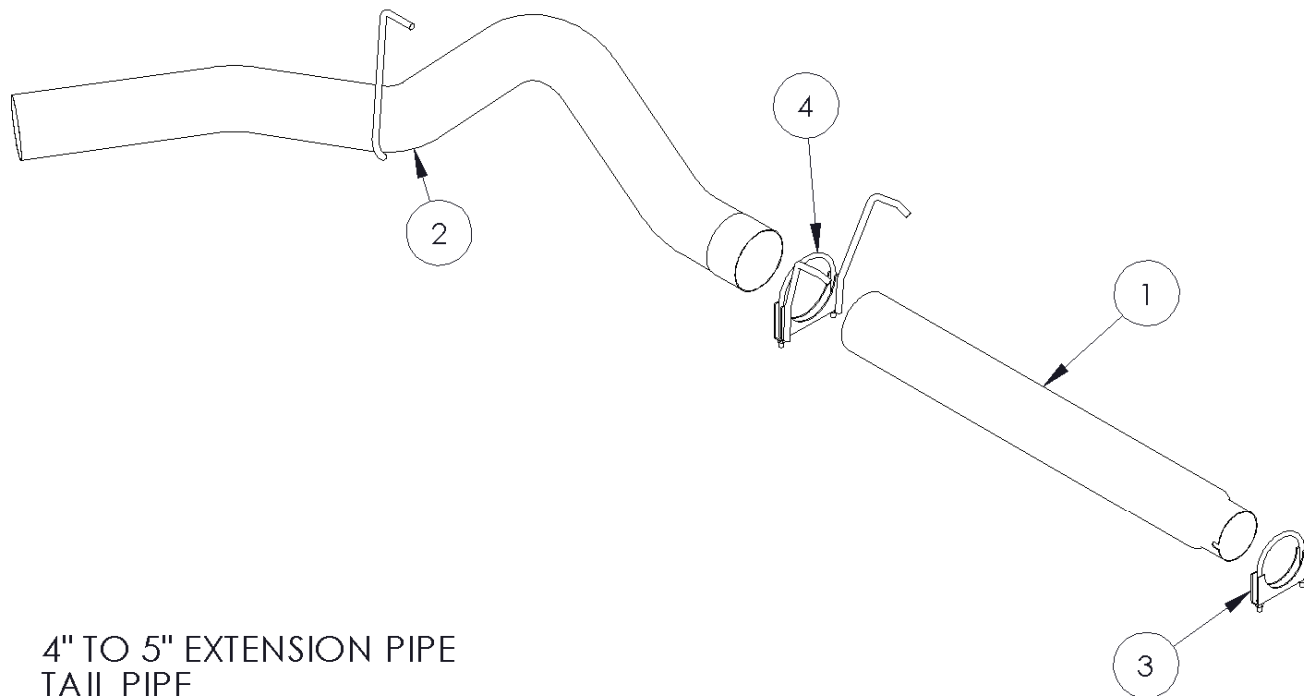

1. 4" TO 5" EXTENSION PIPE
2. TAIL PIPE
3. 4" CLAMP
4. 5" HANGER CLAMP

PLEASE READ BEFORE STARTING INSTALATION

While MBRP Inc. has made every effort to ensure that all components of this system are of superior quality and properly packaged, it is the installer's responsibility to ensure the following before removal of the factory exhaust:

- that ALL components shown above are present.
- that ALL mating components fit together.
- that there are no damaged components.
- that the system you have purchased is appropriate for your vehicle year, model and configuration.
- that the system will not interfere with any modifications previously installed or planned.
- that you have read and understand these instructions.

If you have any questions or are uncertain about any aspect of the installation of this system to your vehicle please contact your dealer before commencing installation.

2010 DODGE 6.7L Cummins, 2500/3500

Removal of Stock System:

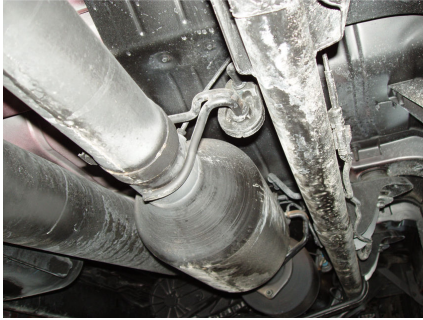

Figure 1

1. Apply a penetrating lubricant liberally to all exhaust fasteners, hangers and rubber insulators.



Figure 2

2. Loosen the nut on the clamps located behind the particulate filter and behind the muffler using a 15mm wrench or socket. **Refer to Figure 1.**

3. Remove the muffler and tail pipe from the OEM rubber hangers. Remove the stock exhaust from vehicle. **Refer to Figure 2.**

Installation of MBRP Inc. Performance Exhaust:

1. The **4" to 5" Extension Pipe** provided is the length used for the Crew Cab Long bed. For all other models the **Extension Pipe** must be cut. **Refer to Figures 3 & 4.**



Figure 3

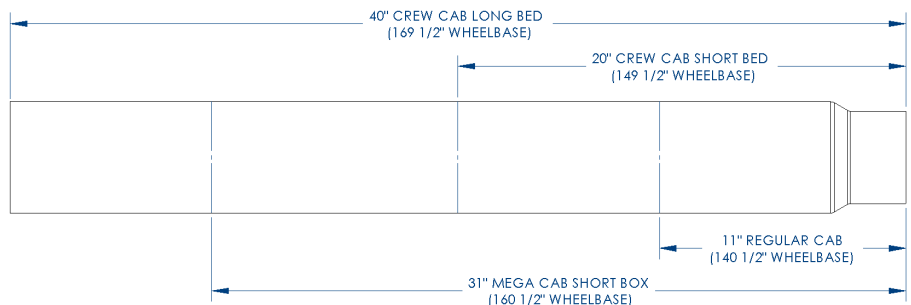

Figure 4



Figure 5

2. Slide the **5" Hanger Clamp** onto the outlet end of the **4" to 5" Extension Pipe**. Install the hangers into the existing OEM rubber insulators. **Refer to Figure 5.**

3. Install the **Tail Pipe** from the rear of the truck, over the axle and attach to the **4" to 5" Extension Pipe** using the **5" Hanger Clamp**. Slide the **Tail Pipe** hanger into the OEM rubber insulator. **Refer to Figure 6.**



Figure 6

4. Align the exhaust as required. Starting at the front of the exhaust, tighten all clamps and connections.

5. Check along the whole length of the exhaust system to ensure that there is adequate clearance around the spare tire, fuel and brake lines or any wiring. If any interference is detected relocate or adjust.



Congratulations! You are ready to begin experiencing the improved power, sound and driving experience of your MBRP Inc. performance exhaust system. We hope you enjoy your purchase.