

S8006

'01-'07 CHEVY/GMC DURAMAX, DOWN
PIPE BACK, SMOKERS™ SINGLE (EXCLUDES
LMM)

MBRP

INC.

PERFORMANCE EXHAUST

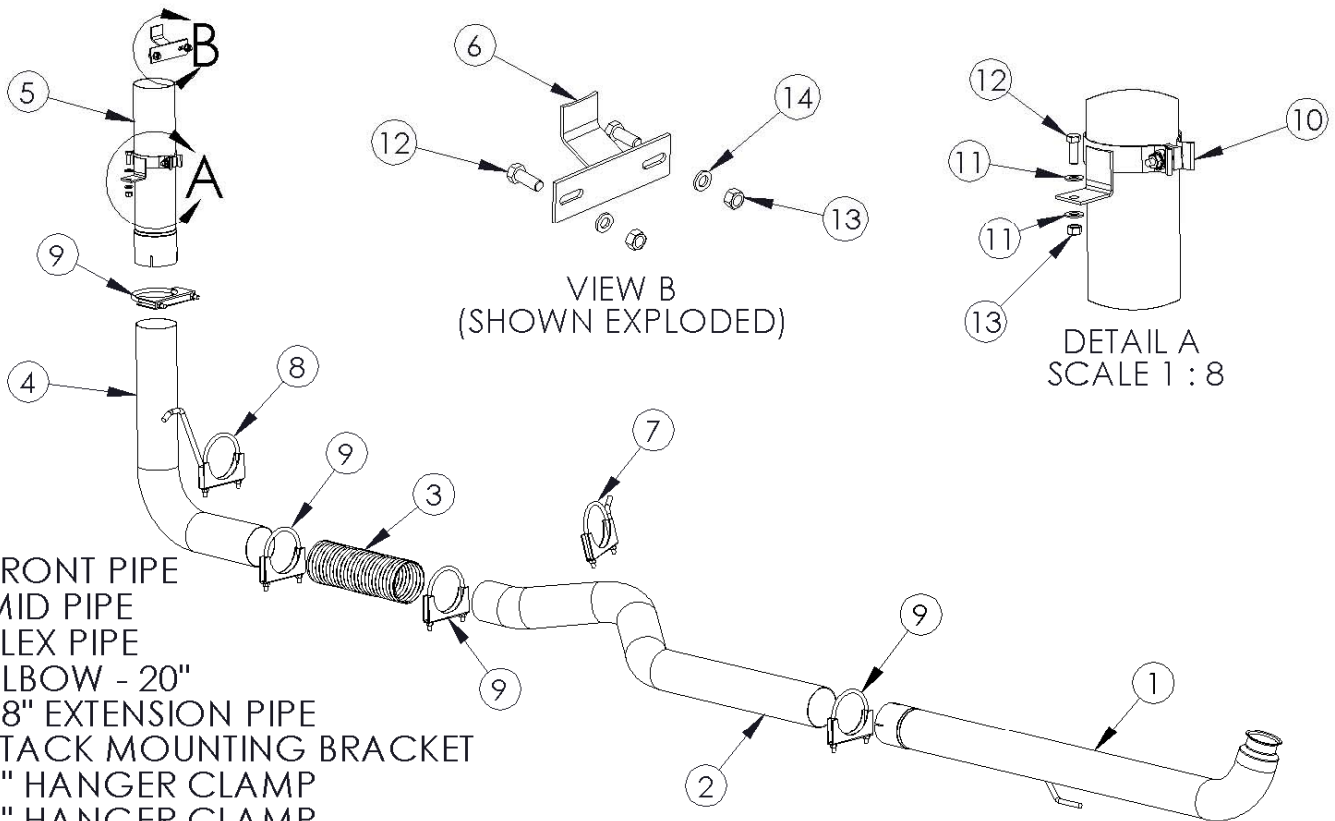

1. FRONT PIPE
2. MID PIPE
3. FLEX PIPE
4. ELBOW - 20"
5. 18" EXTENSION PIPE
6. STACK MOUNTING BRACKET
7. 4" HANGER CLAMP
8. 4" HANGER CLAMP
9. 4" CLAMP (4 PCS)
10. BED MOUNTING BRACKET
11. 3/8" WASHER (2 PCS)
12. 3/8" BOLT (3 PCS)
13. 3/8" NUT (3 PCS)
14. 3/8" LOCK WASHER (2 PCS)

NOTE: STACK SOLD SEPARATELY

PLEASE READ BEFORE STARTING INSTALLATION

While MBRP Inc. has made every effort to ensure that all components of this system are of superior quality and properly packaged it is the installer's responsibility to ensure the following before removal of the factory exhaust:

- that ALL components shown above are present.
- that ALL mating components fit together.
- that there are no damaged components.
- that the system you have purchased is appropriate for your vehicle year, model and configuration.
- that the system will not interfere with any modifications previously installed or planned.
- that you have read and understand these instructions.

If you have any questions or are uncertain about any aspect of the installation of this system to your vehicle please contact your dealer before commencing installation.

Removal of Stock System:



Figure 1



Figure 2



Figure 3



Figure 4

1. Apply a penetrating lubricant liberally to all exhaust fasteners, hangers and rubber insulators.
2. For 2001-2005 vehicles use a 15mm socket or wrench and disconnect the factory exhaust system at the four bolt flange located behind the Catalytic Converter. **Refer to Figure 1.** If the vehicle is not equipped with a Catalytic Converter disconnect the four bolt flange located approximately under the passenger side seat. For 2006 & 2007 vehicles loosen the Band Clamp located behind the Catalytic Converter.
3. Remove the exhaust system from the rubber insulators and remove from under the vehicle. If a hoist is not available for use, it may be necessary to cut the tail pipe behind the muffler for removal of the system.
4. Unbolt the OEM hanger for the front pipe from the transmission and remove. **Do not discard the hanger as it is required for the installation. Refer to Figure 2.**
5. Loosen the factory band clamp and remove the stock front pipe. **Refer to Figure 3. Do not discard the band clamp as it is required for the installation.**

Installation of MBRP Inc. "Smokers"TM:

1. Install the **Front Pipe** onto the factory down pipe using the band clamp removed previously. Do not fully tighten to allow for adjustment. **Refer to Figure 4.**
2. Install the hanger removed previously by sliding the outside hole in the rubber insulator over the hanger on the **Front Pipe** and re-connect to the transmission.
3. Connect the **Mid Pipe** to the **Front Pipe** at the slip joint placing the bend under the cross member. The **Mid Pipe** does not require cutting to fit Crew Cab trucks. For Extended Cab trucks, approximately 9 1/2" needs to be cut off the end with the longest straight section of pipe.

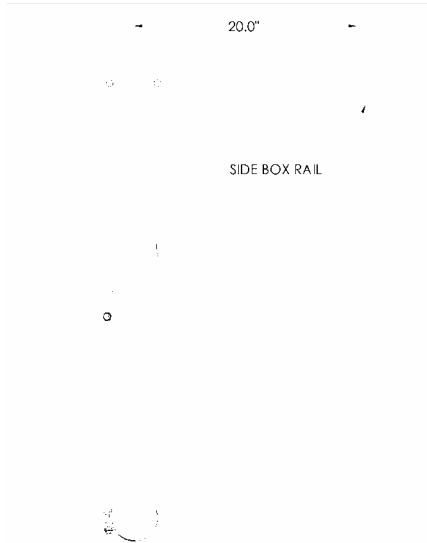

Figure 5

4. Measure 20" across from the inside surface of the passenger side bed rail. Mark this location along the rail. This will be the approximate centerline of the **Stack** once installed. **Refer to Figure 5.**

5. Slide the **Band Clamp** (from **Stack** kit – purchased separately) over the **Stack**. Wedge the **Stack Mounting Bracket** between the **Band Clamp** and the **Stack**. Adjust to the bed rail height and tighten the **Band Clamp** slightly. Make sure the **Stack** is vertical, the **Stack Mounting Bracket** is flush against the bed rail and centered on the measurement made in Step 4. Trace a circle around the base of the **Stack** and center punch the circle's center. Verify that the center punch hole is in line with the Mid Pipe and adjust accordingly. This will be the center line of your **Stack**.



Figure 6

6. Align the **Stack** centered on the mark you made in **Step 5**. Mark the bolt hole location of the **Stack Mounting Bracket** onto the front rail of the bed. Center punch the marks and drill holes to accommodate the **3/8"** hardware (supplied with the **Stack Mounting Bracket**). **Refer to Figure 6.**



Figure 7

7. Loosely attach the **Stack Mounting Bracket** to the front of the truck bed using the **3/8"** hardware supplied. Set the **Stack** up in the bed and loosely attach it to the **Stack Mounting Bracket**. Make sure the **Stack** is vertical and in the desired position. **Refer to Figure 7.**

8. Confirm the base of the **Stack** is resting in the same position as in Step 5. Re-trace and center punch if needed. This is where the **18" Extension Pipe** will pass through the floor. Remove the **Stack** from the bed of the truck. Drill the hole using a 5" hole saw. It may be required to cut part of a bed floor rail away. **Refer to Figure 8.**



Figure 8



Figure 9



Figure 10

9. Measure from the **Extension Pipe** slip joint to the **Mid Pipe**. Mark and cut the shorter side of the **Elbow** to the required length so that it lines up with the **Mid Pipe**. Cut the vehicle's exhaust system in a place where the **Flex Pipe** can be placed between the **Mid Pipe** and the **Elbow**. It may be necessary to cut the **Elbow** again as well as cut the **Flex Pipe** to ensure proper fit. **Refer to Figure 9.**
10. Attach the **Elbow** to the **Extension Pipe** slip joint and then attach the **Flex Pipe** to both the **Elbow** and the **Mid Pipe**. Be sure to slide the required **Clamps** over the **Elbow** and **Flex Pipe** before connecting it to the **Mid Pipe**. **Refer to Figure 10.**
11. Slide the **Bed Mounting Bracket** onto the **Extension Pipe**. Install the assembly on the outlet of the **Elbow** with the required **Clamp**. Reinstall the **Stack** by sliding the inlet over the **Extension Pipe** and then securing the **Stack** to the **Stack Mounting Bracket** with the **Clamp** supplied with your **Stack**. Align the system and tighten all **Clamps** to ensure that your "Smokers™" exhaust remains properly aligned.
12. Slide the **Bed Mounting Bracket** to the desired position on the **Extension Pipe** to allow installation of the mounting hardware. Ensure the **Stack** is vertical. Trace the **Bed Mounting Bracket** hole from the bracket onto the bed floor and drill a hole to accommodate the **3/8"** hardware supplied. Secure the **Bed Mounting Bracket** to the truck and tighten the **Clamp** to the **Extension Pipe**. This **Bed Mounting Bracket** will ensure the **Stack** remains in position and doesn't vibrate.
13. Check along the whole length of the exhaust system to ensure that there is adequate clearance around the fuel lines, brake lines and any wiring. If any interference is detected relocate or adjust.



Shown with 6" x 36" Stack (B1610)

Congratulations! You are ready to begin experiencing the improved power, sound and driving excitement of your MBRP Inc. "Smokers™". We know you will enjoy your purchase.