

# S8010

2011 CHEVROLET/GMC, 2500/3500 HD,  
DURAMAX, EXTENDED CAB LONG  
BED/CREW CAB LONG BED,PARTICULATE  
FILTER BACK SMOKERS

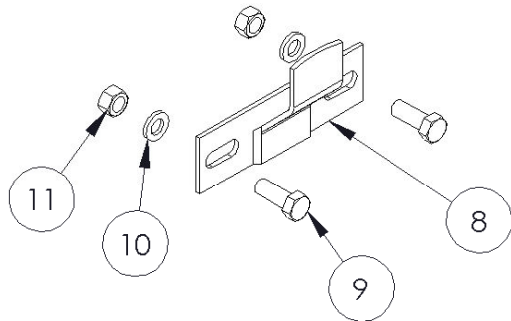

DETAIL A  
(SHOWN EXPLODED)

1. FLEX PIPE
2. LOWER PIPE
3. T-PIPE
4. ELBOW 37"
5. ELBOW 13"
6. 4" BAND CLAMP (2PCS)
7. 4" CLAMP (3PCS)
8. STACK MOUNTING BRACKET
9. 3/8" HEX BOLT (4PCS)
10. 3/8" LOCK WASHER (4PCS)
11. 3/8" HEX NUT (4PCS)

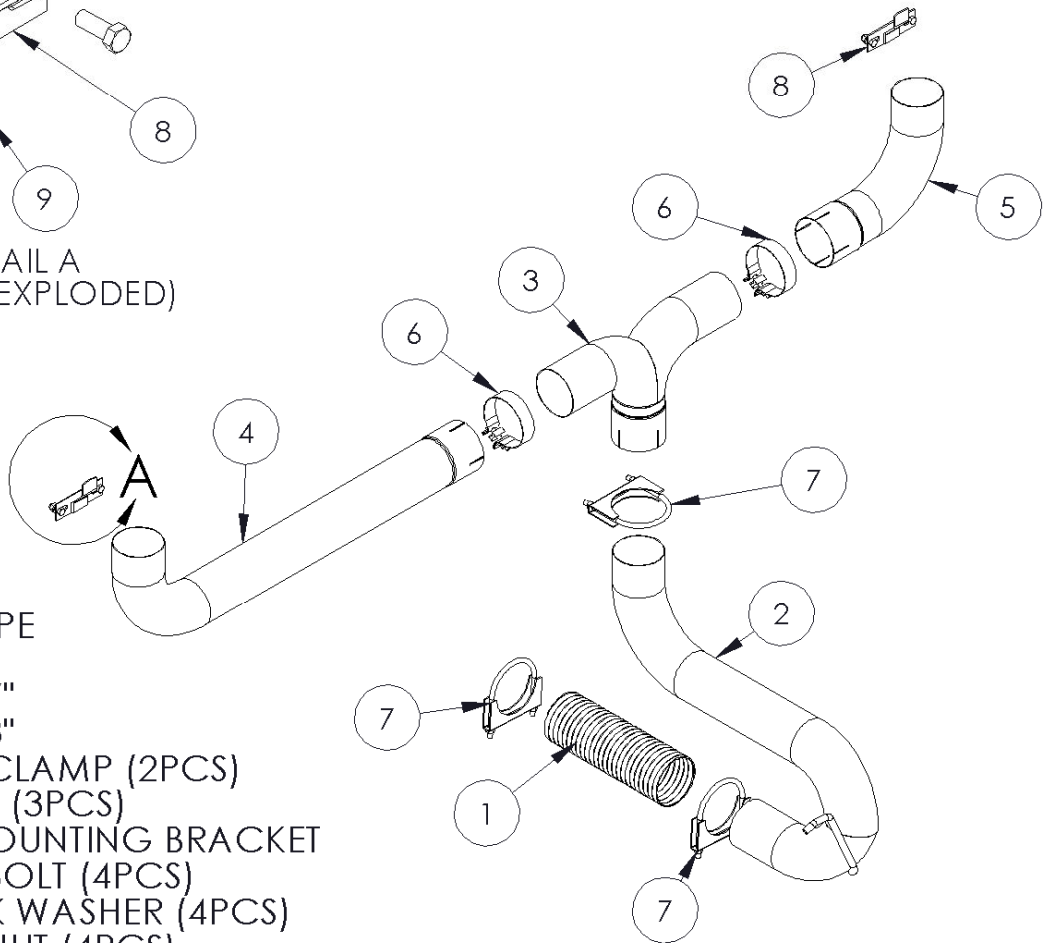

## PLEASE READ BEFORE STARTING INSTALLATION

While MBRP Inc. has made every effort to ensure that all components of this system are of superior quality and properly packaged, it is the installer's responsibility to ensure the following before removal of the factory exhaust:

- that ALL components shown above are present.
- that ALL mating components fit together.
- that there are no damaged components.
- that the system you have purchased is appropriate for your vehicle year, model and configuration.
- that the system will not interfere with any modifications previously installed or planned.
- that you have read and understand these instructions.

If you have any questions or are uncertain about any aspect of the installation of this system to your vehicle please contact your dealer before commencing installation.

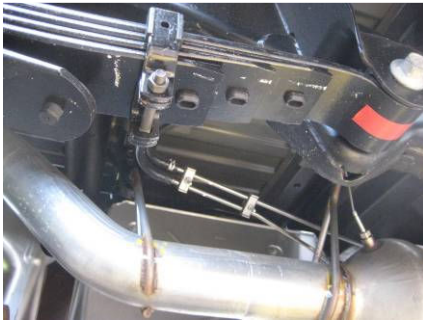

**Figure 1**



**Figure 2**

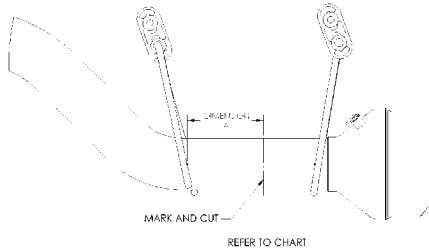

**Figure 3**



**Figure 4**

### Removal of Stock System:

1. Apply a penetrating lubricant liberally to all exhaust fasteners, hangers and rubber isolators.
2. Refer to the illustration in **Figure 3** and the chart below to determine where to cut the existing exhaust rear of the particulate filter.

Cab Style	Box Style	Wheelbase	Dimension A	Extension Pipe Cut Length
CREW	8' 2"	167.7"	12.5"	21"
EXTENDED	8' 2"	157.7"	12.5	21"

3. Remove the factory tail pipe assembly from the factory rubber isolators. Remove the tail section from the vehicle. **Refer to Figures 1 & 2.**

### Installation of MBRP Inc. Performance Exhaust:

1. Loosely assemble the in bed portion of the **T-Pipe Assembly (T-Pipe, 13" Elbow and 37" Elbow)**. Some models may require trimming of the **T-Pipe** in order to accommodate the width of the truck bed and the Stacks that have been purchased. Be sure to place the **4" Band Clamps** over the pieces before they are assembled. **Refer to Figure 4.**
2. Place the Stacks onto the **T-Pipe Assembly** and place into the desired position in the truck bed. The **37" Elbow** should be on the driver side so that the **T-Pipe** passes through the bed floor towards the passenger side. **Refer to Figures 4 & 5.**



Figure 5



Figure 6



Figure 7



Figure 8

3. Place the **Stack Mounting Brackets** between each Stack and the front of the truck bed so that the Stacks are properly spaced from the front of the truck bed. Center the **Stack Mounting Brackets** on the Stacks and mark the front of the truck bed in the center of the slotted holes in the **Stack Mounting Brackets**. Center punch the marks and drill holes to accommodate the **3/8" Bolts** (included with the **Stack Mounting Brackets**). Refer to **Figure 5**.
4. Loosely attach the **Stack Mounting Brackets** to the front of the truck bed using the **3/8"** hardware supplied. Set the Stacks up in the bed and loosely attach them to the **Stack Mounting Brackets**. Make sure the Stacks are in the desired position and the **T-Pipe Assembly** is level.
5. Mark the bed floor where the **T-Pipe** is resting. MBRP Inc. recommends tracing around where the **T-Pipe** meets the floor. Refer to **Figure 6**. Remove the Stacks and **T-Pipe Assembly** from the bed of the truck. Find the center of the circle traced onto the bed floor, mark and center punch it. Go under the vehicle and locate the center punch mark. This marks the location where you are going to cut a hole for the **T-Pipe** to pass through the bed of the truck. If you cannot find the center punch mark use a small drill to create a pilot hole. Make sure that there is clearance for the **Lower Pipe** to pass by any frame cross members. Modify any heat shields that may cause interference.
6. Cut a hole through the truck bed providing adequate clearance around the part of the **T-Pipe** that passes through the truck bed. MBRP Inc. recommends using a **5"** diameter hole saw. It may be required to cut away part of a bed rail. Refer to **Figure 7**.
7. Set the **T-Pipe Assembly** at the desired height from the floor of the bed (This will set the height of the Stacks). Using spacers to hold the **T-Pipe** at the desired height, loosely attach the Stacks to the **Stack Mounting Brackets** making sure that they are straight. This will hold the assembly steady while you line up to the exhaust under the vehicle. Refer to **Figure 8**.



**Figure 9**

8. Pre-install the **Flex Pipe** onto the **Lower Pipe**. Install the assembly from onto the vehicle by inserting the outlet of the **Lower Pipe** into the inlet of the **T-Pipe**. Install the hanger into the factory rubber isolator. Slide the **Flex Pipe** onto the outlet of the DPF. **Refer to Figure 9.**

9. Relocate the bracket and hoses and reposition so the lines do not interfere with the exhaust. **Refer to Figure 10.** Check along the full length of the exhaust system to ensure there is adequate clearance for fuel lines, break lines, and any wiring, etc. If any interference is detected, relocate or adjust to provide adequate clearance.



**Figure 10**

10. Make sure the **Stack Mounting Brackets** are centered on the Stacks and tighten the fasteners holding the **Stack Mounting Brackets** to the front of the truck bed. Tighten all **Clamps** to ensure your "Smokers™" exhaust system remains properly aligned.

**Congratulations!** You are ready to begin experiencing the improved driving pleasure of your MBRP Inc. "Smokers™". We know you will enjoy your purchase.

