



INSTALLATION INSTRUCTIONS FOR PART 95-2004

APPLICATIONS

Cadillac

1997-2001 Catera

1996-1999 Deville (Column Shift Only)

95-2004



KIT FEATURES

- DDIN Head Unit Provision
- ISO Stacked Head Unit Provision

KIT COMPONENTS

- (A) DDIN Brackets
- (B) DDIN Trim Plate
- (C) (4) Speed Clips
- (4) Phillips Head Screws

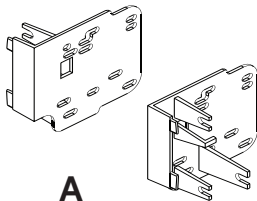

A

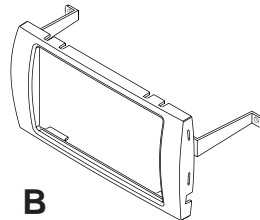

B

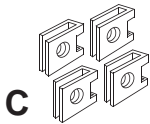

C



D

WIRING AND ANTENNA CONNECTIONS (Sold Separately)

HARNESS:

- GMRC-03 - 1997-2002 Cadillac Interface W/O Onstar
- GMOS-06 - 1997-2002 Cadillac Interface W/ Onstar

ANTENNA ADAPTER:

- 40-GM10 - GM Antenna Adapter

TOOLS REQUIRED:

- Phillips Screwdriver
- Panel Removal Tool
- Small Flat Blade Screwdriver
- Cutting Tool



METRA. THE WORLD'S BEST KITS.™



1-800-221-0932



www.metraonline.com

© COPYRIGHT 2004 METRA ELECTRONICS CORPORATION

TABLE OF CONTENTS

Dash Disassembly

1997-2001 Cadillac Catera	1
1996-1999 Cadillac Deville (Column Shift Only)	1

Kit Preparation

1997-2001 Cadillac Catera	2
1996-1999 Cadillac Deville (Column Shift Only)	2

Kit Assembly

1997-2001 Cadillac Catera / 1996-1999 Cadillac Deville (Column Shift Only)	
DDIN Head Unit Provision	3
ISO Stacked Head Unit Provision	3



KNOWLEDGE IS POWER

Enhance your installation and fabrication skills by enrolling in the most recognized and respected mobile electronics school in our industry. Log onto www.installerinstitute.com or call 800-354-6782 for more information and take steps toward a better tomorrow.



Metra recommends using MECP certified technicians.

1997-2001 CADILLAC CATERA

- 1 Disconnect the negative battery terminal to prevent an accidental short circuit.
- 2 Remove (1) Phillips head screw from inside the ashtray and remove ashtray. (Figure A)
- 3 Remove screw covers from the radio trim panel. Remove traction control and hazard switch covers. Then remove switches by depressing tabs and pulling outward. (Figure B)
- 4 Remove (4) Phillips head screws from behind covers and ashtray.
- 5 Remove radio trim panel and unplug any remaining harnesses from the panel. (Figure C)
- 6 Remove (2) Phillips head screws securing the radio. Unplug and remove the radio.

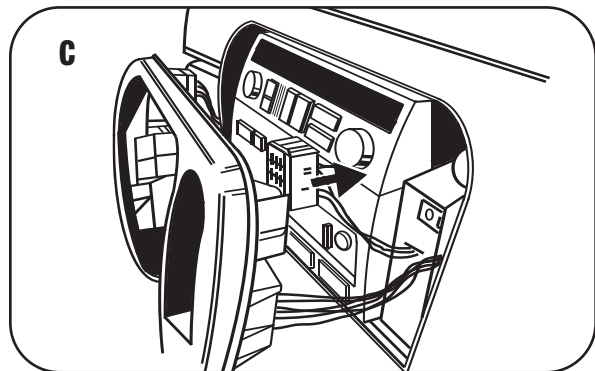
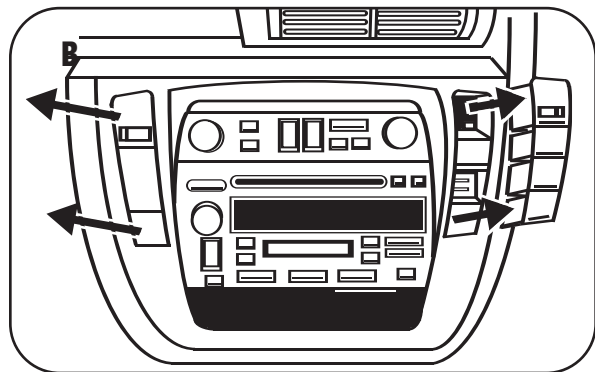
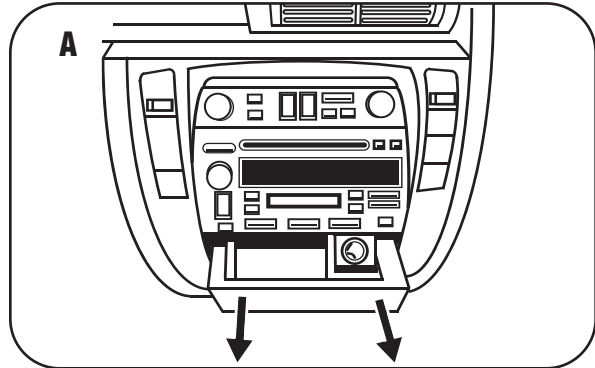

1996-1999 CADILLAC DEVILLE

- 1 Disconnect the negative battery terminal to prevent an accidental short circuit.
- 2 Unsnap and remove radio trim panel. (Open glove box to access.) (Figure A)
- 3 Pinch the side clips to disengage radio. Unplug and remove radio.

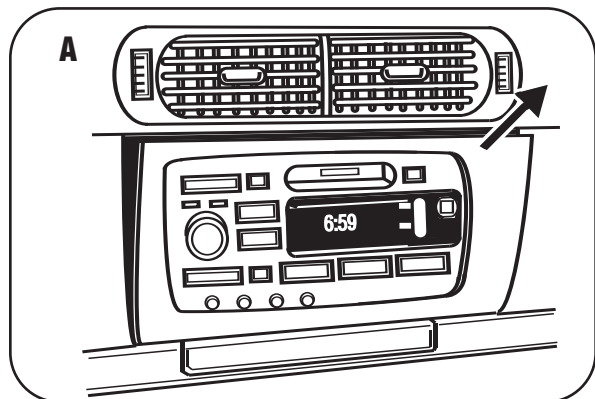

1997-2001 CADILLAC CATERA

- 1 Cut and remove the three shaded tabs on both brackets. (Figure A)

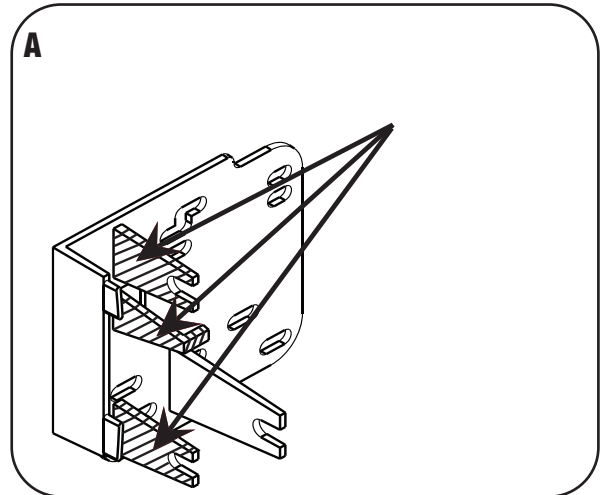

1996-1999 CADILLAC DEVILLE

- 1 Cut and remove the shaded tab from both brackets, and both of the tabs on the trim plate. (Figure B)
- 2 Install (4) speed clips into the sub-dash mounting positions. (Figure C)

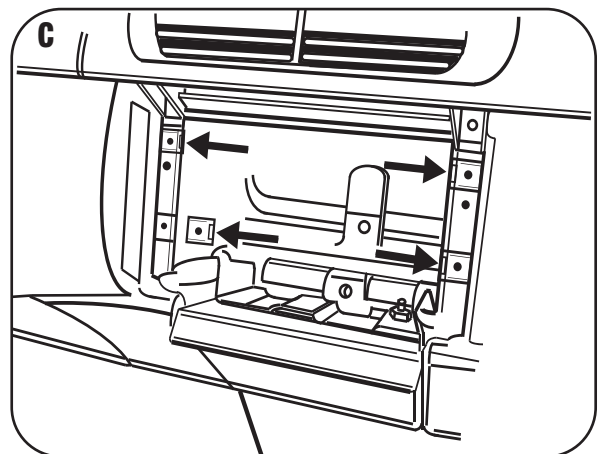
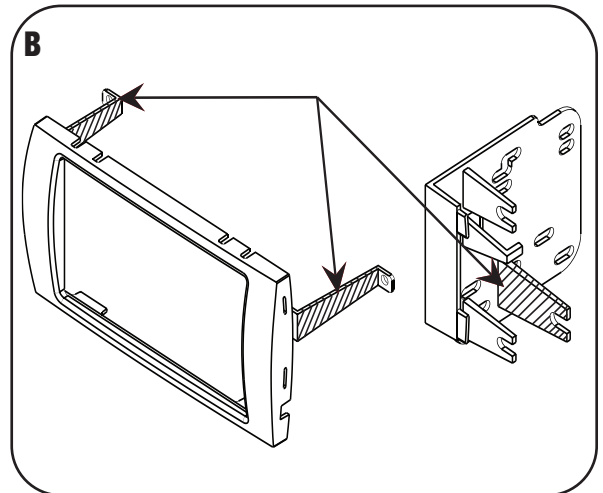

DOUBLE DIN / STACKED ISO DIN **HEAD UNIT PROVISIONS**

- 1** Locate the factory wiring harness in the dash. Metra recommends using the proper mating adapter from Metra or AXCESS. Re-connect the negative battery terminal and test the unit for proper operation.
- 2** Attach the Double DIN brackets to the inside edge of the Double DIN trim plate. (Figure A)
- 3** Slide the bracket/radio housing assembly over the Double DIN head unit and secure using the screws supplied with the radio. (Figure B)
- 4** Reassemble dash in reverse order of disassembly.

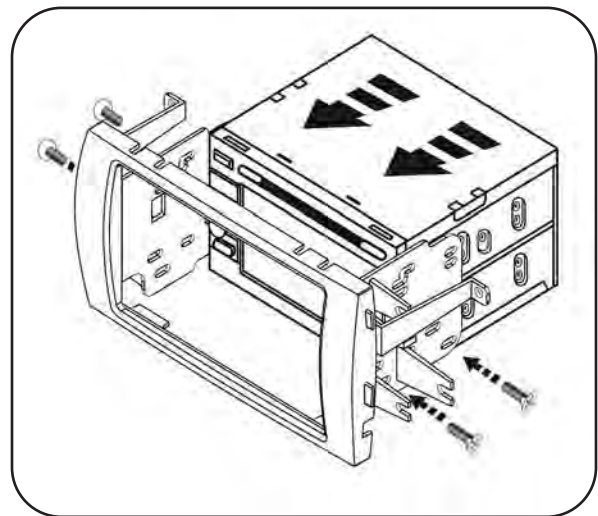
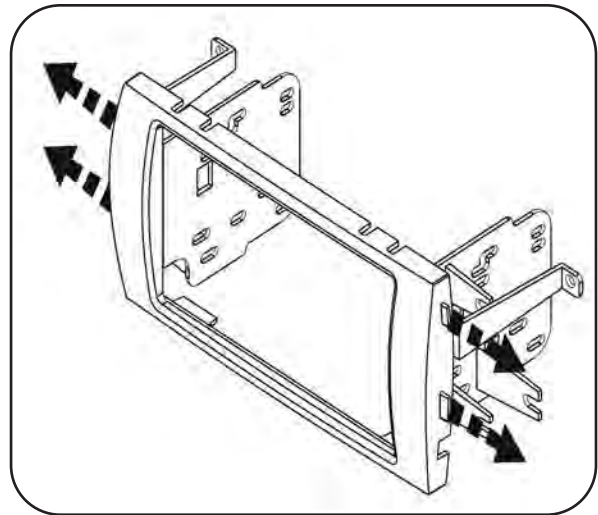

INST95-2004

METRA. THE WORLD'S BEST KITS.™



1-800-221-0932



www.metraonline.com

REV. 12/01/09

© COPYRIGHT 2004 METRA ELECTRONICS CORPORATION

INST95-2004