



INSTALLATION INSTRUCTIONS FOR PART 95-3528

APPLICATIONS

PONTIAC GTO 2004-2006

95-3528

KIT FEATURES

- Double DIN Radio Provision
- Stacked ISO Mount Units Provision



KIT COMPONENTS

A) Double DIN Brackets • B) Double DIN Trim plate

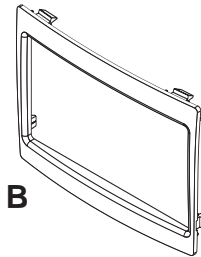
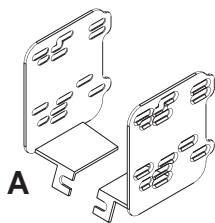

TOOLS REQUIRED:

- Small Flat Blade Screwdriver • Panel Removal Tool
• 86-3528 Radio Removal Keys

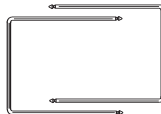

1-800-221-0932



www.metraonline.com

© COPYRIGHT 2008 METRA ELECTRONICS CORPORATION



TABLE OF CONTENTS

Dash Disassembly

- Pontiac GTO 2004-2006 1,2

Kit Assembly

- Double DIN Radio Provision 3

- Stacked ISO Mount Units Provision 4

Final Assembly 5

***Note:**

Refer also to the instructions included with the aftermarket radio.

PONTIAC GTO 2004-2006

- 1** Disconnect the negative battery terminal to prevent an accidental short circuit.
- 2** Using the radio removal keys, pull the factory radio from the dash and disconnect the wiring. (Figure A)
- 3** Unsnap and remove the trim panel at the top center of the dash above the A/C vents and remove (4) Phillips screws. (Figure B)
- 4** Remove (1) Phillips screw from inside lower open storage area where center console and dash meet. (Figure C)
- 5** Unsnap and remove center console (open center armrest/ storage compartment and work forward). (Figure D)

Continue on page 2.

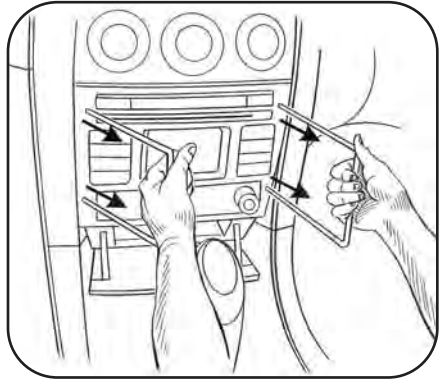
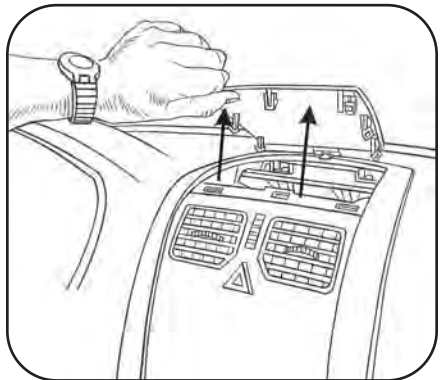
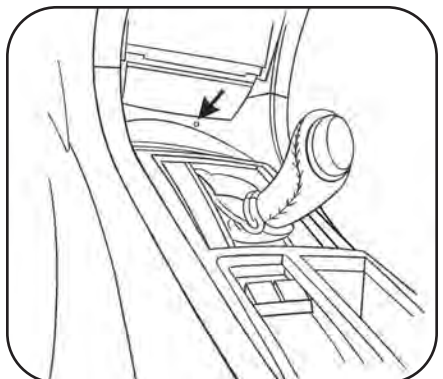
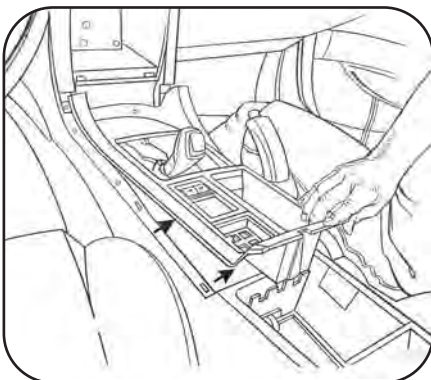
A

B

C

D

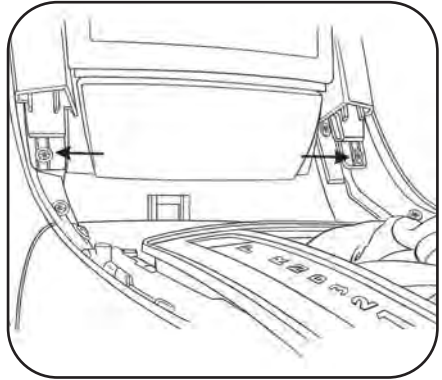
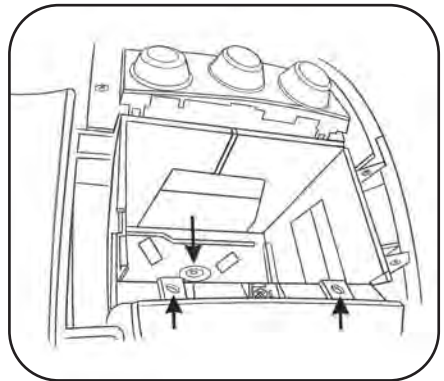
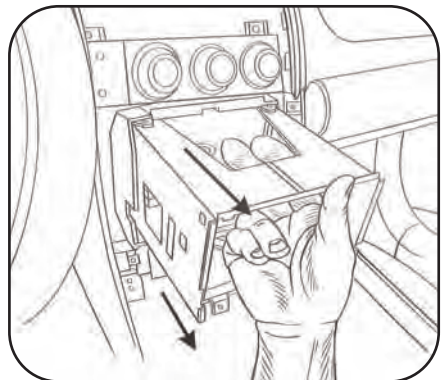
PONTIAC GTO 2004-2006

- 6** Remove (2) Phillips screws exposed at the bottom of the center panel surrounding radio and remove panel. (Figure E)
- 7** Unclip and remove trim panel surrounding radio and A/C controls.
- 8** Remove (3) Phillips screws holding "cage" in radio opening. (Figure F)
- 9** Pull down on the "cage" from the opening inside on the top and remove. (Figure G)

Continue to final assembly.

E

F

G

DOUBLE DIN RADIO PROVISION

**Note: Refer also to the instructions included with the aftermarket radio.*

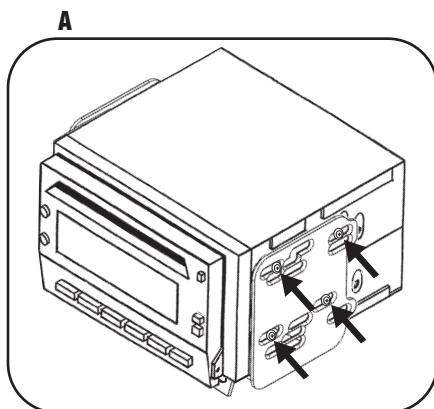
- 1 Attach the Double DIN brackets to the Double DIN radio unit using the screws supplied with the radio. (Figure A)

Continue to final assembly.



STACKED ISO MOUNT UNITS PROVISION

**Note: Refer also to the instructions included with the aftermarket radio.*

- 1 Attach the Double DIN brackets to the stacked ISO mount units using the screws supplied with the units. (Figure A)

Continue to final assembly.

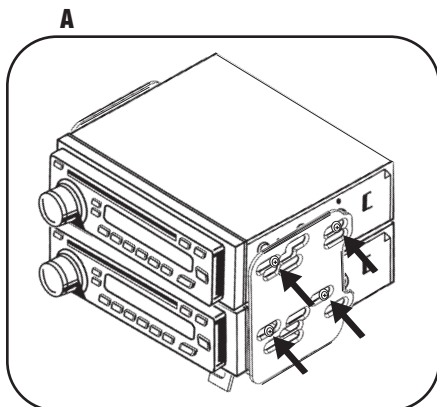

FINAL ASSEMBLY

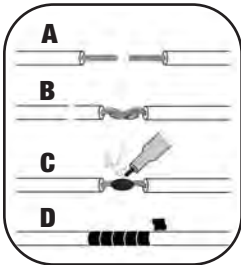

- (A) Strip wire ends back 1/2"**
- B) Twist ends together**
- C) Solder**
- D) Tape**

- 1** Locate the factory wiring harness in the dash. Metra recommends using the proper mating adapter and making connections as shown. (Isolate and individually tape off the ends of any unused wires to prevent electrical short circuit.)
- 2** Re-connect the negative battery terminal and test the unit for proper operation.
- 3** Insert and secure the radio/bracket assembly into the radio opening using the screws removed in step 8 of disassembly.
- 4** Snap the Double DIN trim plate onto the bracket/radio assembly.
- 5** Reassemble in reverse order of disassembly.

FINAL WIRING CONNECTIONS

Make wiring connections using the EIA color code chart shown below and the instructions included with the head unit. Metra recommends making connections as shown below; Strip, Splice, Solder, Tape. Isolate and individually tape off ends of any unused wires to prevent electrical short circuit.

METRA / EIA WIRING CODE

12V Ignition / Acc. Red	Right Front (+) Gray
12V Batt / Memory Yellow	Right Front (-) Gray/ Black
Ground Black*	Left Front (+) White
Power Antenna Blue	Left Front (-) White / Black
Amp Turn-On Blue / White	Right Rear (+) Violet
Amp Ground Black / White	Right Rear (-) Violet / Black
Illumination Orange	Left Rear (+) Green
Dimmer Orange / White	Left Rear (-) Green / Black

***NOTE:** When a Black wire is not present, ground radio to vehicle chassis.
All colors may not be present on all leads due to manufacturer's specifications.

95-3528 INSTRUCTIONS



1-800-221-0932



www.metraonline.com

REV. 05/07/08 © COPYRIGHT 2008 METRA ELECTRONICS CORPORATION INST95-3528