



INSTALLATION INSTRUCTIONS FOR PART 95-7309

APPLICATIONS

1996-2000 Hyundai Elantra
1995-2001 Hyundai Sonata
1997-2002 Hyundai Tiburon
2001-2006 Hyundai Santa Fe

95-7309



KIT FEATURES

- DDIN Head Unit Provision
- Stacked ISO DIN Head Unit Provision

KIT COMPONENTS

A) DDIN Trim Plate | B) DDIN Brackets C) Spacers -Thick and Thin D) 4 #10 X 3/4" Phillips Screws

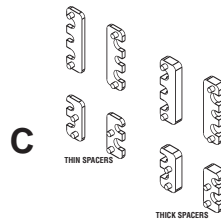
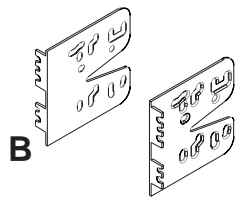
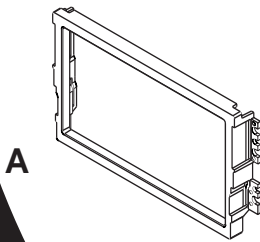

TOOLS REQUIRED:

Flat Blade Screwdriver | Phillips Screwdriver

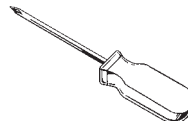
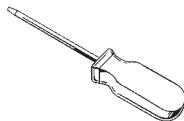

1-800-221-0932



www.metraonline.com

© COPYRIGHT 2004 METRA ELECTRONICS CORPORATION



TABLE OF CONTENTS

***Dash Disassembly** 1-5*

***Kit Assembly** 6-7*

***Final Assembly** 8*

1996-2000 HYUNDAI ELANTRA

- 1** Disconnect the negative battery terminal to prevent an accidental short circuit.
- 2** Unclip and remove the dimmer switch panel then remove (1) Phillips screw exposed behind. (Figure A)
- 3** Unclip and remove shifter trim panel. (Figure B)
- 4** Remove (1) Phillips screw at bottom of radio trim panel. (Figure C)
- 5** Unclip and remove the temperature control cable under the drivers side dash from the white plastic bracket.
- 6** Remove (4) Phillips screws securing radio.

A

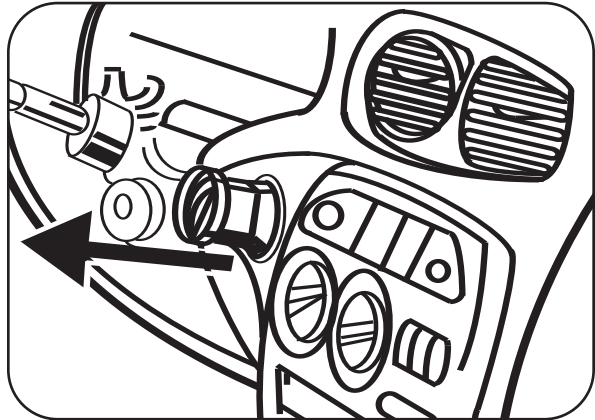

B

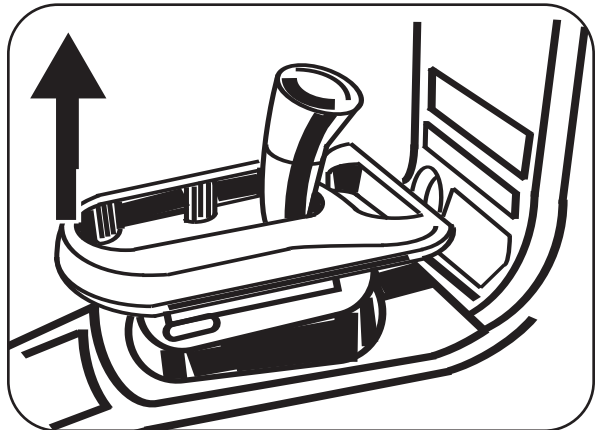

C

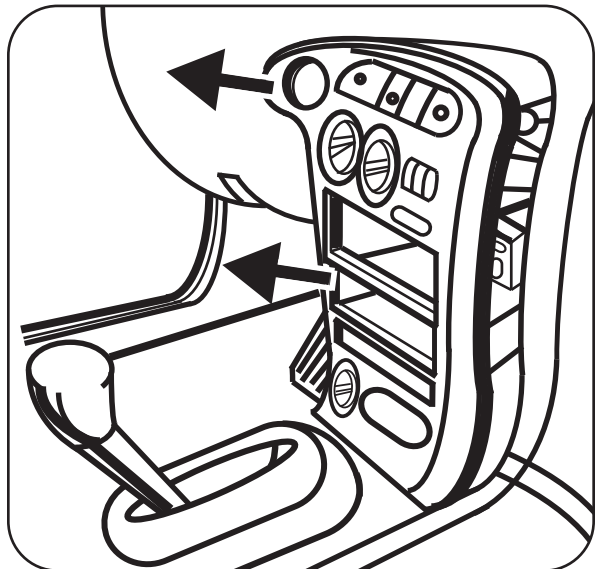

1997-2002 HYUNDAI TIBURON

- 1 Disconnect the negative battery terminal to prevent an accidental short circuit.
- 2 Unclip and remove the panel surrounding the shift lever. (Figure A)
- 3 Unclip and remove the radio trim panel. (Figure B)
- 4 Remove (2) Phillips screws securing the radio.

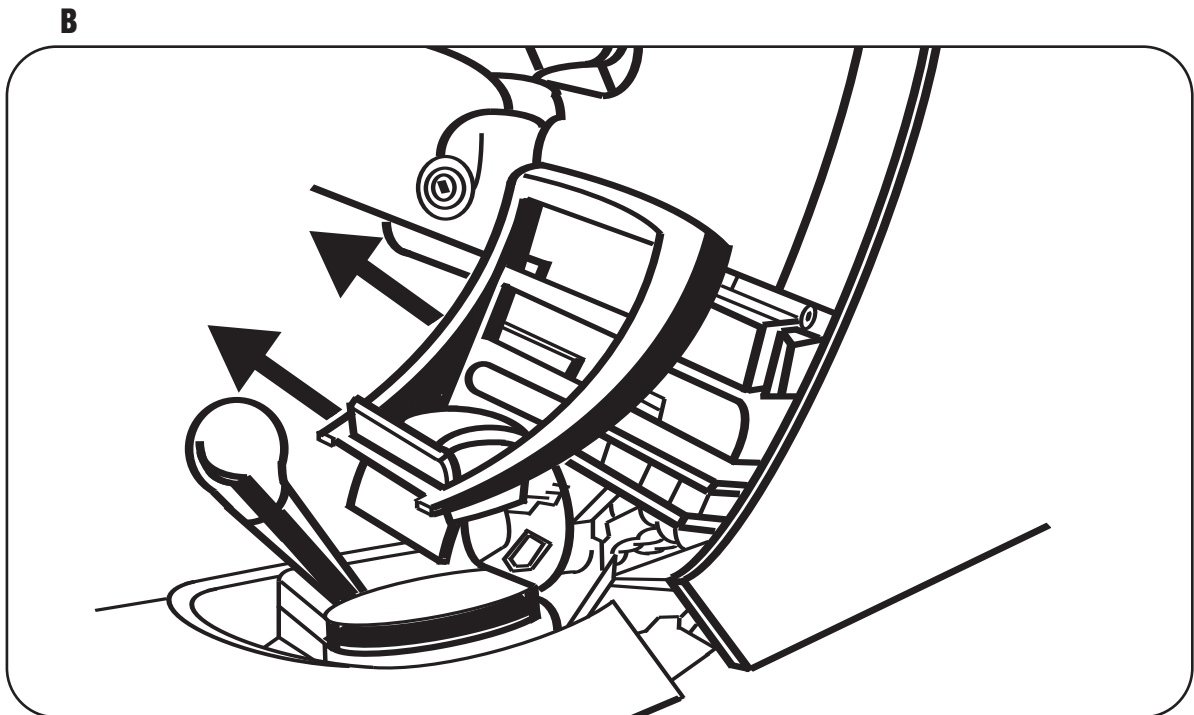
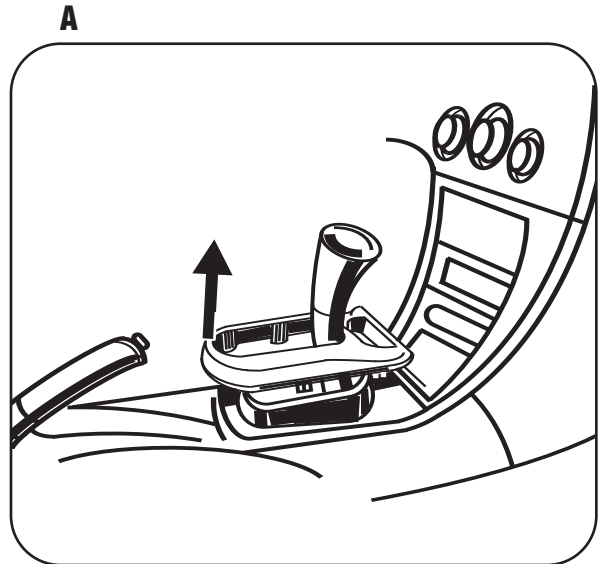

1995-1998 HYUNDAI SONATA

- 1 Disconnect the negative battery terminal to prevent an accidental short circuit.
- 2 Unclip and remove trim panel around the shifter. (Figure A)
- 3 Remove (1) Phillips screw at bottom of radio trim panel.
- 4 Unclip and remove radio trim panel. (Figure B)
- 5 Remove (4) Phillips screws securing the radio.

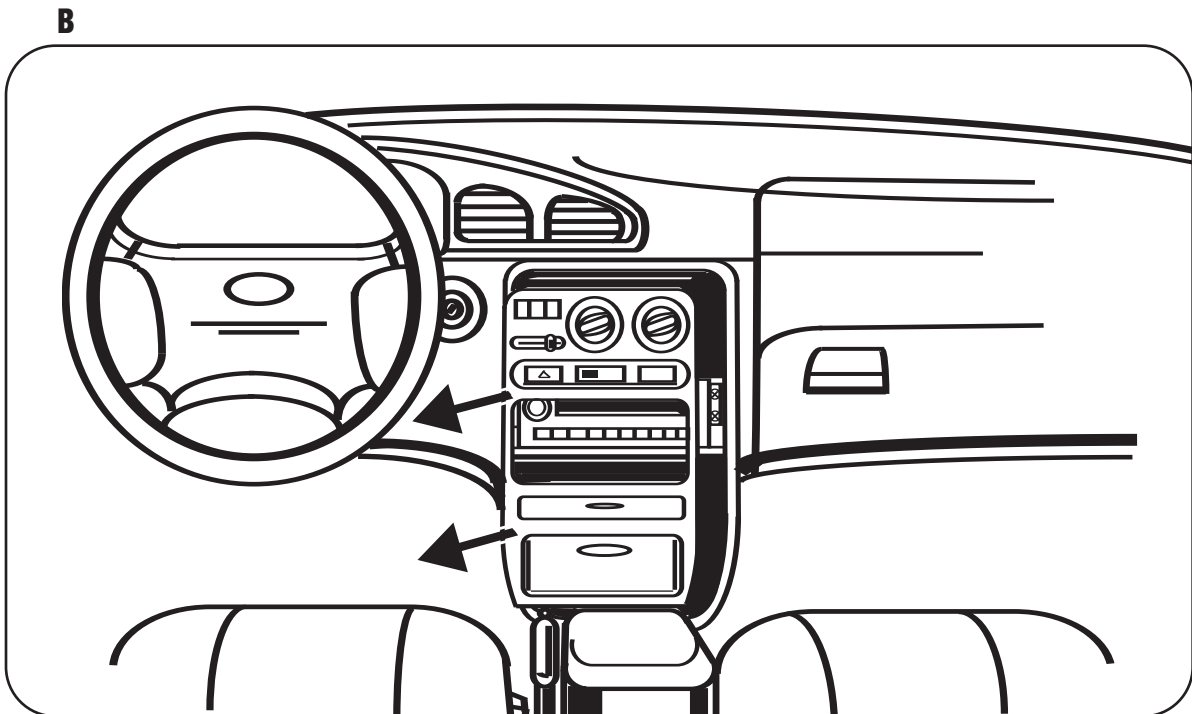
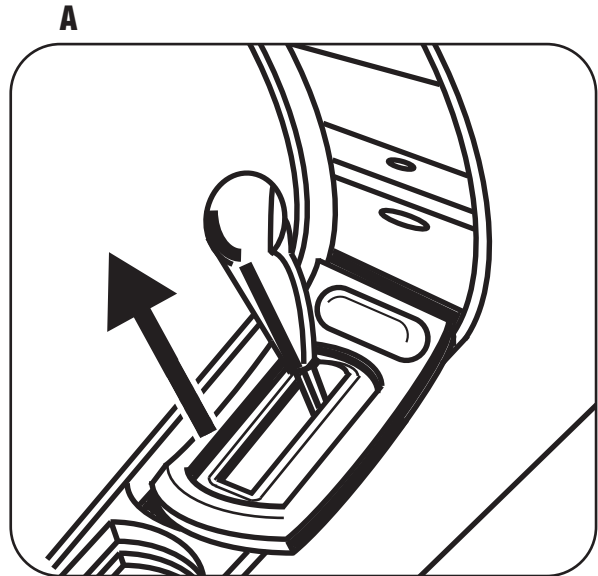

1999-2001 HYUNDAI SONATA

- 1 Disconnect the negative battery terminal to prevent an accidental short circuit.
- 2 Unclip and remove the trim panel in front of the shift lever and remove (2) Phillips screws exposed underneath. (Figure A)
- 3 Unclip and remove the shift lever trim panel. (Figure B)
- 4 Remove (2) Phillips screws at bottom of radio trim panel.
- 5 Unclip and remove radio trim panel. (Figure C)
- 6 Remove (4) Phillips screws securing the radio.

A-B

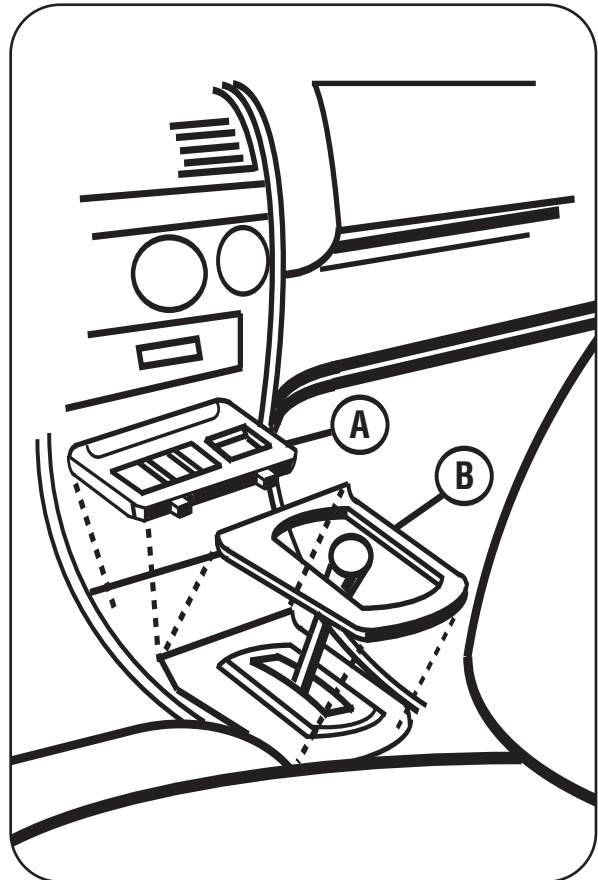

C

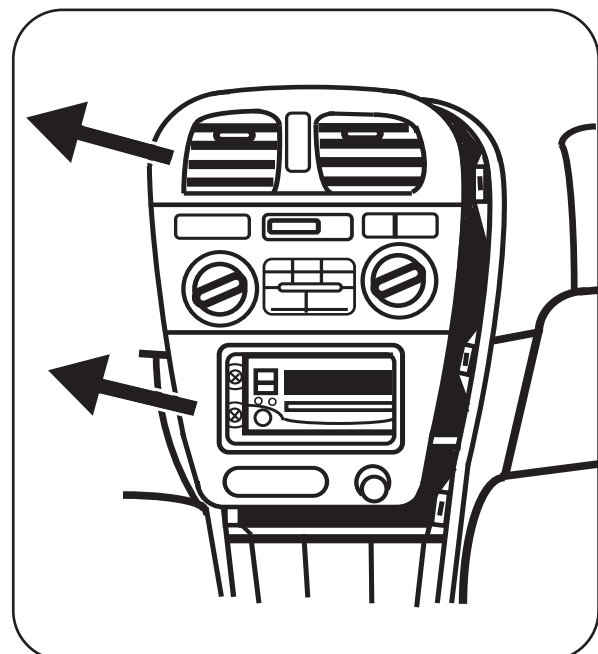

2001-2006 HYUNDAI SANTA FE

- 1 Disconnect the negative battery terminal to prevent an accidental short circuit.
- 2 Remove the ashtray and the (2) Phillips screws exposed in the cavity. (Figure A)
- 3 Unclip and remove trim panel with climate controls. (Figure B)
- 4 Remove (2) Phillips screws facing up at bottom of radio trim panel. (Figure C)
- 5 Unclip and remove the radio trim panel. (Figure D)
- 6 Remove (4) Phillips screws securing the radio.

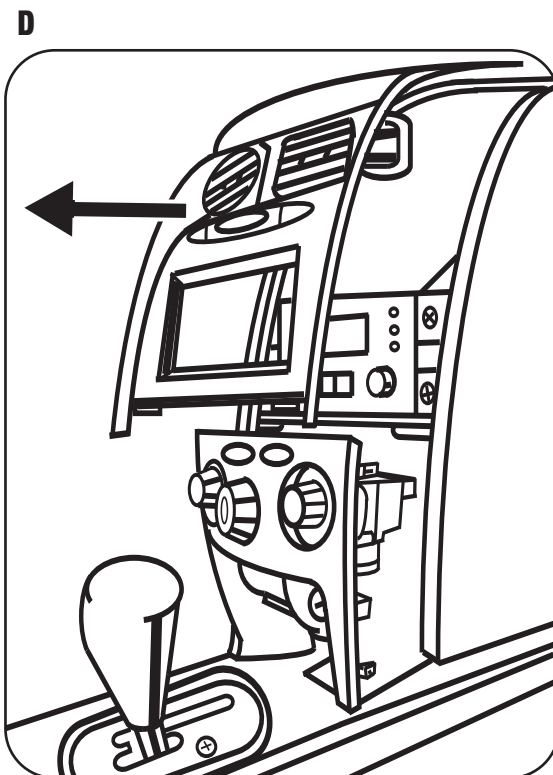
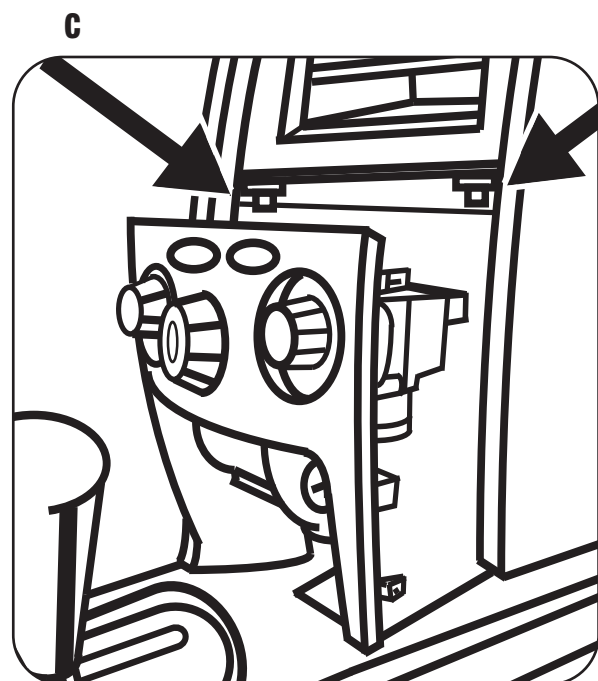
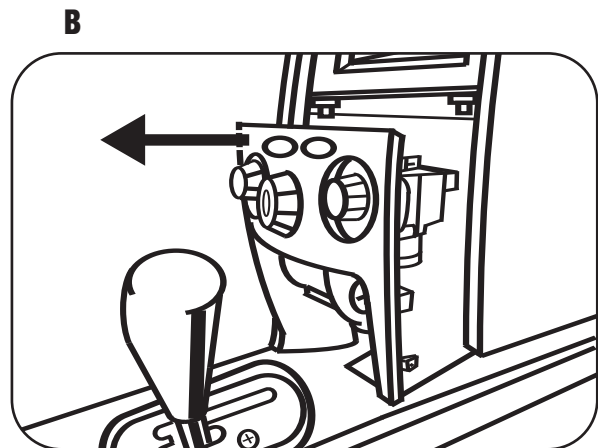
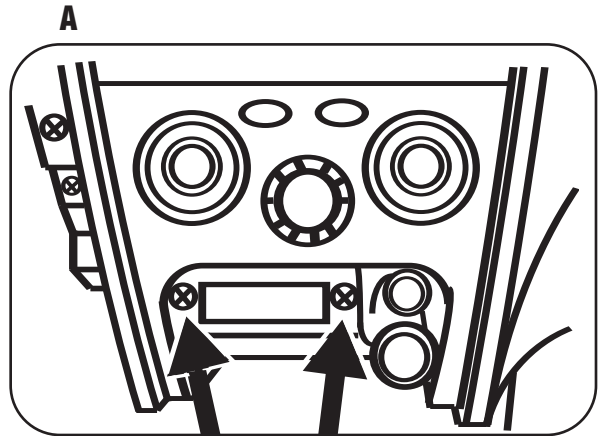

NOTE: For the Hyundai Sonata 1991-2001, Hyundai Tiburon 1997-2002, and the Hyundai Santa Fe 2001-2006 vehicles you will need to attach the provided **Thick** spacers to the DDIN brackets. (Figure A)

NOTE: Spacers will need to be removed from shipping bar.

NOTE: For the Hyundai Elantra 1996-2000 vehicles you will need to attach the provided **Thin** spacers to the DDIN brackets. (Figure B)

A

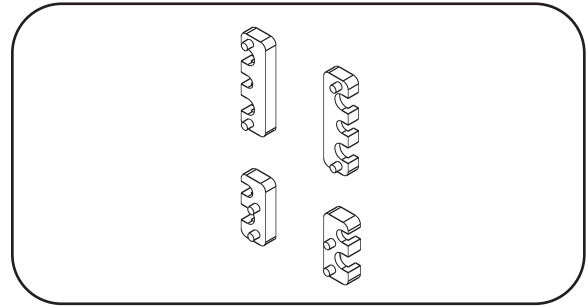

B

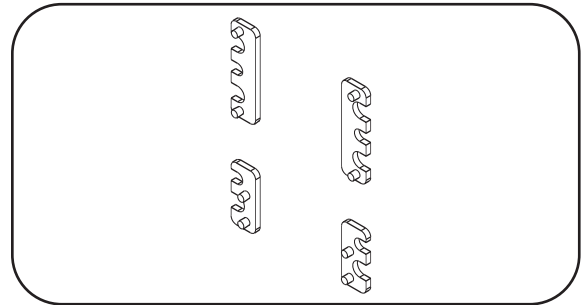

DOUBLE DIN HEAD UNIT PROVISION

- 1 Slide the appropriate bracket into the trim plate aligning the holes in the trim plate to the clips on the bracket. (Figure A)
- 2 Slide the DDIN radio unit into the trim plate bracket assembly and secure the unit to the kit using the screws supplied with the head unit. (Figure B)

A

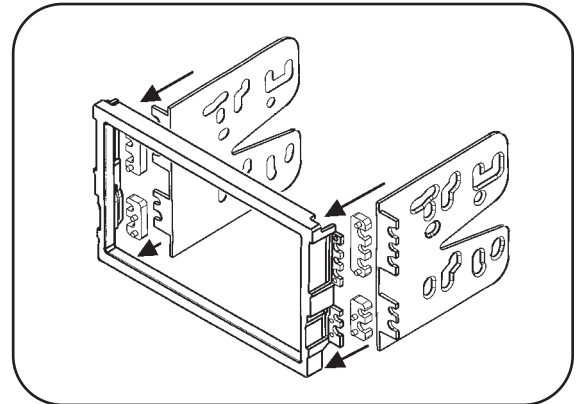

B

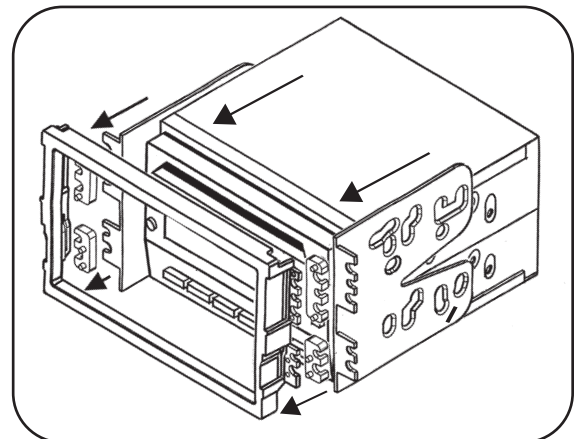

NOTE: For the Hyundai Sonata 1991-2001, Hyundai Tiburon 1997-2002, and the Hyundai Santa Fe 2001-2006 vehicles you will need to attach the provided **Thick** spacers to the DDIN brackets. (Figure A)

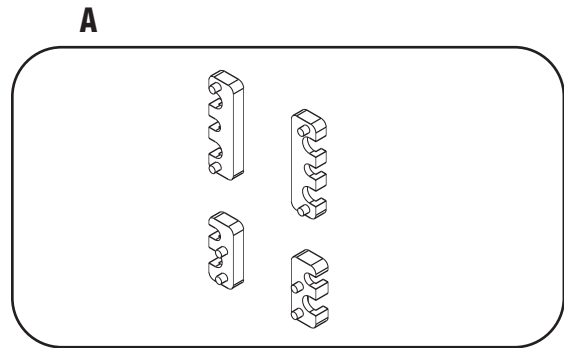

NOTE: Spacers will need to be removed from shipping bar.

NOTE: For the Hyundai Elantra 1996-2000 vehicles you will need to attach the provided **Thin** spacers to the DDIN brackets. (Figure B)

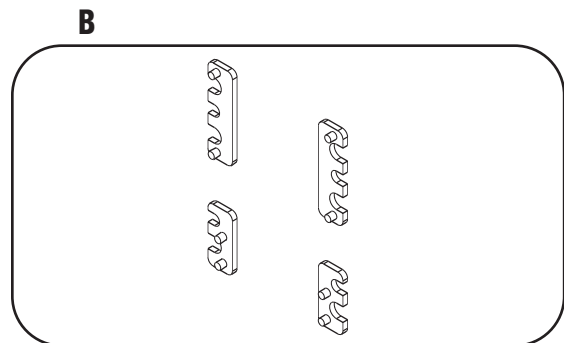

STACKED ISO DIN HEAD UNIT PROVISION

- 1 Slide the appropriate bracket into the trim plate aligning the holes in the trim plate to the clips on the bracket. (Figure A)
- 2 Slide the stacked ISO DIN units into the trim plate bracket assembly and secure the unit to the kit using the screws supplied with the head unit. (Figure B)

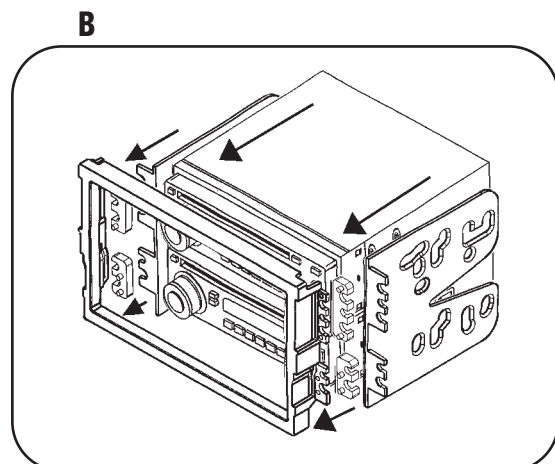
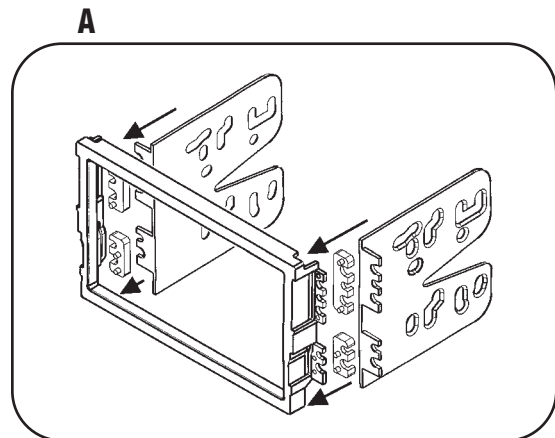

FINAL ASSEMBLY

- 1 Locate the factory wiring harness in the dash and make the connection as shown. Metra recommends using the proper mating adapter and making the connections as shown. (Isolate and individually tape off the ends of any unused wires to prevent electrical short circuit.)
- 2 Re-connect the negative battery terminal and test the unit for proper operation.
- 3 Reassemble radio and dash assemblies in reverse order of disassembly.

FINAL WIRING CONNECTIONS

Make wiring connections using the EIA color code chart shown below and the instructions included with the head unit. Metra recommends making connections as shown below; Strip, Splice, Solder, Tape. Isolate and individually tape off ends of any unused wires to prevent electrical short circuit.

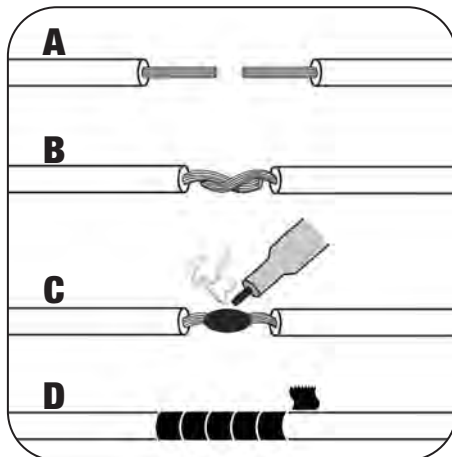

- A) Strip wire ends back 1/2"**
- B) Twist ends together**
- C) Solder**
- D) Tape**

METRA / EIA WIRING CODE

12V Ignition / Acc . . . Red	Right Front (+) Gray
12V Batt / Memory . . Yellow	Right Front (-) Gray / Black
Ground Black*	Left Front (+) White
Power Antenna Blue	Left Front (-) White / Black
Amp Turn-On Blue / White	Right Rear (+) Violet
Amp Ground Black / White	Right Rear (-) Violet / Black
Illumination. Orange	Left Rear (+) Green
Dimmer Orange / White	Left Rear (-) Green / Black

***NOTE:** When Black a wire is not present, ground radio to vehicle chassis.
All colors may not be present on all leads due to manufacturer's specifications.

95-7309 INSTRUCTIONS



1-800-221-0932



www.metraonline.com

REV. 12/12/05

© COPYRIGHT 2004 METRA ELECTRONICS CORPORATION

INST95-7309