



INSTALLATION INSTRUCTIONS FOR PART 95-7328

APPLICATIONS

KIA Sorento 2007

95-7328

KIT FEATURES

- Double DIN Radio Provision
- Stacked ISO Mount Units Provision



KIT COMPONENTS

A) Double DIN Trim Plate B) Double DIN Brackets

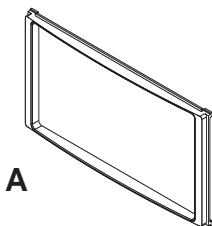

A

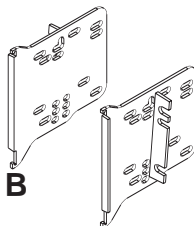

B

TOOLS REQUIRED:

- Small Flat Blade Screwdriver/ Panel Removal Tool
- Phillips Screwdriver • Flat Blade Screwdriver



1-800-221-0932



www.metraonline.com

© COPYRIGHT 2004 METRA ELECTRONICS CORPORATION

TABLE OF CONTENTS

Dash Disassembly

- KIA Sorento 2007	1
--------------------------	---

Kit Assembly

- Double DIN Radio Provision	2
- Stacked ISO Mount Units Provision	3

<u>Final Assembly</u>	4
------------------------------------	---

***Note:**

Refer also to the instructions included with the aftermarket radio.

KIA SORENTO 2007

- 1 Disconnect the negative battery terminal to prevent an accidental short circuit.
- 2 Unclip and remove the side trim panels. (Tip: start at the bottom of the panels) (Figure A)
- 3 Remove (2) Phillips head screws securing the radio trim panel. Unplug and remove panel. (Figure B)
- 4 Remove (2) Phillips head screws securing the vent panels then unclip and remove the (2) vent panels. (Figure C)
- 5 Remove (4) Phillips screws securing the radio. Unplug and remove radio.

Continue to kit assembly.

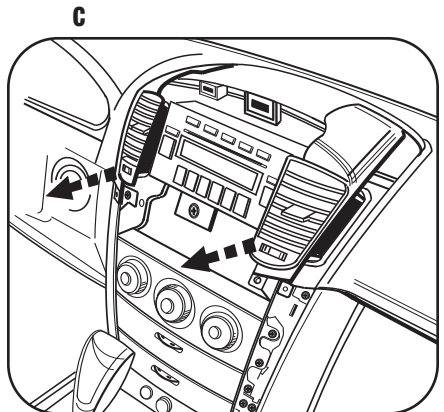
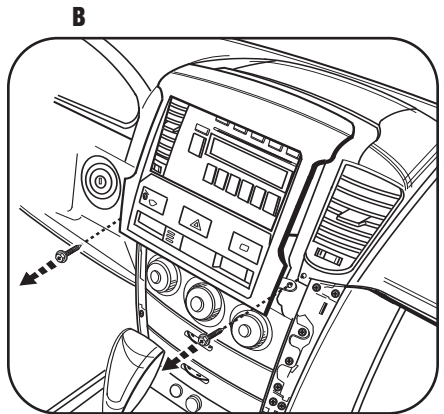
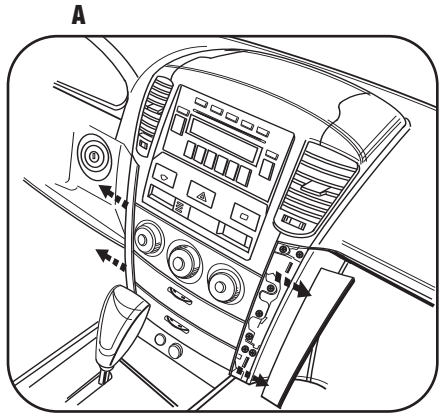

DOUBLE DIN RADIO PROVISION

**Note: Refer also to the instructions included with the aftermarket radio.*

- 1 Snap the Double DIN brackets to the outside edge of the Double DIN trim plate. (Figure A)
- 2 Slide the Double DIN radio into the bracket/trim plate assembly and secure the radio to the assembly using the screws supplied with the radio. (Figure B)

Continue to final assembly.

A

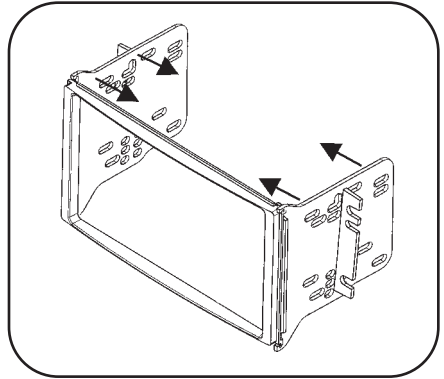

B

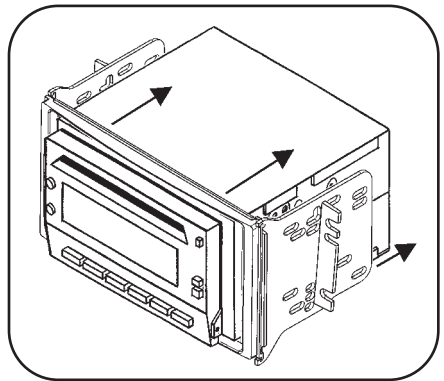

STACKED ISO MOUNT UNITS PROVISION

**Note: Refer also to the instructions included with the aftermarket radio.*

- 1 Snap the Double DIN brackets to the outside edge of the Double DIN trim plate. (Figure B)
- 2 Slide the stacked ISO mount units into the bracket/trim plate housing assembly and secure the units to the assembly using the screws supplied with the units. (Figure C)

Continue to final assembly.

A

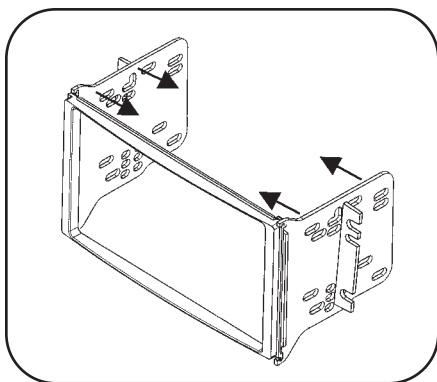

B

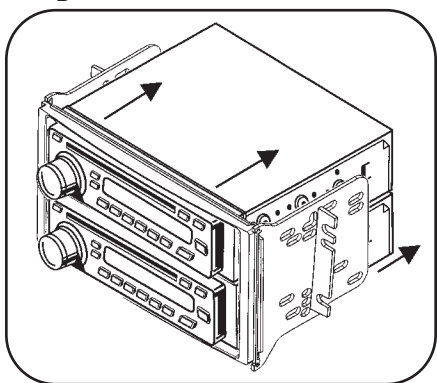

FINAL ASSEMBLY

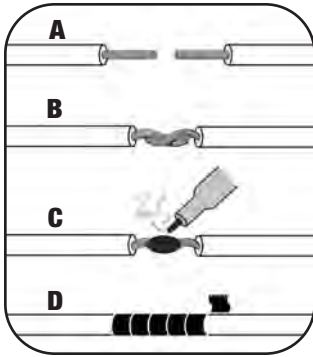

(A) Strip wire ends back 1/2"

B) Twist ends together

C) Solder

D) Tape

- 1 Locate the factory wiring harness in the dash. Metra recommends using the proper mating adapter and making connections as shown. (Isolate and individually tape off the ends of any unused wires to prevent electrical short circuit.)
- 2 Re-connect the negative battery terminal and test the unit for proper operation.
- 3 Reassemble radio and dash assemblies in reverse order of disassembly.

FINAL WIRING CONNECTIONS

Make wiring connections using the EIA color code chart shown below and the instructions included with the head unit. Metra recommends making connections as shown below; Strip, Splice, Solder, Tape. Isolate and individually tape off ends of any unused wires to prevent electrical short circuit.

METRA / EIA WIRING CODE

12V Ignition / Acc. Red	Right Front (+) Gray
12V Batt / Memory Yellow	Right Front (-) Gray / Black
Ground Black*	Left Front (+) White
Power Antenna Blue	Left Front (-) White / Black
Amp Turn-On Blue / White	Right Rear (+) Violet
Amp Ground Black / White	Right Rear (-) Violet / Black
Illumination Orange	Left Rear (+) Green
Dimmer Orange / White	Left Rear (-) Green / Black

***NOTE:** When a Black wire is not present, ground radio to vehicle chassis.

All colors may not be present on all leads due to manufacturer's specifications.

95-7328 INSTRUCTIONS



1-800-221-0932



www.metraonline.com

REV. 2/22/07 © COPYRIGHT 2004 METRA ELECTRONICS CORPORATION

INST95-7328