



INSTALLATION INSTRUCTIONS FOR PART 95-7899

APPLICATIONS

2001-2005 Honda Civic (Except 2005 Civic SE)

95-7899



KIT FEATURES

- Double DIN Head Unit Provision
- Stacked ISO DIN Head Unit Provision

KIT COMPONENTS

- A) Double DIN Trim Plate

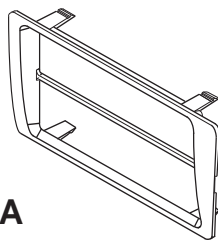

TOOLS REQUIRED:

Phillips Screwdriver • Utility Knife • Socket Wrench

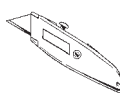
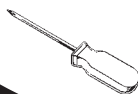

1-800-221-0932



www.metraonline.com

© COPYRIGHT 2004-2008 METRA ELECTRONICS CORPORATION



TABLE OF CONTENTS

Dash Disassembly

- 2001-2005 Honda Civic (Except 2005 Civic SE)

Center Console Without Armrest 1

Center Console With Armrest 2

Kit Assembly

- Double DIN Head Unit Provision 3

- Stacked ISO Head Unit Provision 4

Final Assembly 5

2001-2005 HONDA CIVIC (EXCEPT 2005 CIVIC SE)
CENTER CONSOLE WITHOUT ARMREST

- 1 Disconnect the negative battery terminal to prevent an accidental short circuit.
- 2 Unclip the parking brake trim panel and remove (2) Phillips screws exposed. (Figure A)
- 3 Remove (1) Phillips screw and (1) clip from each side of the center console. (Figure B) Slide the console rearward to access (2) Phillips screws on the power outlet panel. (Figure C)
- 4 **With ashtray:** Remove the ashtray and (1) screw from inside ashtray cavity.
Without ashtray: Skip to step five.
- 5 Unclip the power outlet panel and remove (2) Phillips screws exposed. (Figure C)
- 6 Unclip the dash trim panel assembly (including the head unit and the climate controls) and remove assembly.
- 7 Remove (3) screws securing the climate control pod to the back of the assembly and remove pod.
- 8 Remove (4) Phillips screws securing the factory head unit to the bracket assembly and remove the unit. (Figure D)

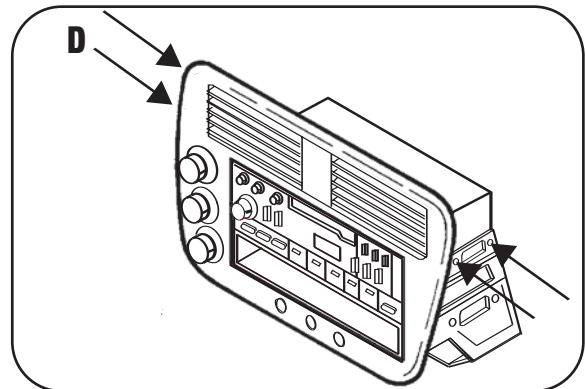
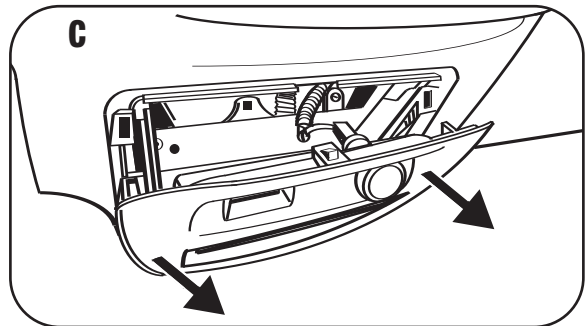
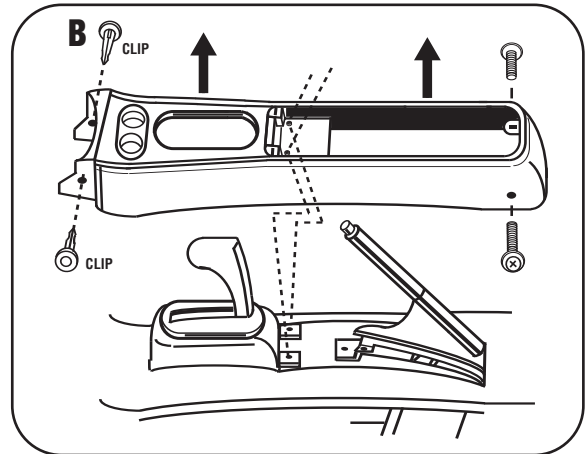
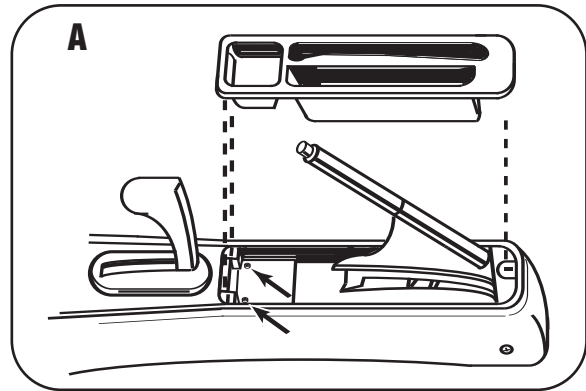

2001-2005 HONDA CIVIC (EXCEPT 2005 CIVIC SE)**CENTER CONSOLE WITH ARMREST**

- 1 Disconnect the negative battery terminal to prevent an accidental short circuit.
- 2 **Automatic transmission:**
 - a. Apply parking brake and place shifter in neutral position.
 - b. Unclip and remove trimring around shifter. (Figure A)

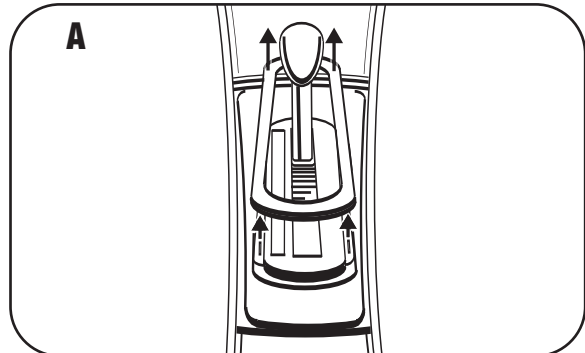
**Manual transmission:**

- a. Apply parking brake
- b. Remove the shifter knob by holding the plastic section above the boot down firmly with one hand and turning the knob counterclockwise with the other hand.

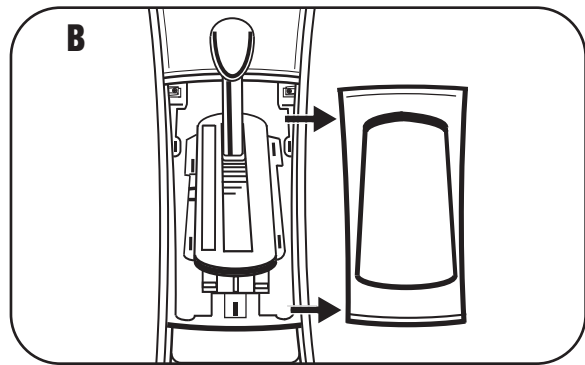

- 3 Unclip and remove center console trim panel (Figure B) and remove (2) screws exposed. (Figure C)

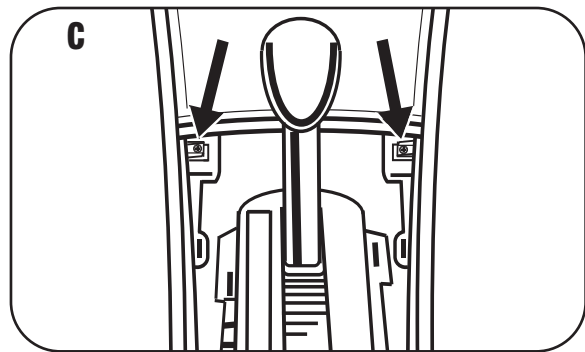

- 4 **With ashtray:** Remove the ashtray and (1) screw from inside ashtray cavity.

Without ashtray: Skip to step five.

- 5 Gently pry out on the center console edge trim (Figure D) to release the four rear clips, then pull the trim toward the rear to release the remaining clips and remove (2) Phillips screws exposed.

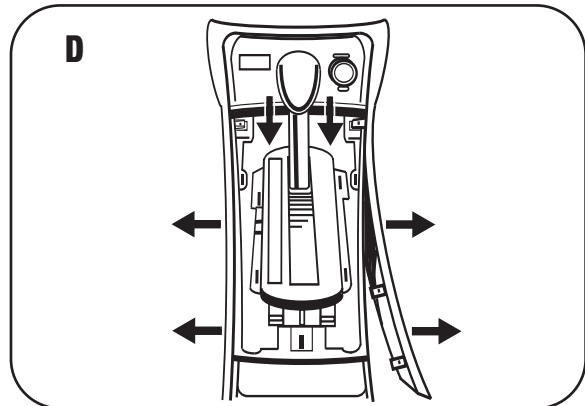

- 6 Unclip the dash trim panel assembly (including the head unit and the climate controls) and remove assembly.

- 7 Remove (3) screws securing the climate control pod to the back of the assembly and remove pod.

- 8 Remove (4) Phillips screws securing the factory head unit to the bracket assembly and remove the unit.

DOUBLE DIN HEAD UNIT PROVISION

- 1** Remove the center bar from DDIN Trimplate. (Figure A)
- 2** Snap the DDIN Trimplate into the bracket and unit assembly. (Figure B)
- 3** Attach the aftermarket radio to the factory brackets by aligning the holes and securing it to the brackets using the screws supplied with radio. (Figure C)
- 4** Skip to step #1 in the Final Assembly.

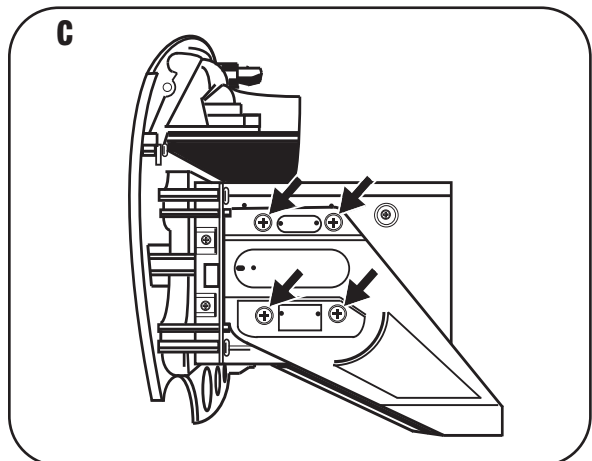
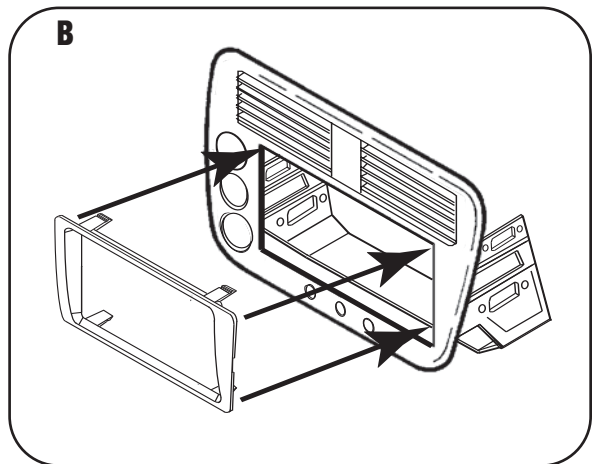
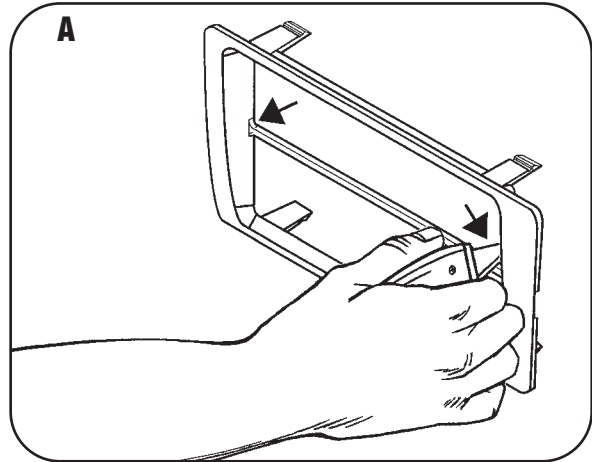

STACKED ISO HEAD UNIT PROVISION

- 1 Depending on the type of aftermarket head units being installed (ie: Flip down, removable and motorized faced head units) the center bar may have to be removed and a small portion of the inside top and bottom edge of the DDIN Trimplate may have to be filed slightly. (Figure A)
- 2 Snap the DDIN Trimplate to the bracket & unit assembly. (Figure B)
- 3 Attach the stacked head units to the factory brackets by aligning the holes and securing them to the brackets using the screws supplied with the units. (Figure C)
- 4 Skip to step #1 in the Final Assembly.

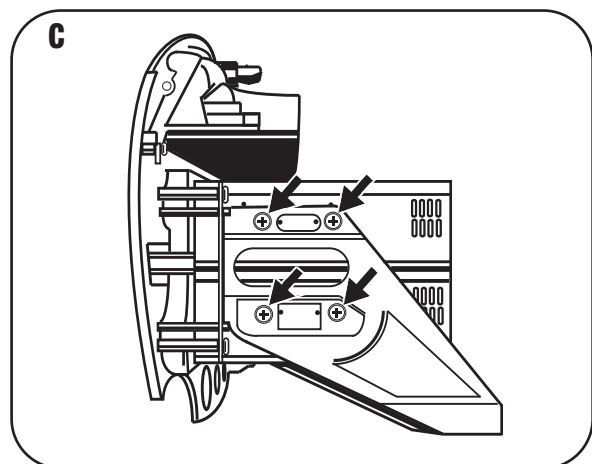
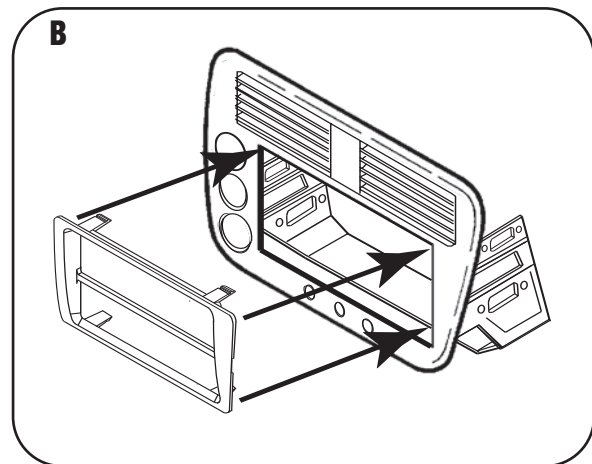
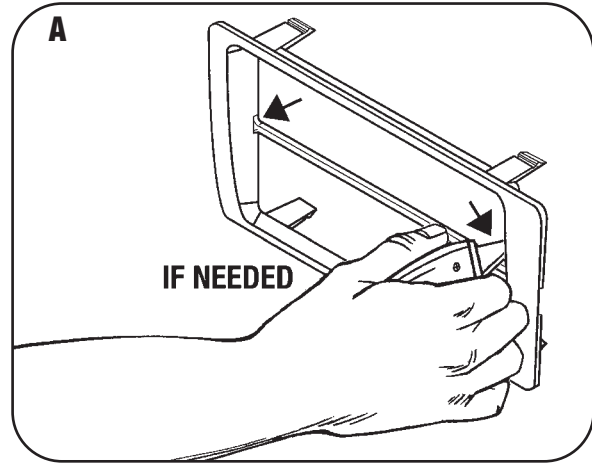

FINAL ASSEMBLY

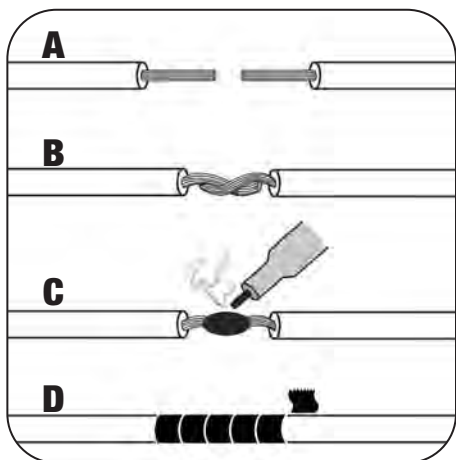

- A) Strip wire ends back 1/2"**
- B) Twist ends together**
- C) Solder**
- D) Tape**

- 1** Locate the factory wiring harness in the dash and make the connection as shown. Metra recommends using the proper mating adapter and making the connections as shown. (Isolate and individually tape off the ends of any unused wires to prevent electrical short circuit.)
- 2** Re-connect the negative battery terminal and test the unit for proper operation.
- 3** Reassemble radio and dash assemblies in reverse order of disassembly.

FINAL WIRING CONNECTIONS

Make wiring connections using the EIA color code chart shown below and the instructions included with the head unit. Metra recommends making connections as shown below; Strip, Splice, Solder, Tape. Isolate and individually tape off ends of any unused wires to prevent electrical short circuit.

METRA / EIA WIRING CODE

12V Ignition / Acc . . . Red	Right Front (+) Gray
12V Batt / Memory . . Yellow	Right Front (-) Gray/ Black
Ground Black*	Left Front (+) White
Power Antenna Blue	Left Front (-) White / Black
Amp Turn-On Blue / White	Right Rear (+) Violet
Amp Ground Black / White	Right Rear (-) Violet / Black
Illumination Orange	Left Rear (+) Green
Dimmer Orange / White	Left Rear (-) Green / Black

***NOTE:** When a Black wire is not present, ground radio to vehicle chassis.

All colors may not be present on all leads due to manufacturer's specifications.

95-7899 INSTRUCTIONS



1-800-221-0932



www.metraonline.com

REV. 04/15/08

© COPYRIGHT 2004-2008 METRA ELECTRONICS CORPORATION

INST95-7899