



INSTALLATION INSTRUCTIONS FOR PART 95-8202

APPLICATIONS

Toyota
Rav 4 2001-05
MR2 Spider 2000-03
Celica 2000-05
Echo 2000-05
Highlander 2001-07
Matrix 2005-08/ Matrix 2009 (With Factory Navigation)
4 Runner (Excluding Limited) 2003-09
Tundra 2003-06
Sequoia 2003-07
FJ Cruiser 2007-09
Yaris 2007-2009
Scion TC 2005-09 / XA 2004-06 / XB 2004-09 / XD 2008-09

95-8202



KIT FEATURES

- DDIN Head Unit Provision
- Stacked ISO DIN Head Unit Provision

KIT COMPONENTS

A) DDIN Trim plates

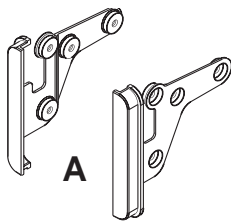

WIRING AND ANTENNA CONNECTIONS (Sold Separately)

Wiring Harness:

- 70-1761 - Toyota harness 1987-up
- TYT0-01 - Toyota amp harness 2003-up

Antenna Adapter:

- Not required

TOOLS REQUIRED:

Cutting Tool • Phillips Screwdriver • Socket Set • Grinder

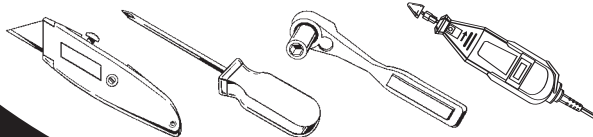

1-800-221-0932



www.metraonline.com

© COPYRIGHT 2004-2009 METRA ELECTRONICS CORPORATION

TABLE OF CONTENTS

Dash Disassembly

<i>Toyota Rav 4 2001-2005.....</i>	<i>1</i>
<i>Toyota MR2 Spyder 2000-2003</i>	<i>2</i>
<i>Toyota Celica 2000-2005</i>	<i>3</i>
<i>Toyota Echo 2000-2005</i>	<i>4</i>
<i>Toyota Highlander 2001-2007</i>	<i>5</i>
<i>Toyota Matrix 2005-2008</i>	<i>6</i>
<i>Toyota Matrix 2009 (With Factory Navigation).....</i>	<i>7</i>
<i>Toyota 4 Runner (Excluding Limited) 2003-2009</i>	<i>8</i>
<i>Toyota Tundra 2003-2006</i>	<i>9</i>
<i>Toyota Sequoia 2003-2006</i>	<i>10</i>
<i>Toyota FJ Cruiser 2007-2009.....</i>	<i>11</i>
<i>Yaris 2007-2009</i>	<i>12</i>
<i>Scion XA 2004-2006</i>	<i>13</i>
<i>Scion XB 2004-2007</i>	<i>14</i>
<i>Scion XB 2008-2009</i>	<i>15</i>
<i>Scion TC 2005-2009</i>	<i>16</i>
<i>Scion XD 2008-2009</i>	<i>17</i>

Kit Assembly

<i>Double DIN Head Unit Provision.....</i>	<i>18</i>
<i>Stacked ISO DIN Head Unit Provision</i>	<i>18</i>

<i>Final Assembly</i>	<i>19</i>
------------------------------------	------------------

TOYOTA RAV 4 2001-2005

- 1** Disconnect the negative battery terminal to prevent an accidental short circuit.
- 2** Unclip and remove side panel from both sides of radio and climate controls. **Figure A)**
- 3** Remove (4) Phillips screws securing the radio/climate control trim panel. **(Figure B)**
- 4** Remove (4) 10 MM bolts securing the radio. **(Figure C)**
- 5** Unplug and remove radio.
- 6** Remove factory brackets from radio. Retain brackets for use during kit assembly.
- 7** *Continue to kit assembly.*

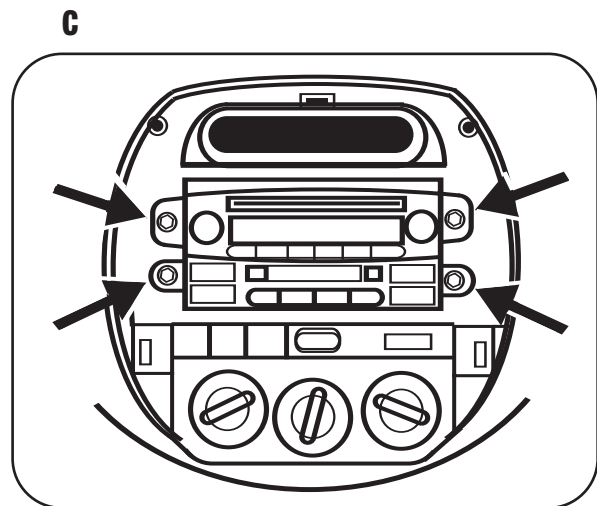
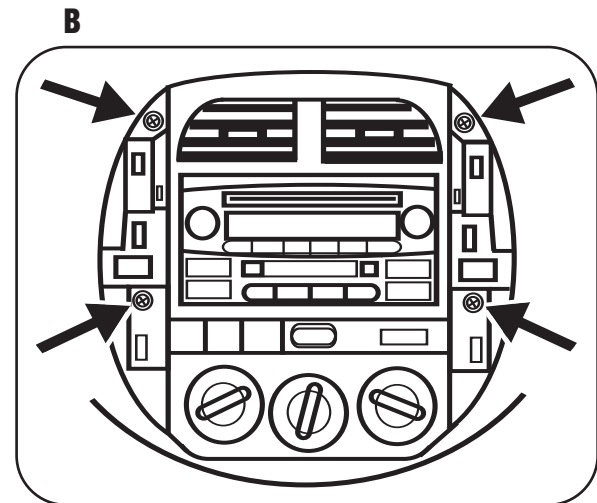
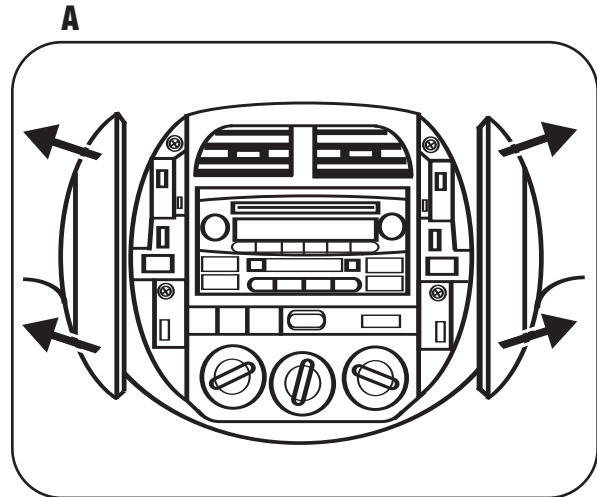

TOYOTA MR2 SPYDER 2000-2003

- 1** Disconnect the negative battery terminal to prevent an accidental short circuit.
- 2** Unsnap the lower trim piece from each side of the dash console and remove (2) Phillips screws exposed in each cavity. Remove the upper trim piece from each side of the console. (Figure A)
- 3** Remove the climate control knobs and (2) Phillips screws exposed. Remove the climate control trim bezel. (Figure A)
- 4** Remove the ashtray and (1) 10mm bolt exposed. Unclip the ashtray trim bezel and remove. (Figure A)
- 5** Unclip the radio trim bezel, remove (4) Phillips screws securing the unit and disconnect the wiring.
- 6** Remove factory brackets from radio. Retain brackets for use during kit assembly.
- 7** *Continue to kit assembly.*

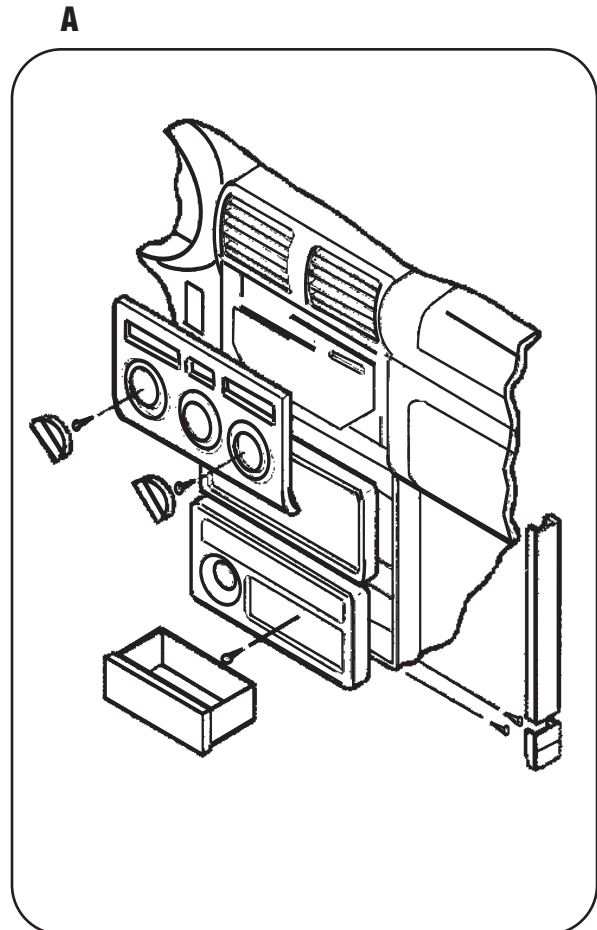

TOYOTA CELICA 2000-2005

- 1** Disconnect the negative battery terminal to prevent an accidental short circuit.
- 2** Unclip and remove the gear shifter trim bezel and remove (2) Phillips screws exposed below the climate controls. (Figure A)
- 3** Pull off climate control knobs and remove (2) Phillips screws exposed. (Figure A)
- 4** Unclip the climate control/factory radio trim bezel and remove. (Figure A)
- 5** Remove (4) 10mm screws securing the factory head unit and disconnect the wiring.
- 6** Remove factory brackets from radio. Retain brackets for use during kit assembly.
- 7** *Continue to kit assembly.*

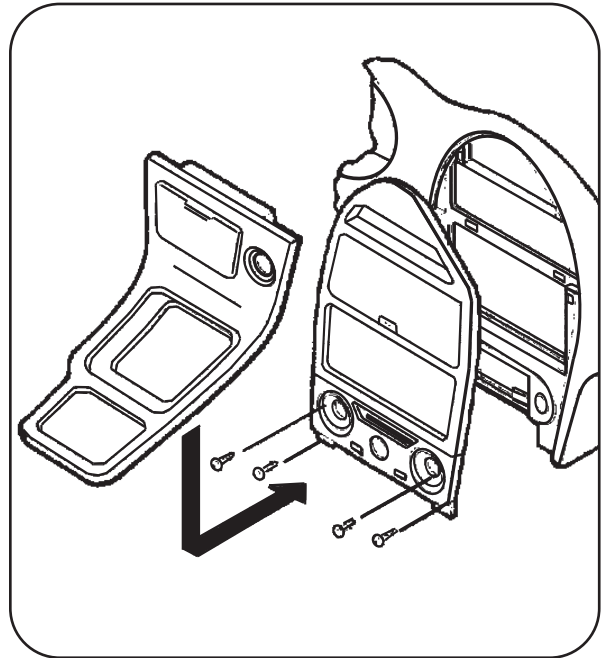
A

TOYOTA ECHO 2000-2005

- 1** Disconnect the negative battery terminal to prevent an accidental short circuit.
- 2** Remove the climate control knobs and (2) Phillips screws exposed. Unclip and remove the climate control trim bezel. Depress the side clips securing the climate control panel and move the panel to access (2) Phillips screws from the top of the factory radio brackets. **(Figure A)**
- 3** Remove the ashtray. Unclip and remove the radio trim bezel. Remove (2) Phillips screws from the bottom of the radio brackets and disconnect the wiring.
- 4** Remove factory brackets from radio. Retain brackets for use during kit assembly.
- 5** *Continue to kit assembly.*

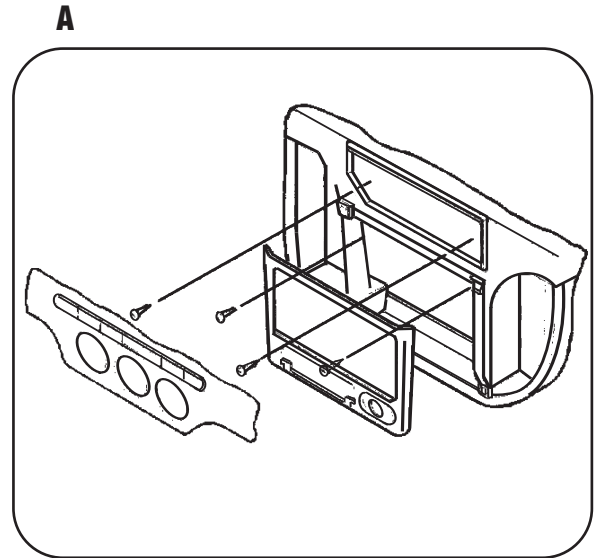

TOYOTA HIGHLANDER 2001-2007

- 1** Disconnect the negative battery terminal to prevent an accidental short circuit.
- 2** Pull and remove dash panel from radio and climate controls. Tip: There are 8 clips. (Figure A)
- 3** Remove (6) 10mm bolts from radio and climate controls assembly. (Figure B)
- 4** Remove assembly and disconnect the wiring.
- 5** Remove (8) Phillips bolts and (4) Phillips screws to separate brackets from assembly. Retain brackets for use during kit assembly. (Figure C)
- 6** *Continue to kit assembly.*

A

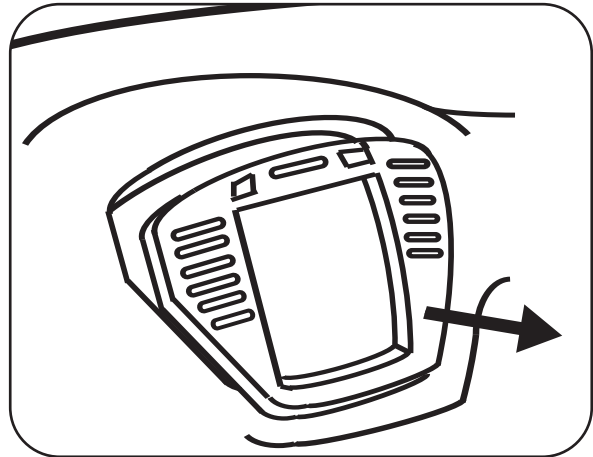

B

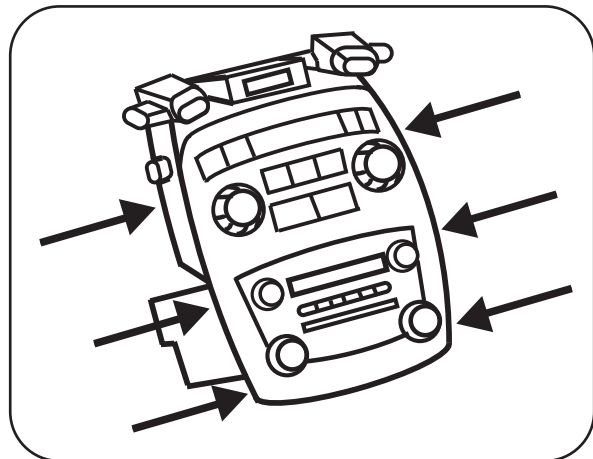

C

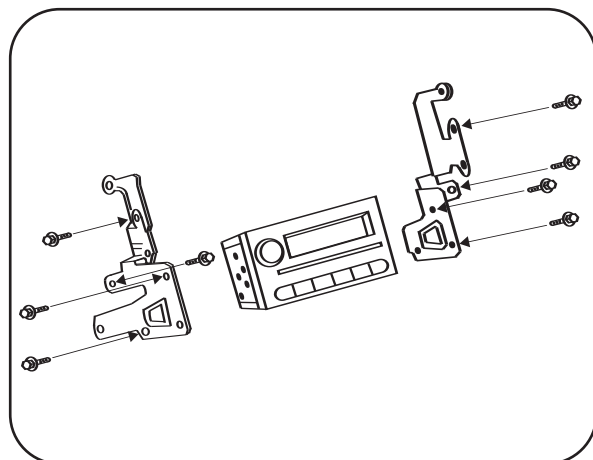

TOYOTA MATRIX 2005-2008

- 1 Disconnect the negative battery terminal to prevent an accidental short circuit.
- 2 Unclip the bottom edge of the radio trim panel then lift up and out to remove. (Figure A)
- 3 Remove (4) 10 MM bolts securing the factory radio. (Figure B)

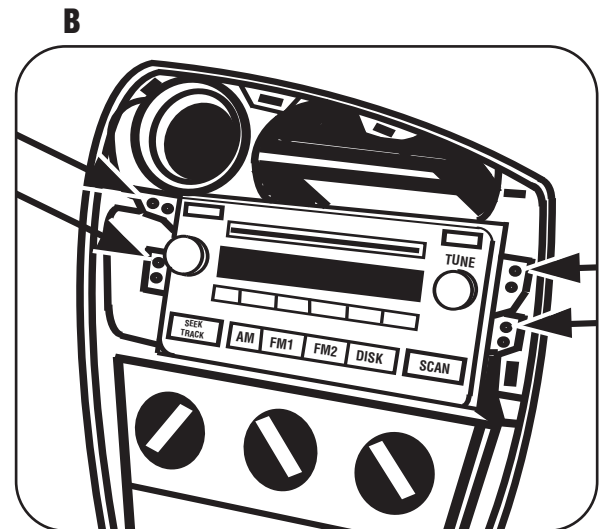
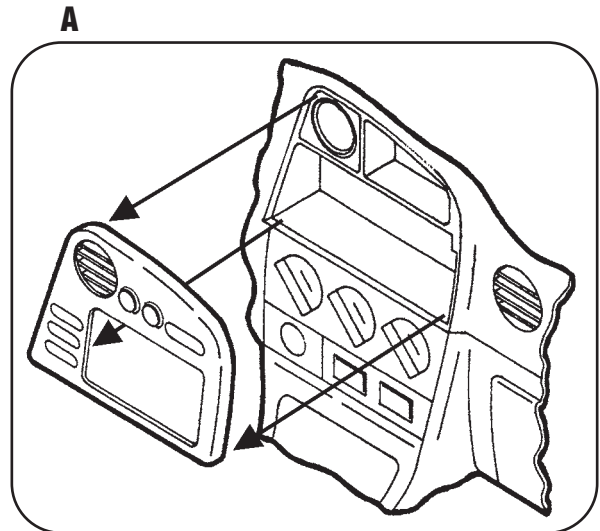

TOYOTA MATRIX 2009 **(WITH FACTORY NAVIGATION)**

- 1** Disconnect the negative battery terminal to prevent an accidental short circuit.

- 2** Unclip and remove the radio trim panel including the a/c vent. (Figure A)

- 3** Remove (4) 10 MM bolts securing the factory radio. Unplug and remove the radio. (Figure B)

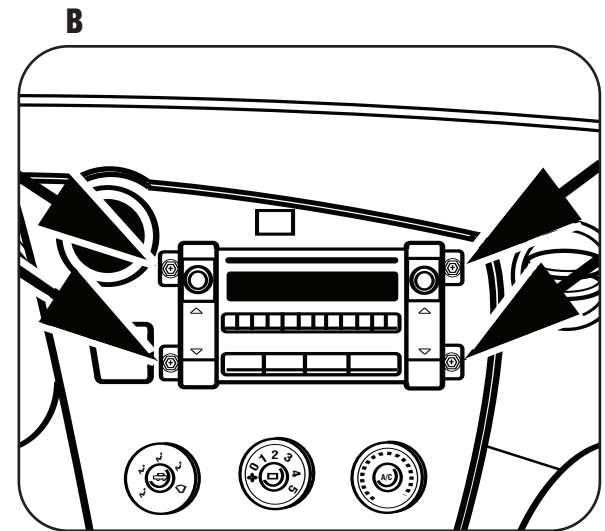
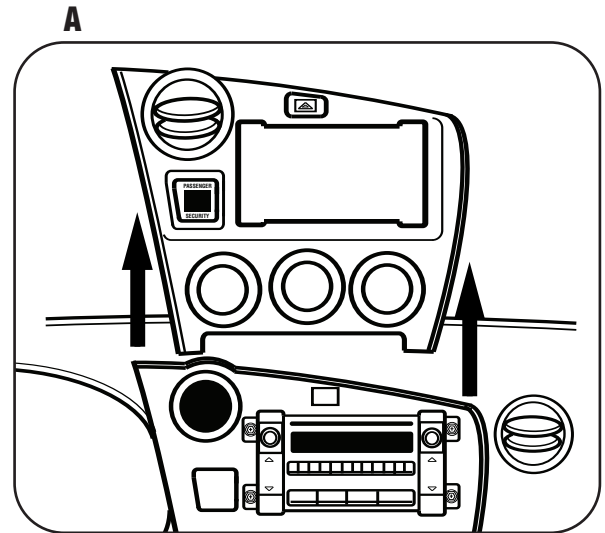

TOYOTA 4 RUNNER 2003-2009 (EXCLUDING LIMITED)

- 1 Disconnect the negative battery terminal to prevent an accidental short circuit.
- 2 Unsnap and remove trim from around shifter.
- 3 Unsnap and remove trim covers from around center console pocket edge at front and rear of console.
- 4 Unsnap and remove center console cover. (Figure A)
- 5 Unsnap trim ring from around ignition key cylinder.
- 6 Remove (1) 10 mm bolt from bottom right of panel below steering column. Unsnap panel and pull away to gain access behind panel. (Figure B)
- 7 Remove (1) 10 mm bolt on bottom left of center panel behind panel below steering column. (Figure B)
- 8 Remove (1) 10 mm bolt beneath climate control behind pocket door. Unsnap and remove climate control. (Figure C)
- 9 Remove (2) 10 mm bolts beneath radio behind climate controls.
- 10 Unsnap and remove entire center panel around radio. (Figure D)
- 11 Remove (2) 10 mm bolts securing radio.
- 12 Unplug and remove radio.
- 13 Remove factory brackets from radio. Retain brackets for use during kit assembly.
- 14 *Continue to kit assembly.*

A

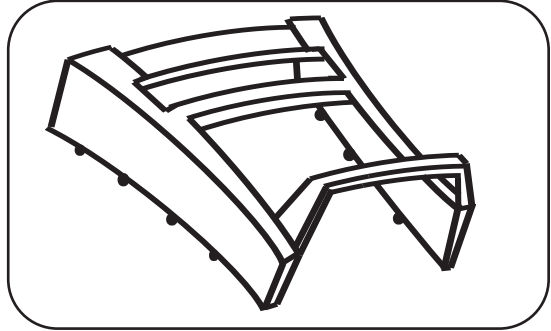

B

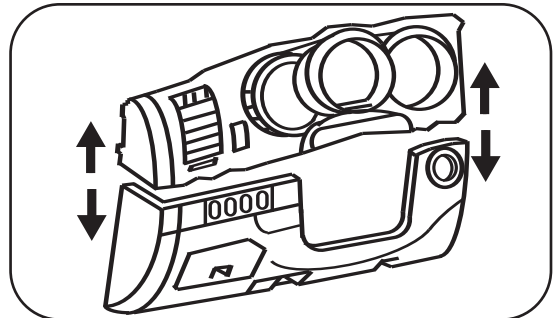

C

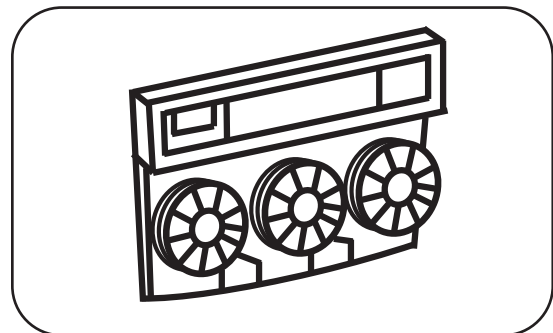

D

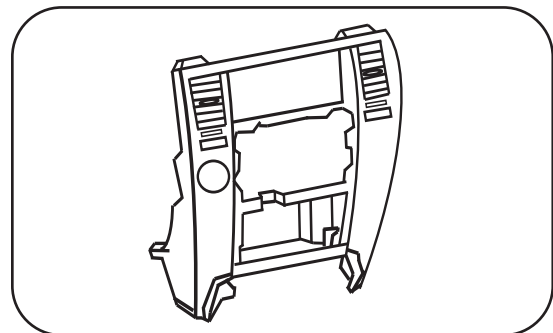

TOYOTA TUNDRA 2003-2006

- 1 Disconnect the negative battery terminal to prevent an accidental short circuit.
- 2 Remove the (3) climate control knobs by pulling straight outward. **(Figure A)**
- 3 Remove (3) Phillips screws from behind knobs. **(Figure A)**
- 4 Position vents facing upward and remove (1) Phillips screw from each A/C vent. **(Figure B)**
- 5 Unclip and remove entire trim panel. **(Figure C)**
- 6 Remove (4) 10 mm bolts to remove radio. **(Figure D)**
- 7 Unplug and remove radio.
- 8 Remove factory brackets from radio. Retain brackets for use during kit assembly.
- 9 *Continue to kit assembly.*

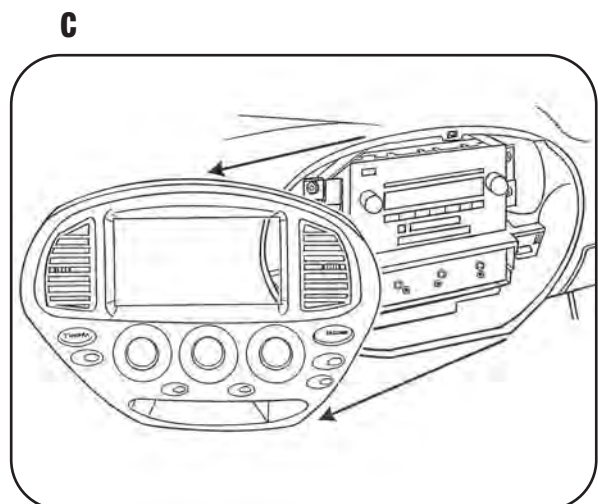
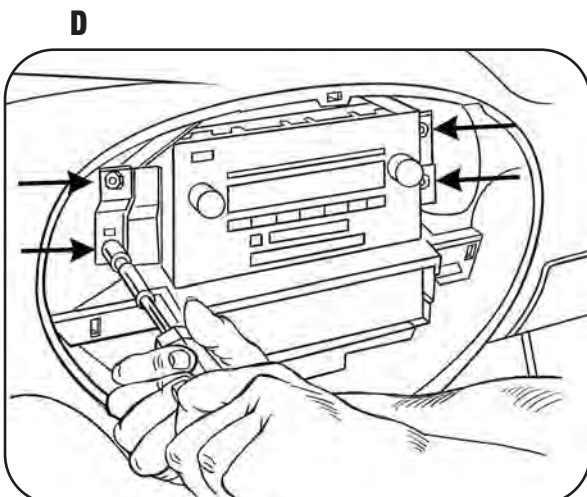
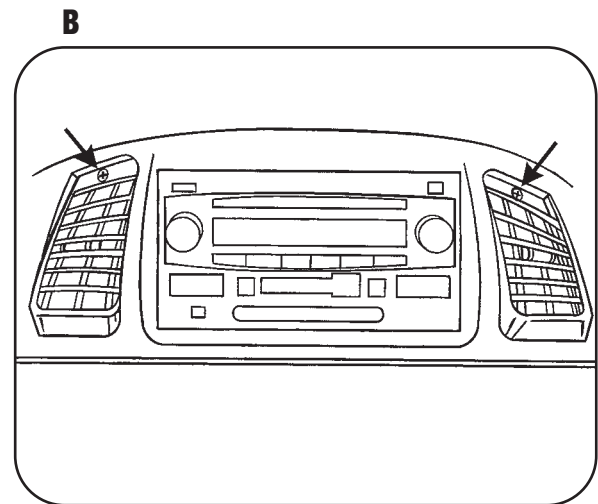
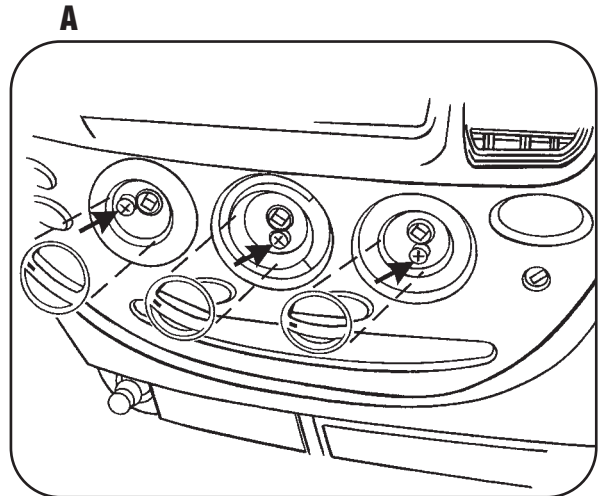

TOYOTA SEQUOIA 2003-2006

- 1** Disconnect the negative battery terminal to prevent an accidental short circuit.
- 2** Position vents facing upward and remove (1) Phillips screw from each A/C vent. **(Figure A)**
- 3** Unclip and remove entire radio trim panel including climate controls. **(Figure B)**
- 4** Remove (4) 10 mm bolts to remove radio. **(Figure C)**
- 5** Unplug and remove radio.
- 6** Remove factory brackets from radio. Retain brackets for use during kit assembly.
- 7** *Continue to kit assembly.*

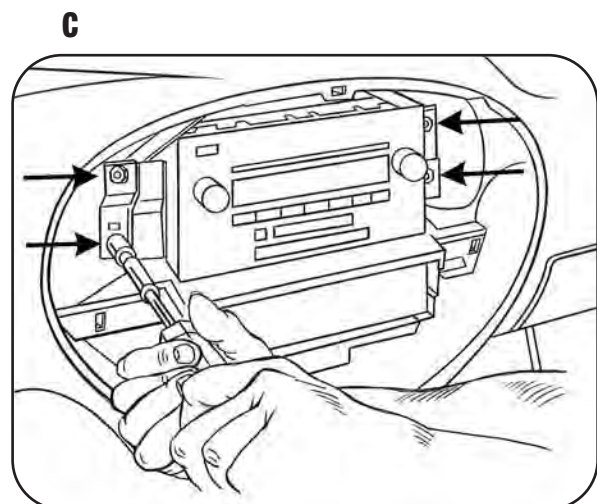
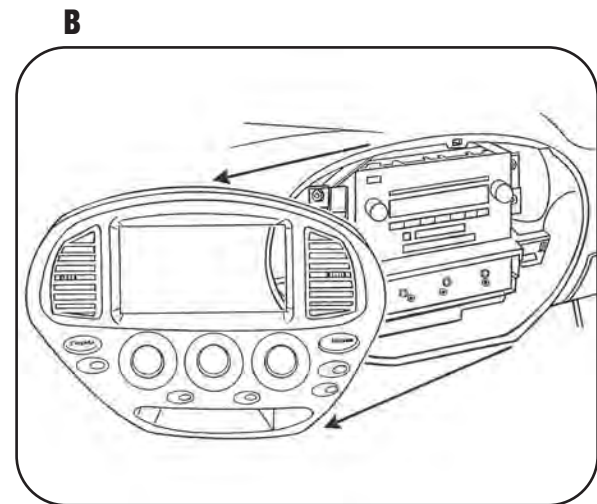
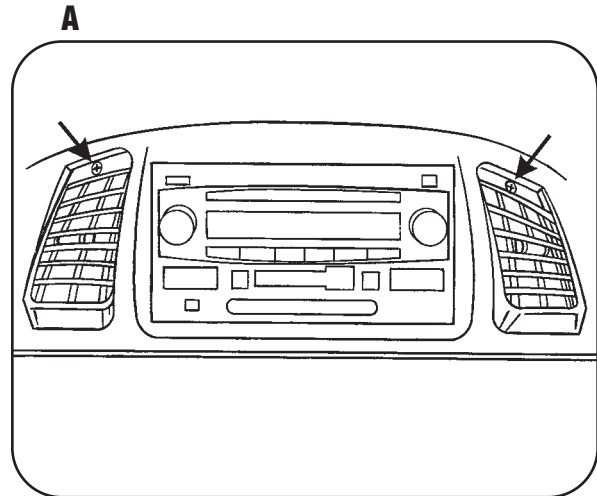

TOYOTA FJ CRUISER 2007-2009

- 1 Disconnect the negative battery terminal to prevent an accidental short circuit.
- 2 Remove two Phillips screws from bottom part of side trim panels. (Figure A)
- 3 Using a panel removal tool, carefully remove the side trim panels. (Figure B)
- 4 Remove (2) Phillips screws from radio trim panel. (Figure C)
- 5 Using panel removal tool, carefully remove radio trim panel. (Figure D)
- 6 Remove (4) 10mm bolts securing the radio.
- 7 Unplug and remove radio.
- 8 Remove factory brackets from radio. Retain brackets for use during kit assembly.
- 9 *Continue to kit assembly.*

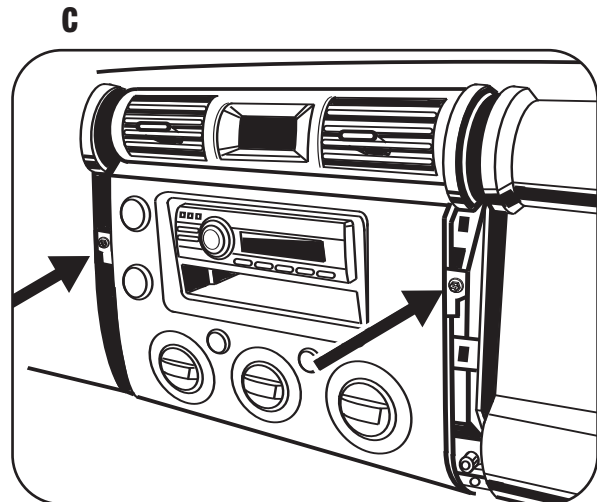
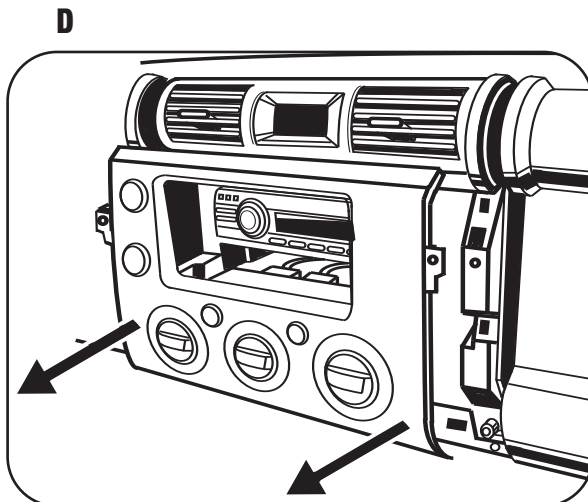
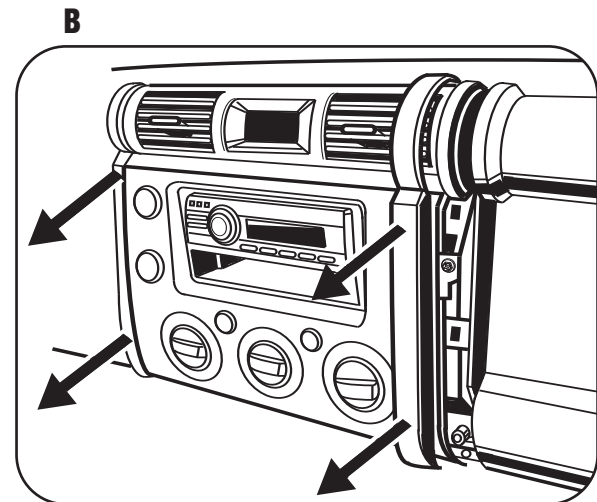
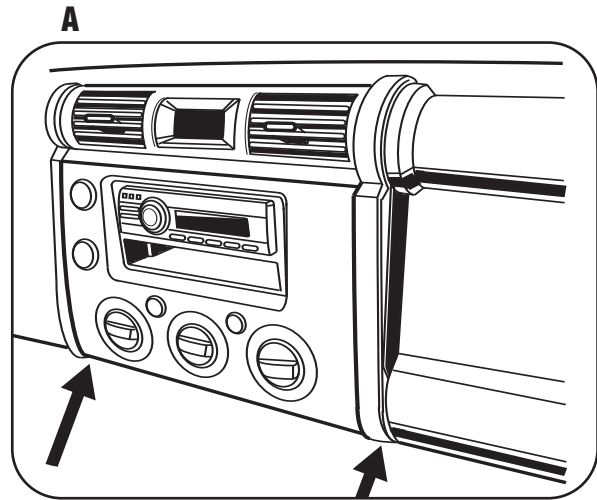

YARIS 2007-2009

- 1 Disconnect the negative battery terminal to prevent an accidental short circuit.
- 2 Unclip the bottom trim panel located underneath the A/C Controls. (Figure A)
- 3 Unclip the two side trim panels that surround the A/C Controls and Radio. (Figure A)
- 4 Unclip the Instrument trim Panel surrounding the Speedometer and gauges. (Figure B)
- 5 Unclip the Radio/AC Vents trim Panel. (Figure B)
- 6 Remove (4) Phillips screws securing radio. (Figure C)
- 7 Unplug and remove radio.
- 8 Remove (4) Phillips screws securing factory brackets on each side of the radio and remove brackets. Retain brackets for use during kit assembly. (Figure D)
- 9 *Continue to kit assembly.*

A

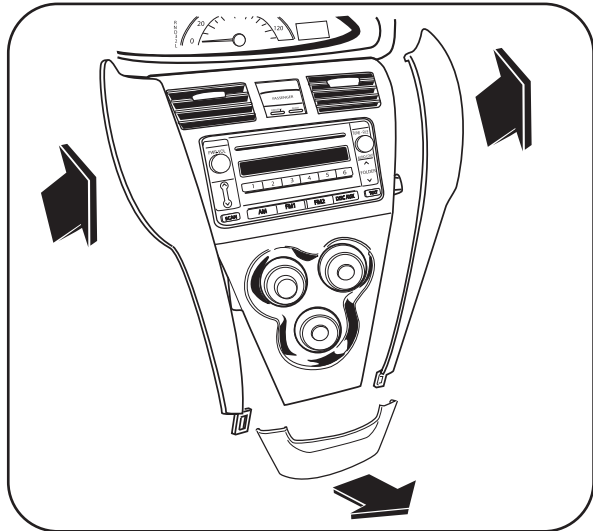

B

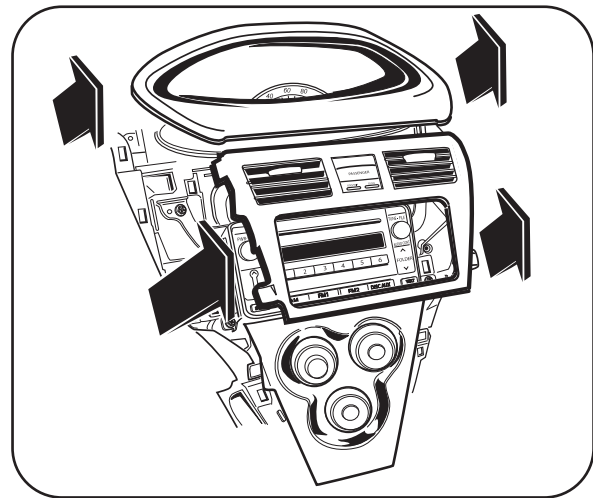

C

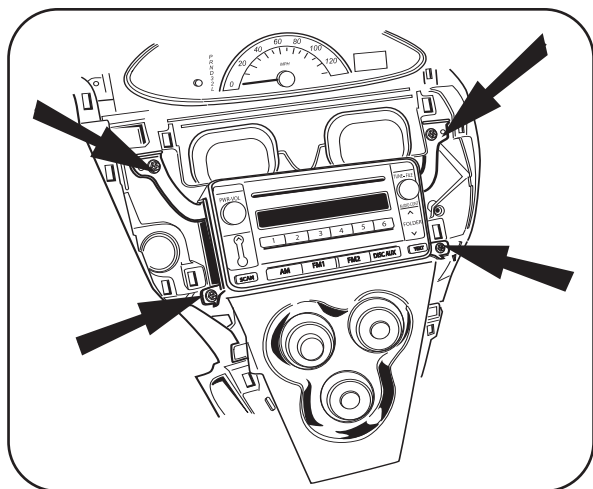

D

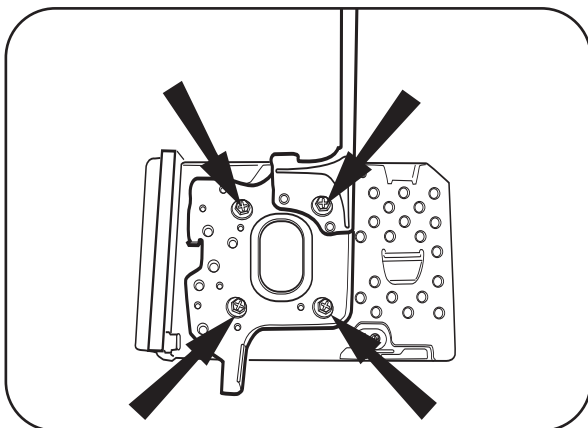

SCION XA 2004-2006

- 1 Disconnect the negative battery terminal to prevent an accidental short circuit.
- 2 Pull outward on the (3) climate control knobs and remove. (Figure A)
- 3 Remove (2) Phillips screws from behind the outer two climate knobs. (Figure B)
- 4 Unsnap and remove the trim pieces on each side of the climate control/ash-tray/pocket assembly. (Figure C)
- 5 Remove (2) phillips screws from the bottom of the climate control/radio trim panel and unsnap and remove the entire panel. (Figure D)
- 6 Remove (4) Phillips screws to remove the factory radio.
- 7 Remove factory brackets from radio. Retain brackets for use during kit assembly.
- 8 *Continue to kit assembly.*

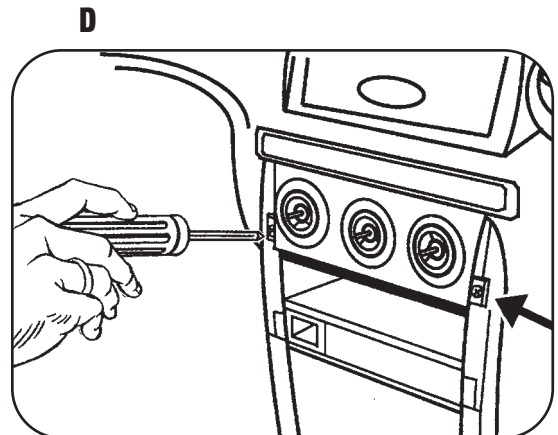
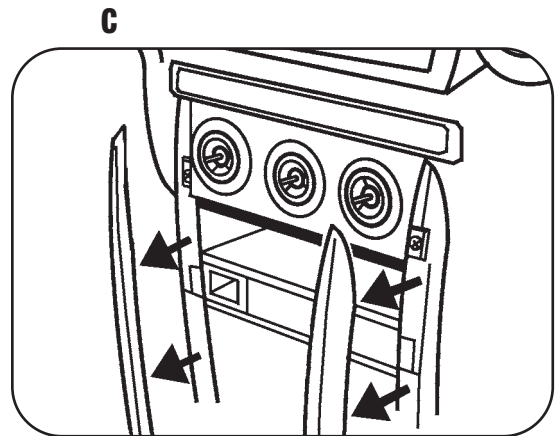
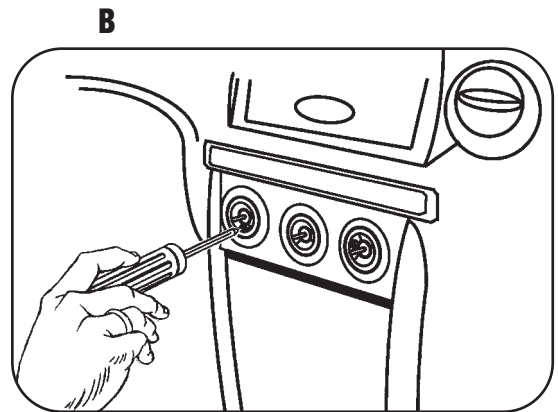
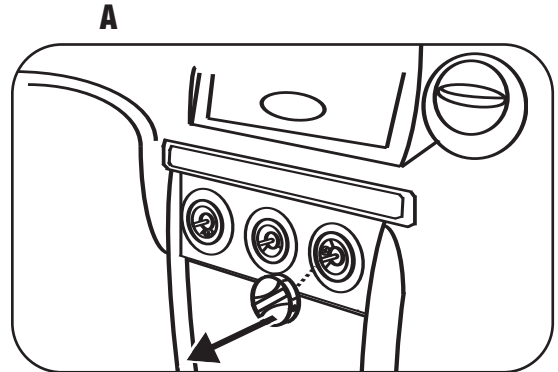

SCION XB 2004-2007

- 1** Disconnect the negative battery terminal to prevent an accidental short circuit.
- 2** Pull outward on the (3) climate control knobs and remove. (Figure A)
- 3** Remove (2) Phillips screws from behind the outer (2) knobs. (Figure B)
- 4** Unsnap and remove the entire panel surrounding the climate controls and the radio. (Figure C)
- 5** Remove (4) Phillips screws to remove the factory radio.
- 6** Remove factory brackets from radio. Retain brackets for use during kit assembly.
- 7** *Continue to kit assembly.*

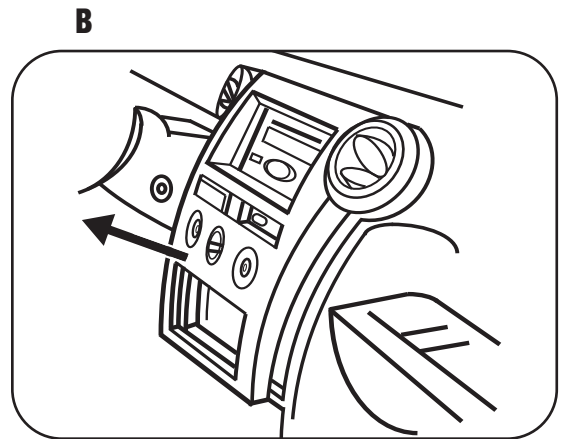
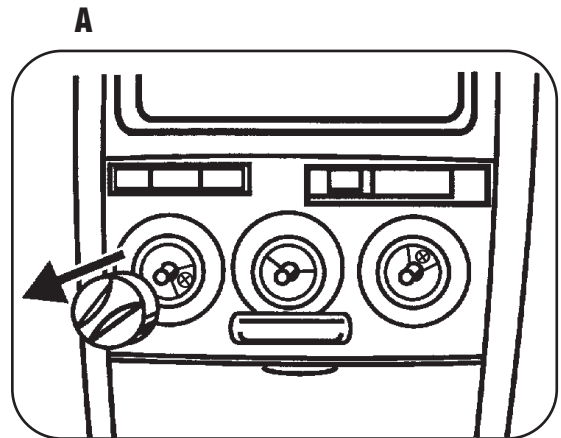

SCION XB 2008-2009

- 1 Unclip and remove the trim panel around the radio including the a/c vents. (Figure A)
- 2 Unclip and remove the trim panel at the bottom edge of the dash cavity. (Figure B)
- 3 Remove (4) 10 MM bolts securing the radio. (Figure C)

Continue to kit assembly.

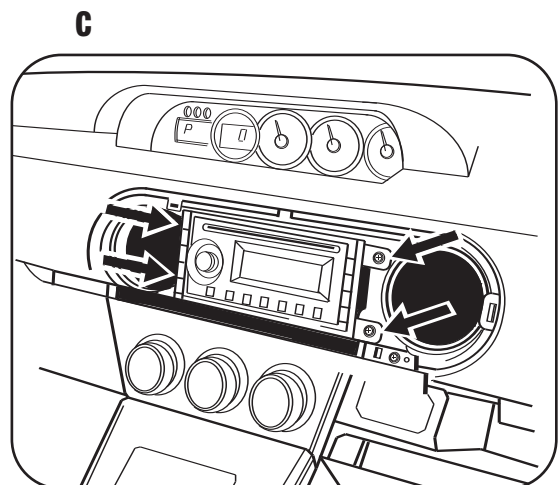
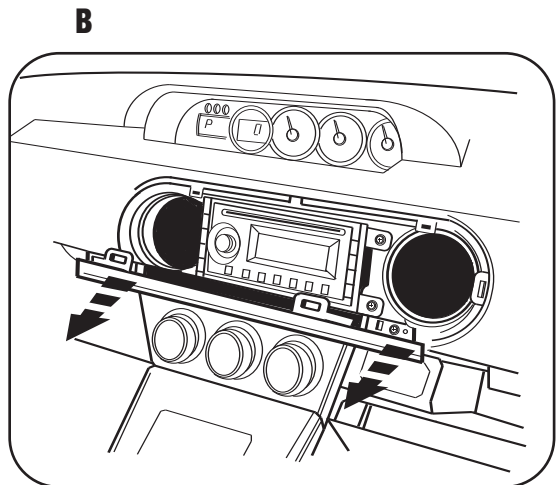
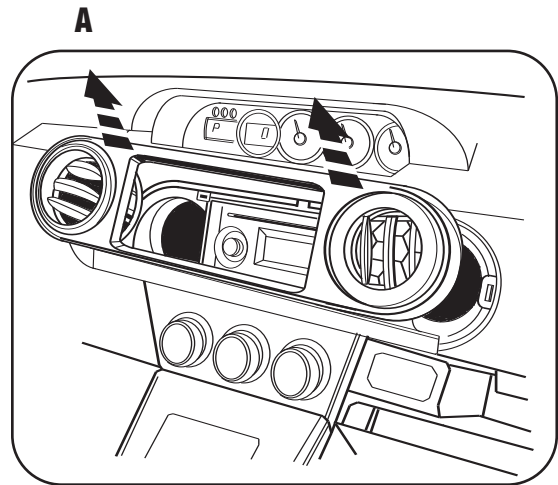

SCION TC 2005-2009

- 1** Disconnect the negative battery terminal to prevent an accidental short circuit.
- 2** Unsnap trim from around shifter (not necessary to be removed). (Figure A)
- 3** Unclip and remove panel from around radio. (Including climate controls and radio door). (Figure B)
- 4** Remove (2) 10mm nuts from the top mounting locations and (2) 10mm bolts from the bottom mounting locations to remove the radio. (Figure C)
- 5** Remove factory brackets from radio. Retain brackets for use during kit assembly.
- 6** *Continue to kit assembly.*

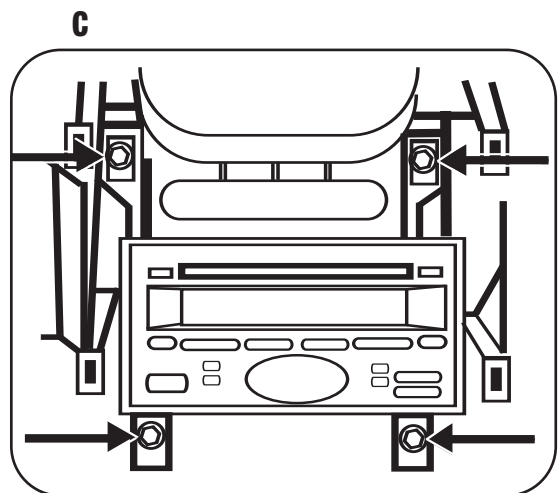
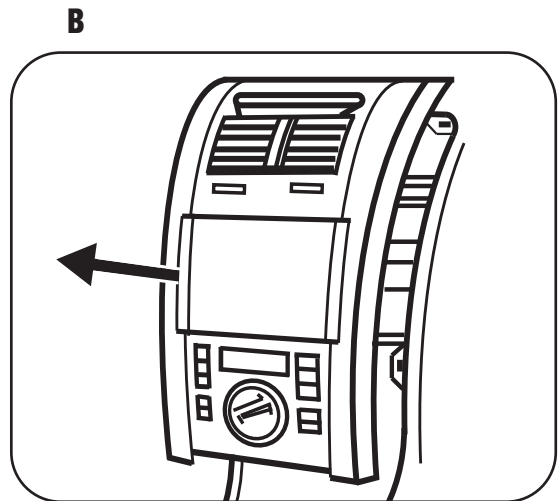
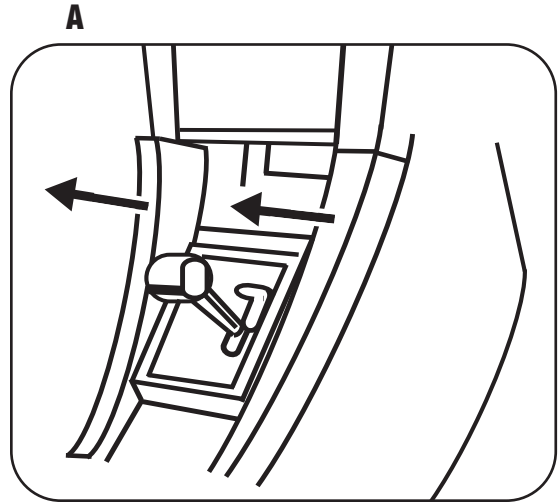

SCION XD 2008-2009

- 1** Disconnect the negative battery terminal to prevent an accidental short circuit.
- 2** Unclip radio trim panel. Unplug and remove panel. (Figure A)
- 3** Remove (4) Phillips screws securing the radio. Unplug and remove radio. (Figure B)
- 4** Remove factory brackets from radio. Retain brackets for use during kit assembly. (Figure C)

Continue to kit assembly.

A

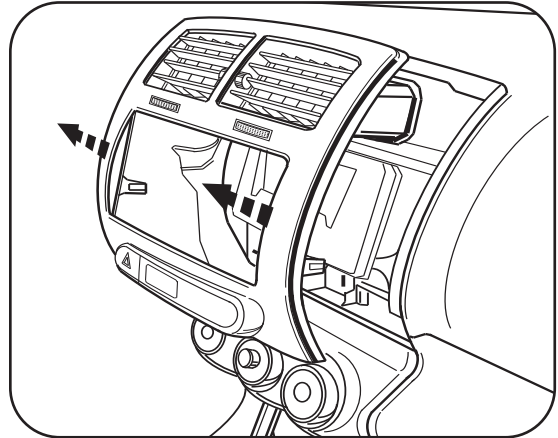

B

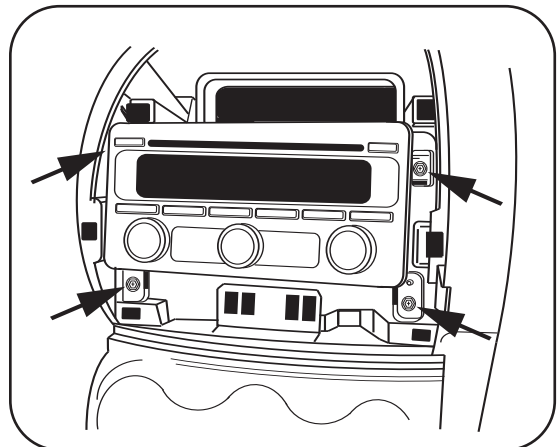

C

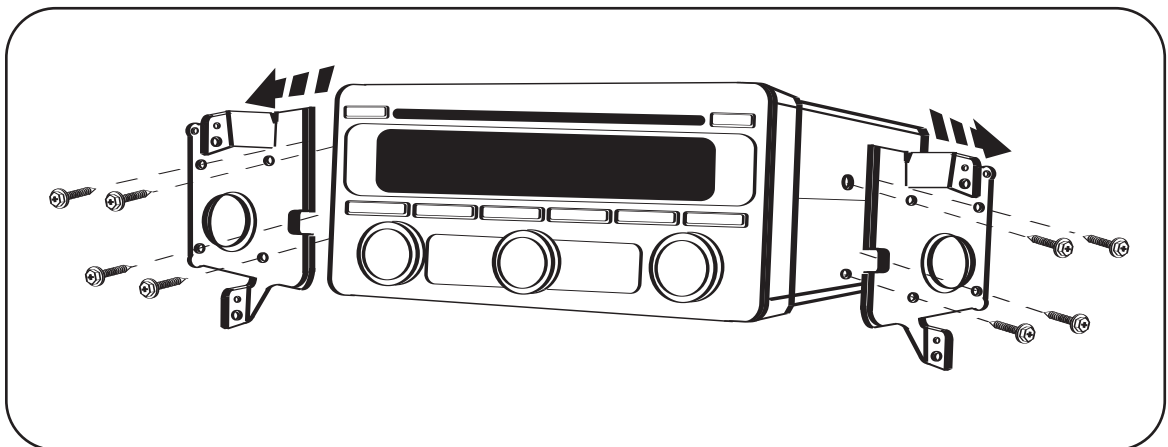

NOTE: For all Scion TC and XA you will need to cut off the front upper section of the DDIN trim plates, as shown by dotted lines labeled “A” in (Figure A).

For the 2001-2006 Toyota Rav 4, the 2001-2006 Toyota Highlander, and the 2003-2006 Toyota Sequoia/Tundra you will need to cut off the rear section of the DDIN trim plates, as shown by dotted lines labeled “B” in (Figure A).

For all other vehicles skip to Step 1.

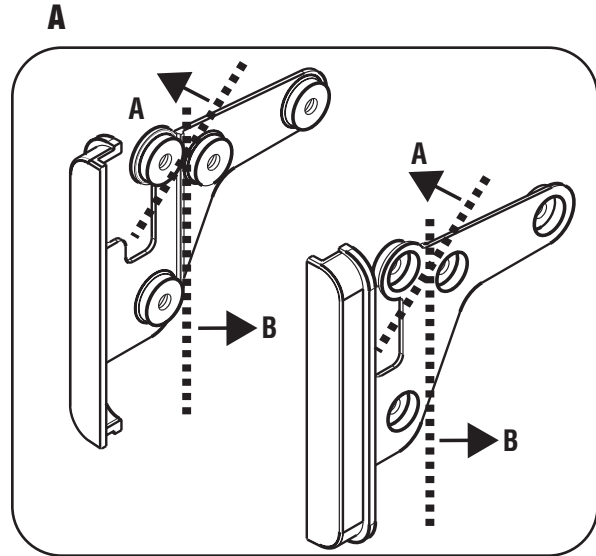

DOUBLE DIN HEAD UNIT PROVISION

- 1 Attach the factory mounting brackets and the 95-8202 DDIN trim plates to the DDIN head unit with the screws supplied with the unit. (Figure B)

NOTE: Remove locating pins from factory brackets with grinder.

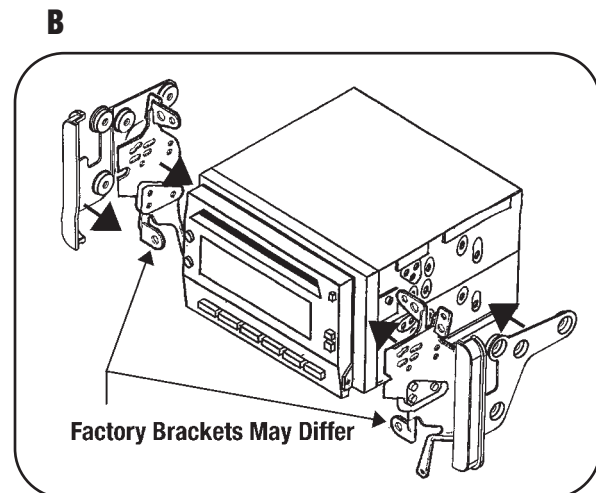

STACKED ISO HEAD UNIT PROVISION

- 1 Attach the factory mounting brackets and the 95-8202 DDIN trim plates to the stacked ISO DIN head units with the screws supplied with the units. (Figure C) **NOTE:** Remove locating pins from factory brackets with grinder.

Continue to final assembly.

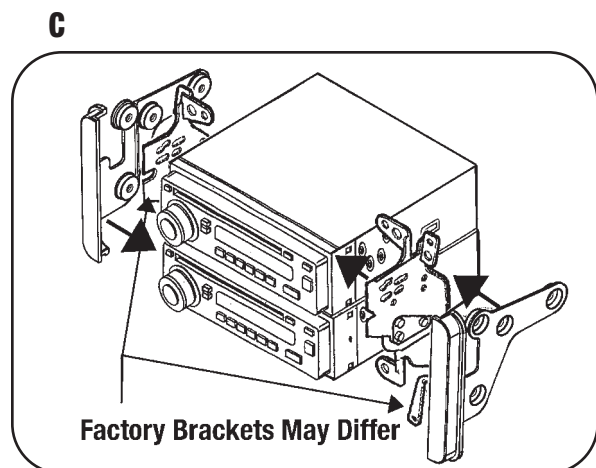

FINAL ASSEMBLY

- 1 Locate the factory wiring harness in the dash and make the connection as shown. Metra recommends using the proper mating adapter and making the connections as shown. (Isolate and individually tape off the ends of any unused wires to prevent electrical short circuit.)
- 2 Re-connect the negative battery terminal and test the unit for proper operation.
- 3 Reassemble radio and dash assemblies in reverse order of disassembly.

FINAL WIRING CONNECTIONS

Make wiring connections using the EIA color code chart shown below and the instructions included with the head unit. Metra recommends making connections as shown below; Strip, Splice, Solder, Tape. Isolate and individually tape off ends of any unused wires to prevent electrical short circuit.

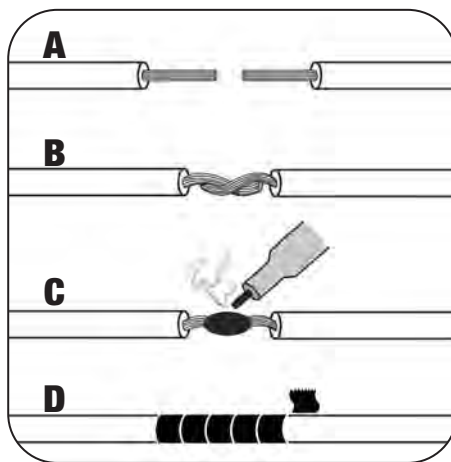

- A) Strip wire ends back 1/2"**
- B) Twist ends together**
- C) Solder**
- D) Tape**

METRA / EIA WIRING CODE

12V Ignition / Acc . . . Red	Right Front (+) Gray
12V Batt / Memory . . Yellow	Right Front (-) Gray / Black
Ground Black*	Left Front (+) White
Power Antenna Blue	Left Front (-) White / Black
Amp Turn-On Blue / White	Right Rear (+) Violet
Amp Ground Black / White	Right Rear (-) Violet / Black
Illumination Orange	Left Rear (+) Green
Dimmer Orange / White	Left Rear (-) Green / Black

***NOTE:** When a Black wire is not present, ground radio to vehicle chassis.

All colors may not be present on all leads due to manufacturer's specifications.

95-8202 INSTRUCTIONS



KNOWLEDGE IS POWER

Enhance your installation and fabrication skills by enrolling in the most recognized and respected mobile electronics school in our industry. Log onto www.installerinstitute.com or call 800-354-6782 for more information and take steps toward a better tomorrow.



1-800-221-0932



www.metraonline.com

REV. 06/03/09

© COPYRIGHT 2004-2009 METRA ELECTRONICS CORPORATION

INST95-8202