



INSTALLATION INSTRUCTIONS FOR PART 95-8203

APPLICATIONS 2002-2006 Toyota Camry

95-8203

KIT FEATURES

- DDIN Head Unit Provision
- Stacked ISO DIN Head Unit Provision



KIT COMPONENTS

A) DDIN Trim Plate B) (12) ISO Screws

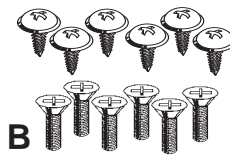
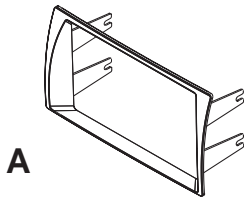

TOOLS REQUIRED:

Phillips Screwdriver • Socket Wrench

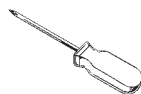

1-800-221-0932



www.metraonline.com

© COPYRIGHT 2004 METRA ELECTRONICS CORPORATION



TABLE OF CONTENTS

Dash Disassembly

- 2002-2006 Toyota Camry 1

Kit Assembly

- DDIN Head Unit Provision 2

- Stacked ISO Head Unit Provision 2

Final Assembly 3

2002-2006 TOYOTA CAMRY

- 1** Disconnect the negative battery terminal to prevent an accidental short circuit.
- 2** Unclip and remove the climate control trim panel. (Figure A)
- 3** Unclip and remove the radio trim panel including the climate control vents. (Figure B)
- 4** Remove (4) 10 MM bolts securing the radio. Unplug wiring and remove radio.
- 5** Remove factory brackets and use on kit assembly. (Figure C)

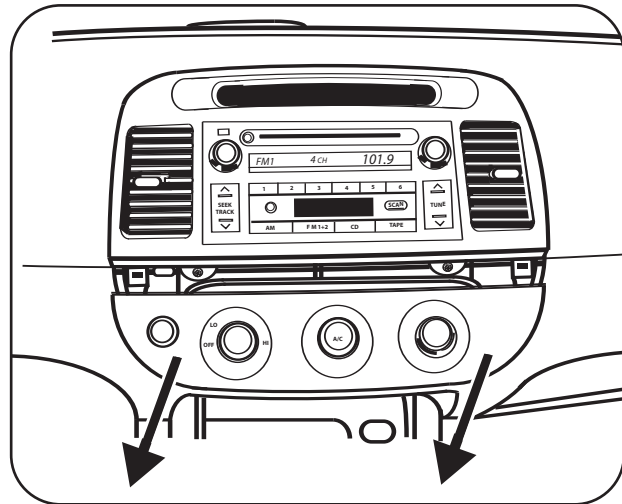
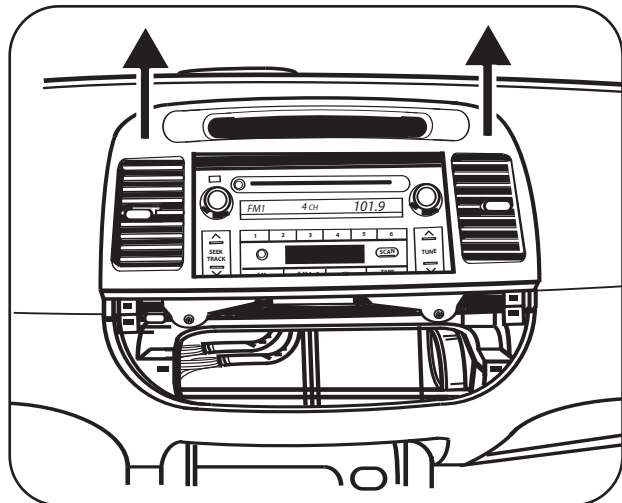
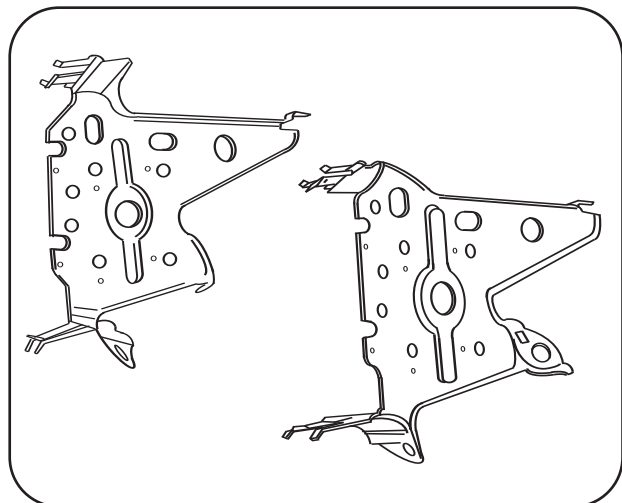
A**B****C**

DDIN HEAD UNIT PROVISION

- 1 Position radio in DDIN trimplate and attach factory radio brackets with supplied ISO screws. (Figure A)

Note: Two different thread type screws have been provided to fit most aftermarket radios.

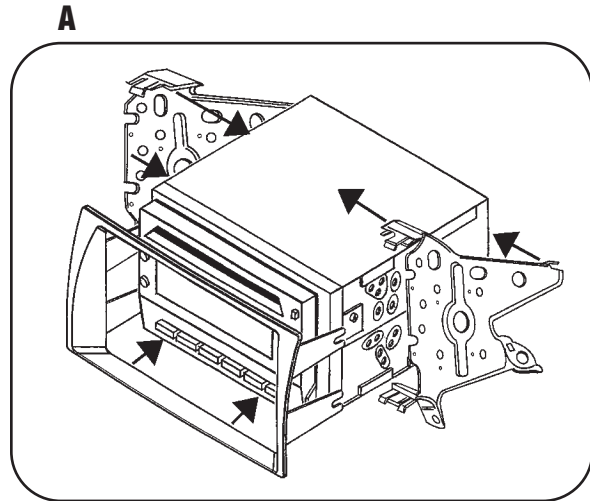

STACKED ISO HEAD UNIT PROVISION

- 1 Position radios in DDIN trimplate and attach factory radio brackets with supplied ISO screws. (Figure A)

Note: Two different thread type screws have been provided to fit most aftermarket radios.

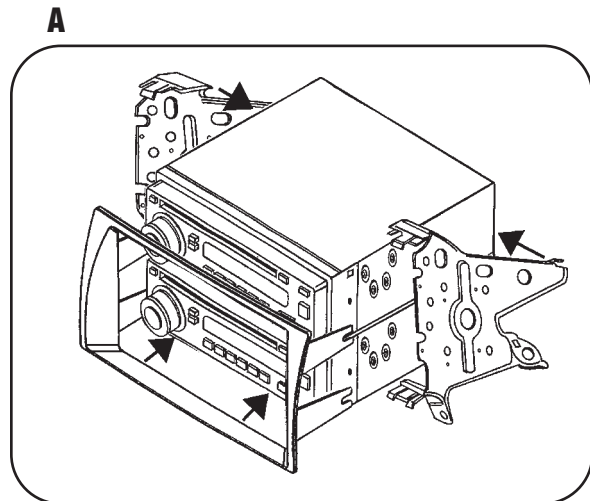

FINAL ASSEMBLY

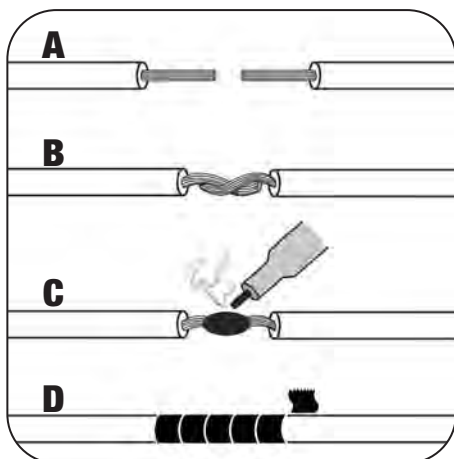

- A) Strip wire ends back 1/2"**
- B) Twist ends together**
- C) Solder**
- D) Tape**

- 1** Locate the factory wiring harness in the dash. Metra recommends using the proper mating adapter and making connections as shown. (Isolate and individually tape off the ends of any unused wires to prevent electrical short circuit.)
- 2** Re-connect the negative battery terminal and test the unit for proper operation.
- 3** Reassemble radio and dash assemblies in reverse order of disassembly.

FINAL WIRING CONNECTIONS

Make wiring connections using the EIA color code chart shown below and the instructions included with the head unit. Metra recommends making connections as shown below; Strip, Splice, Solder, Tape. Isolate and individually tape off ends of any unused wires to prevent electrical short circuit.

METRA / EIA WIRING CODE

12V Ignition / Acc . . . Red	Right Front (+) Gray
12V Batt / Memory . . Yellow	Right Front (-) Gray/ Black
Ground Black*	Left Front (+) White
Power Antenna Blue	Left Front (-) White / Black
Amp Turn-On Blue / White	Right Rear (+) Violet
Amp Ground Black / White	Right Rear (-) Violet / Black
Illumination Orange	Left Rear (+) Green
Dimmer Orange / White	Left Rear (-) Green / Black

***NOTE:** When Black a wire is not present, ground radio to vehicle chassis.
All colors may not be present on all leads due to manufacturer's specifications.

95-8203 INSTRUCTIONS



1-800-221-0932



www.metraonline.com

REV. 03/31/06

© COPYRIGHT 2004 METRA ELECTRONICS CORPORATION

INST95-8203