



INSTALLATION INSTRUCTIONS FOR PART 95-8210

APPLICATIONS Toyota 4-Runner Limited 2003-2009

95-8210

KIT FEATURES

- Double DIN Radio Provision
- Stacked ISO Mount Units Provision

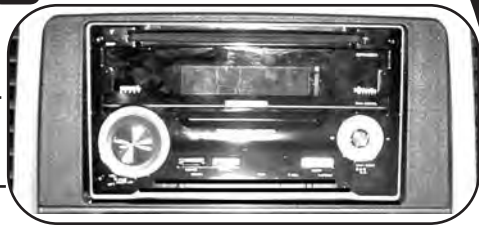

KIT COMPONENTS

- A) Double Din Trim Plate • B) Double DIN Brackets

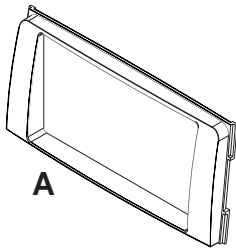

WIRING AND ANTENNA CONNECTIONS (Sold Separately)

Wiring Harness:

- 70-1761 - Toyota harness 1987-up
- TYTO-01 - Toyota amp harness 2003-UP

Antenna Adapter:

- Not required

TOOLS REQUIRED:

Small Flat Blade Screwdriver/ Panel Removal Tool

- Phillips Screwdriver • Socket Set



1-800-221-0932



www.metraonline.com

© COPYRIGHT 2007-2009 METRA ELECTRONICS CORPORATION

TABLE OF CONTENTS

Dash Disassembly

- Toyota 4-Runner Limited 2003-2009 1,2

Kit Assembly

- Double DIN Radio Provision ... 3

- Stacked ISO Mount Units Provision 4

Final Assembly 5

***Note:**

Refer also to the instructions included with the aftermarket radio.



KNOWLEDGE IS POWER

Enhance your installation and fabrication skills by enrolling in the most recognized and respected mobile electronics school in our industry.

Log onto www.installerinstitute.com or call 800-354-6782 for more information and take steps toward a better tomorrow.

Toyota 4-Runner Limited 2003-2009

- 1 Disconnect the negative battery terminal to prevent an accidental short circuit.
- 2 Unsnap and remove trim from around shifter. (Figure A)
- 3 Unsnap and remove center console cover. (Figure B)
- 4 Unsnap trim ring from around ignition key cylinder.
- 5 Remove (1) 10 mm bolt from bottom right side of panel below steering column. Unsnap panel and pull away to gain access behind panel. (Figure C)
- 6 Remove (1) 10 mm bolt on bottom left of center panel behind panel below steering column. (Figure D)

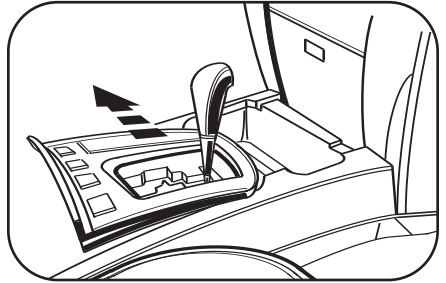
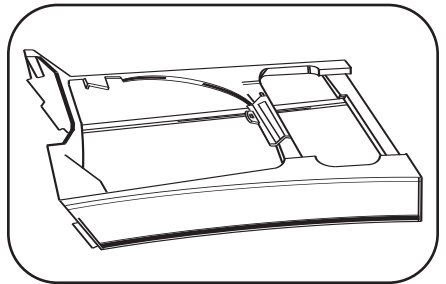
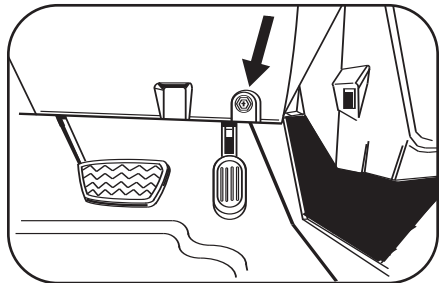
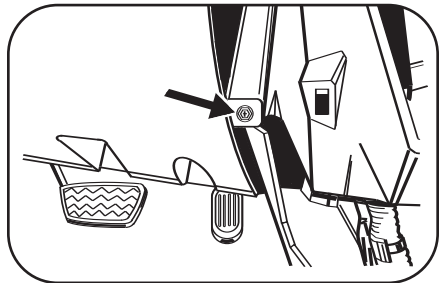
A

B

C

D

Toyota 4-Runner Limited 2003-2009

7 Remove (1) 10 mm bolt beneath climate control behind pocket door. (Figure E) Unsnap climate control, unplug and remove climate control. (Figure F)

8 Remove (2) 10 mm bolts beneath radio behind climate controls. (Figure G)

9 Unsnap and remove entire center panel around radio.

10 Remove (2) 10 mm bolts securing radio. Unplug and remove radio. (Figure H)

Continue to final assembly.

E

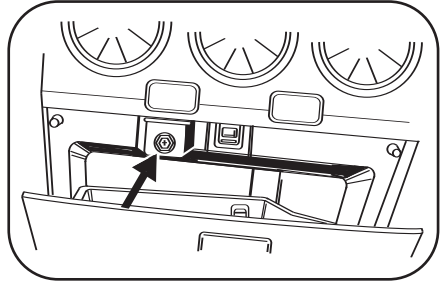

F

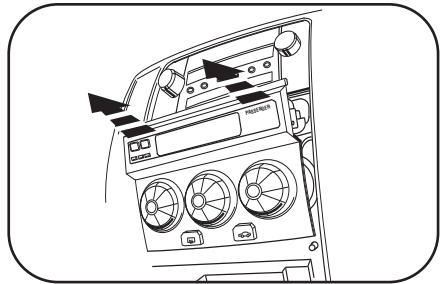

G

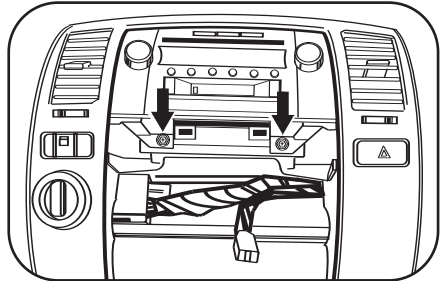

H

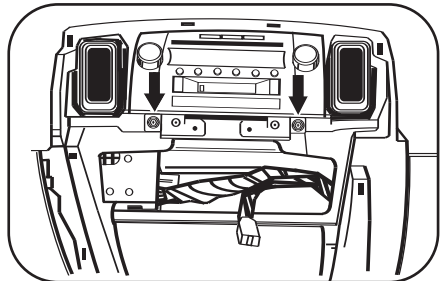

DOUBLE DIN RADIO PROVISION

**Note: Refer also to the instructions included with the aftermarket radio.*

- 1 Snap the factory brackets to the side of the radio. (Figure A)
- 2 Snap the Double DIN brackets to the outside edge of the Double DIN trim plate. (Figure B)
- 3 Slide the Double DIN radio into the bracket/trim plate assembly and secure the radio to the assembly using the screws supplied with the radio. (Figure C)

Continue to final assembly.

A

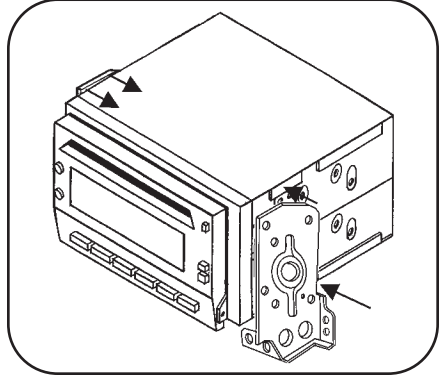

B

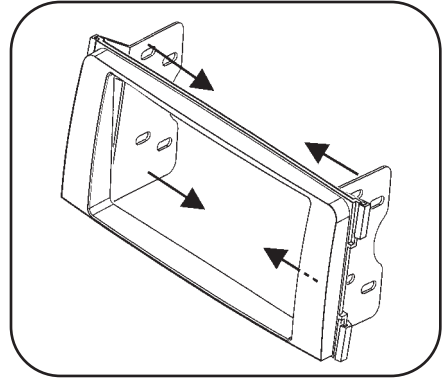

C

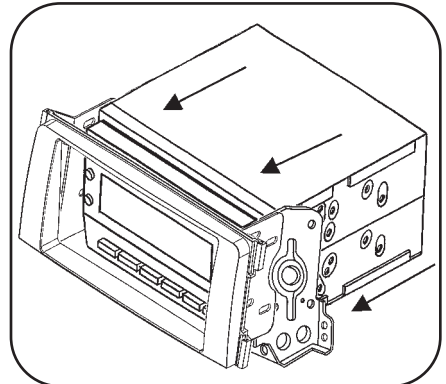

STACKED ISO UNITS PROVISION

**Note: Refer also to the instructions included with the aftermarket radio.*

- 1 Snap the factory brackets to the side of the radio. (Figure A)
- 2 Snap the Double DIN brackets to the outside edge of the Double DIN trim plate. (Figure B)
- 3 Slide the stacked ISO mount units into the bracket/trim plate assembly and secure the units to the assembly using the screws supplied with the units. (Figure C)

Continue to final assembly.

A

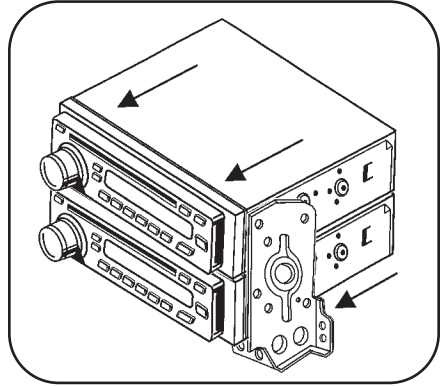

B

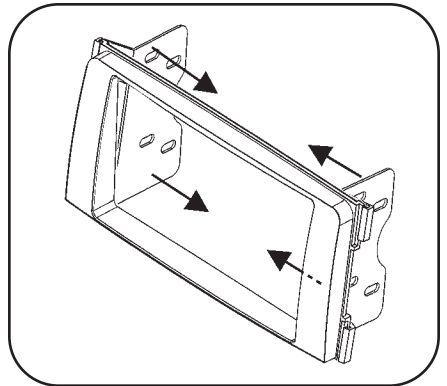

C

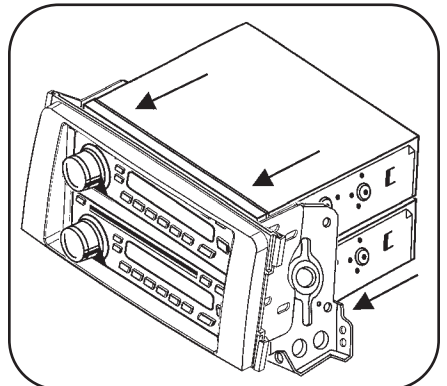

FINAL ASSEMBLY

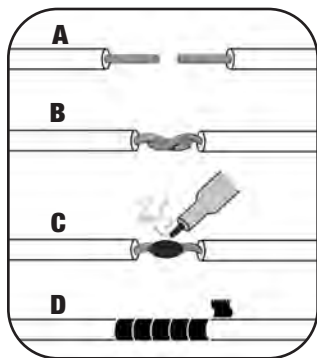

(A) Strip wire ends back 1/2"

(B) Twist ends together

(C) Solder

(D) Tape

- 1** Locate the factory wiring harness in the dash. Metra recommends using the proper mating adapter and making connections as shown. (Isolate and individually tape off the ends of any unused wires to prevent electrical short circuit.)
- 2** Re-connect the negative battery terminal and test the unit for proper operation.
- 3** Reassemble radio and dash assemblies in reverse order of disassembly.

FINAL WIRING CONNECTIONS

Make wiring connections using the EIA color code chart shown below and the instructions included with the head unit. Metra recommends making connections as shown below; Strip, Splice, Solder, Tape. Isolate and individually tape off ends of any unused wires to prevent electrical short circuit.

METRA / EIA WIRING CODE

12V Ignition / Acc. Red	Right Front (+) Gray
12V Batt / Memory. Yellow	Right Front (-). Gray/ Black
Ground. Black*	Left Front (+) White
Power Antenna. Blue	Left Front (-). White / Black
Amp Turn-On Blue / White	Right Rear (+) Violet
Amp Ground. Black / White	Right Rear (-) Violet / Black
Illumination Orange	Left Rear (+) Green
Dimmer Orange / White	Left Rear (-) Green / Black

***NOTE:** When a Black wire is not present, ground radio to vehicle chassis.

All colors may not be present on all leads due to manufacturer's specifications.

95-8210 INSTRUCTIONS



1-800-221-0932



www.metraonline.com

REV. 06/03/09 © COPYRIGHT 2004-2009 METRA ELECTRONICS CORPORATION INST95-8210