



## INSTALLATION INSTRUCTIONS FOR PART 95-8903B

### APPLICATIONS

### SUBARU

### LEGACY & OUTBACK

### 2010

**(NON-NAVIGATION RADIOS ONLY)**

# 95-8903B

#### KIT FEATURES

- DDIN radio provision with pocket
- Stacked ISO radio provision with pocket
- Painted scratch resistant matte black



#### KIT COMPONENTS

A) DDIN Trim plate B) DDIN Brackets

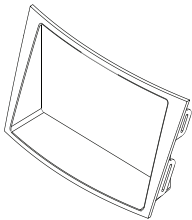

A

B

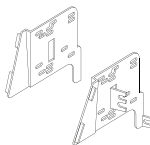

#### WIRING AND ANTENNA CONNECTIONS (Sold Separately)

##### Wiring Harness:

- 70-8901 Subaru Harness 1990-Up
- 70-7552 Nissan Harness 2007-Up

##### Antenna Adapter:

- 40-SB10 Subaru Antenna Adapter 2005-Up

#### TOOLS REQUIRED:

- Small Flat Blade Screwdriver
- Phillips Screwdriver
- Panel Removal Tool
- Socket Wrench

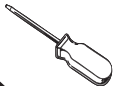

METRA. THE WORLD'S BEST KITS.™



1-800-221-0932



www.metraonline.com

© COPYRIGHT 2007-2009 METRA ELECTRONICS CORPORATION



**TABLE OF CONTENTS**

**Dash Disassembly**

- 2010 Subaru Legacy ..... 1

- 2010 Subaru Outback ..... 1

**Kit Assembly**

- Double DIN / Stacked ISO DIN Head Unit Provision. .... 2

**\*Note:**

**Refer also to the instructions included with the aftermarket radio.**



**KNOWLEDGE IS POWER**

Enhance your installation and fabrication skills by enrolling in the most recognized and respected mobile electronics school in our industry. Log onto [www.installerinstitute.com](http://www.installerinstitute.com) or call 800-354-6782 for more information and take steps toward a better tomorrow.



Metra recommends MECP certified technicians.

**2010 SUBARU LEGACY / OUTBACK**

- 1** Disconnect the negative battery terminal to prevent an accidental short circuit.
- 2** Unclip and remove the radio trim panel including the a/c vents. (Figure A)
- 3** Remove (4) Phillips screws securing the factory radio.

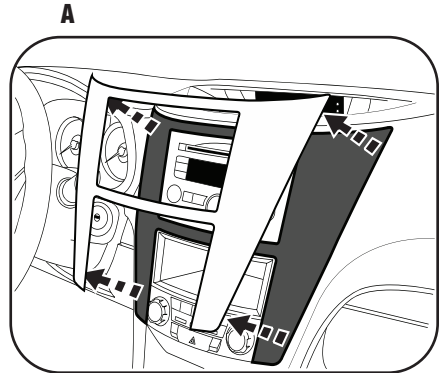

## **2010 SUBARU LEGACY / OUTBACK**

### **DOUBLE DIN / STACKED ISO DIN HEAD UNIT PROVISIONS**

- 1** Locate the factory wiring harness in the dash. Metra recommends using the proper mating adapter from Metra or AXCESS. Re-connect the negative battery terminal and test the unit for proper operation.
- 2** Attach the Double DIN brackets to the Double DIN trim plate. (Figure A)
- 3** Slide the Double DIN head unit or stacked ISO head units into the bracket/radio housing assembly and secure the Double DIN head unit or stacked ISO head units to the assembly using the screws supplied with the radio. (Figure B)
- 4** Reassemble dash in reverse order of disassembly.

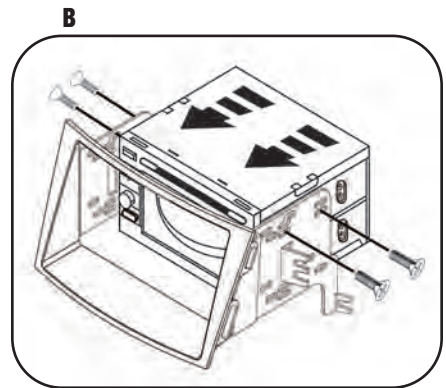
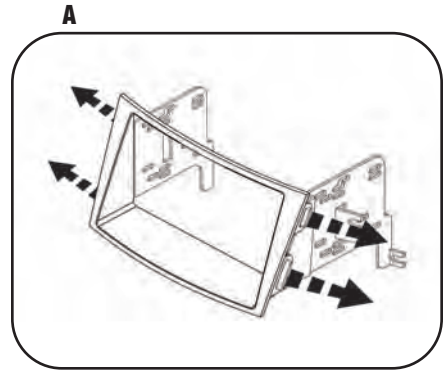



**NOTES**

---

---

---

---

---

---

---

---

---

---





# 95-8903B INSTRUCTIONS

METRA. THE WORLD'S BEST KITS.™



1-800-221-0932



[www.metraonline.com](http://www.metraonline.com)

REV. 12/18/09 © COPYRIGHT 2003-2009 METRA ELECTRONICS CORPORATION INST95-8903B