



INSTALLATION INSTRUCTIONS FOR PART 99-2006

APPLICATIONS

Cadillac CTS 2003-2007

Cadillac SRX 2004-2006

**99-2006/
99-2006G**

KIT FEATURES

- DIN Radio Provision with Pocket
- ISO Mount Radio Provision with Pocket
- Double DIN Radio Provision
- Stacked ISO Mount Units Provision
- Stacked DIN Head Units Provision
- Painted To Match Factory Dash

99-2006 = BLACK

99-2006G = GRAY



KIT COMPONENTS

- A) Radio Housing • B) DDIN Brackets • C) DDIN Trim Plate • D) ISO Brackets • E) Trim Plate • F) (8) Phillips screws
• (G) Pocket

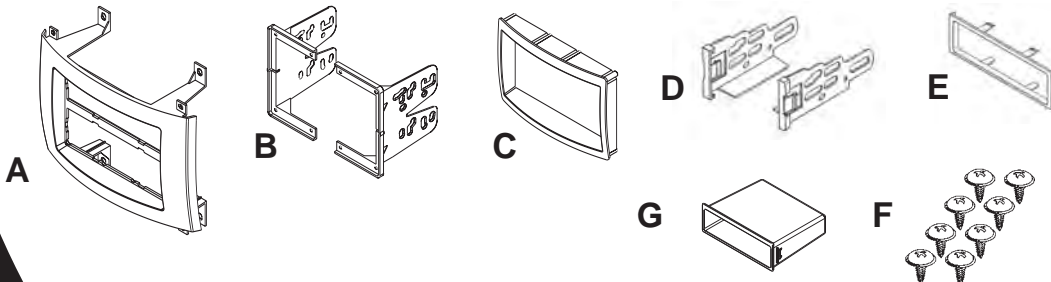

TOOLS REQUIRED:

- Phillips Screwdriver • Small Flat Blade Screwdriver • Socket Wrench

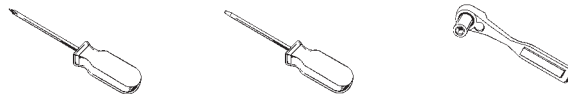

1-800-221-0932



www.metraonline.com

© COPYRIGHT 2004-2008 METRA ELECTRONICS CORPORATION



TABLE OF CONTENTS

***Dash Disassembly* 1**

***Kit Assembly*2, 3, 4**

***Final Assembly* 5**



KNOWLEDGE IS POWER

Enhance your installation and fabrication skills by enrolling in the most recognized and respected mobile electronics school in our industry. Log onto www.installerinstitute.com or call 800-354-6782 for more information and take steps toward a better tomorrow.

CADILLAC CTS 2003-2007 CADILLAC SRX 2004-2006

- 1** Disconnect the negative battery terminal to prevent an accidental short circuit.
- 2** Unclip and remove the center air vent assembly above the radio. (Figure A)
- 3** Open ashtray and remove (1) Phillips head screw from inside ashtray.
- 4** Unclip and remove the a/c control/ashtray assembly below the radio. (Figure B)
- 5** Remove (4) 10 MM screws securing the radio to the dash. (Figure C, D)

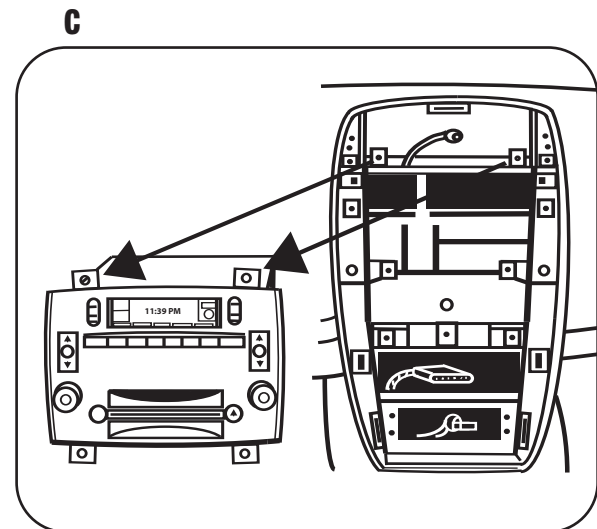
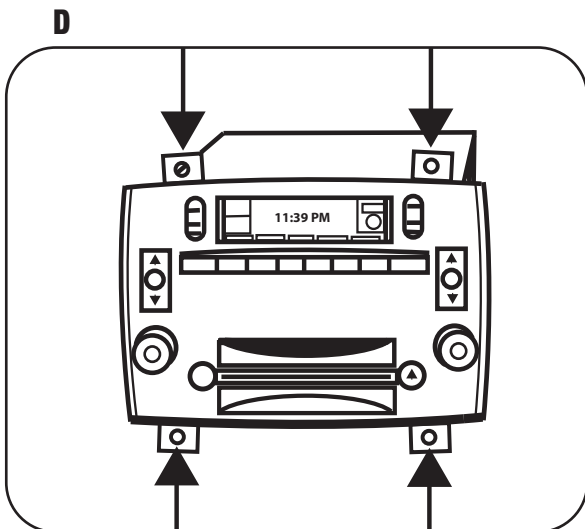
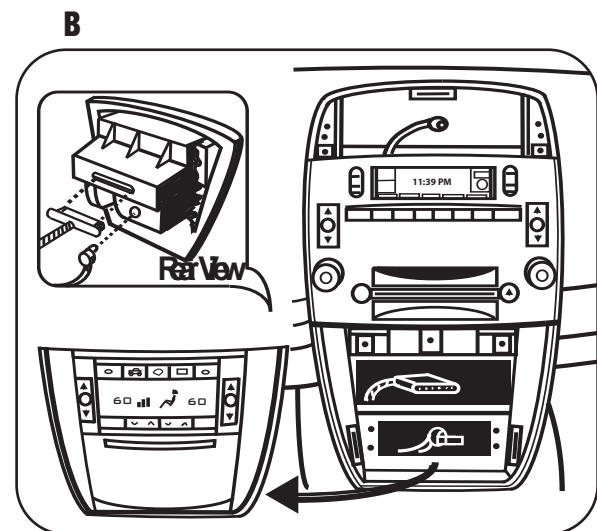
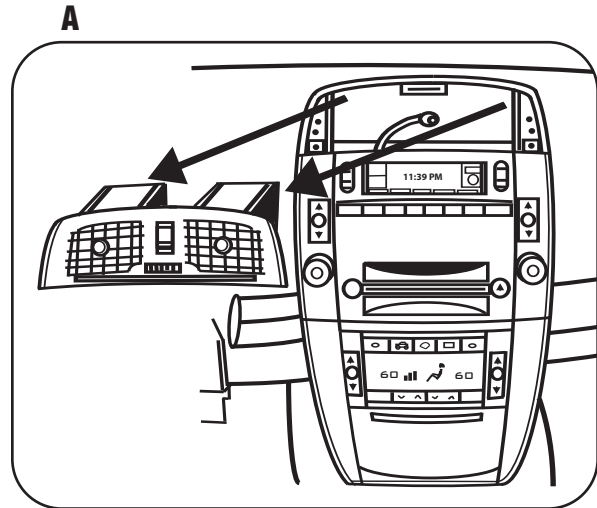

DIN RADIO PROVISION WITH POCKET

- 1** Slide the DIN cage into the Radio Housing and secure by bending the metal locking tabs down. (Figure A)
- 2** Slide the aftermarket head unit into the cage and secure. (Figure B)
- 3** Slide the supplied pocket into the unused opening.

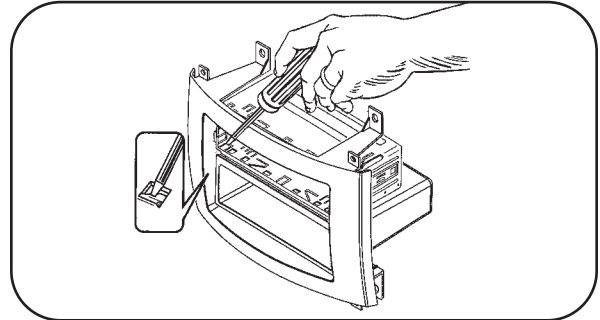
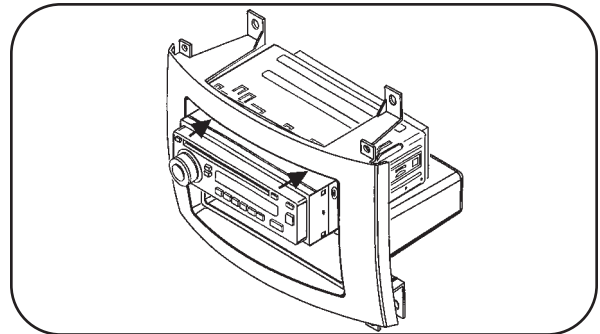
A

B

ISO MOUNT RADIO PROVISION WITH POCKET

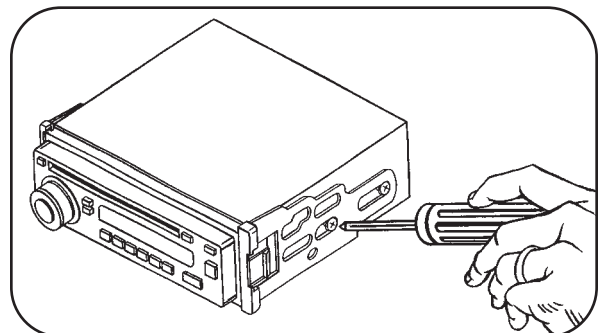
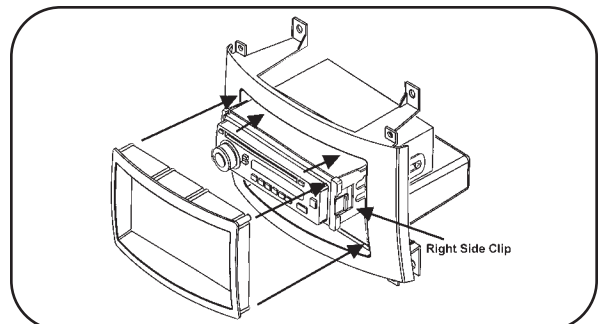
- 1** Mount the ISO Brackets to the head unit with the screws supplied with the unit. (Figure A)
- 2** Slide the head unit into the radio opening until the side clips engage. (Figure B)
- 3** Snap the Trim plate into the Radio Housing. (Figure B)
- 4** Slide the supplied pocket into the unused opening.

A

B

DOUBLE DIN RADIO PROVISION

- 1** Remove the center bar from the 99-2006 radio housing. (Figure A)
- 2** Attach the corresponding bracket to the DDIN head unit. (Figure B)
- 3** Insert the DDIN trim plate into the radio housing. (Figure C)
- 4** Position the bracket/radio assembly to the back of the radio housing and secure with the (8) Phillips screws provided. (Figure D)

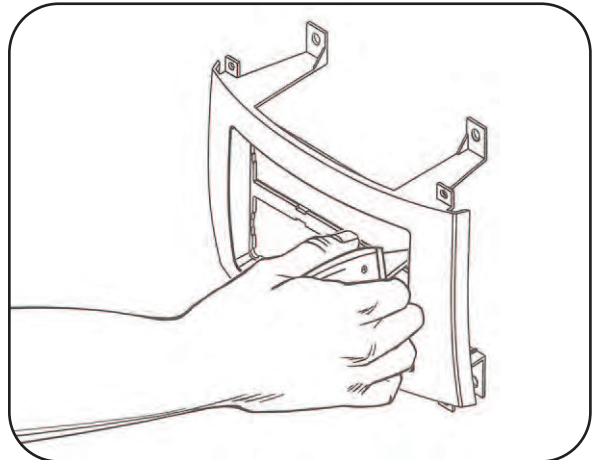
A



B

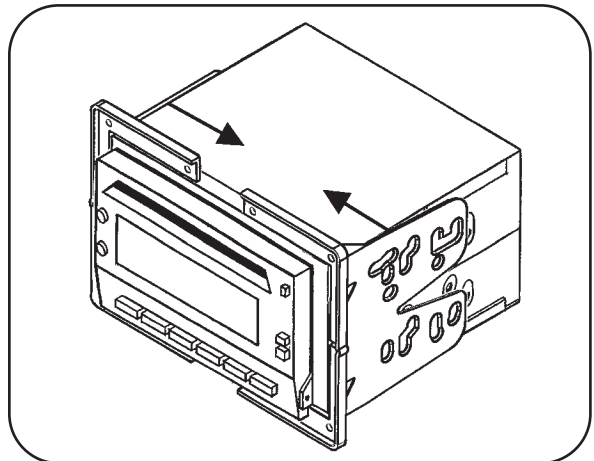

C

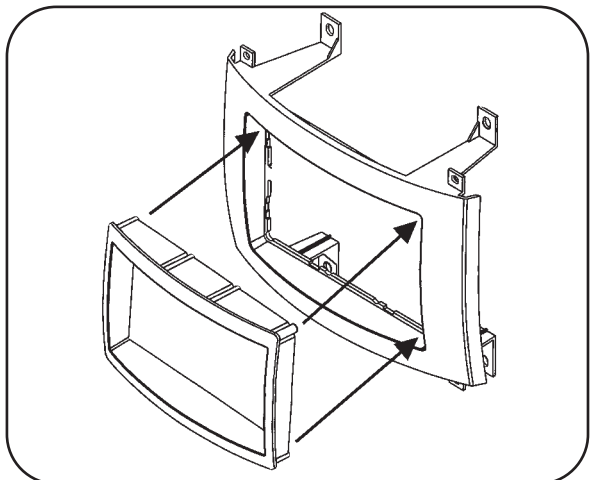

D

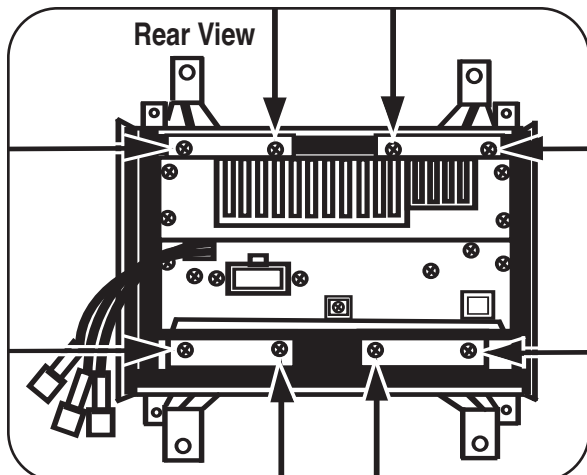

STACKED ISO MOUNT UNITS PROVISION

- 1 Mount the ISO Brackets to the head units with the screws supplied with the unit. (Figure A)
- 2 Slide the head units into the radio openings until the side clips engage. (Figure B)
- 3 Snap the Trim plate into the Radio Housing. (Figure B)

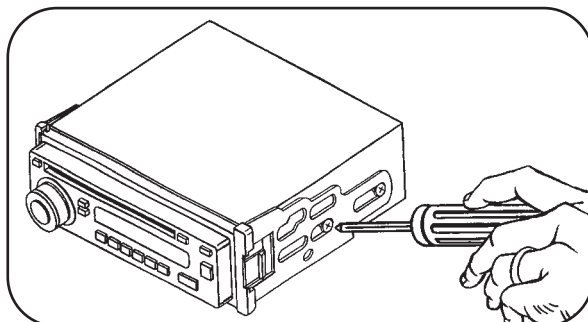
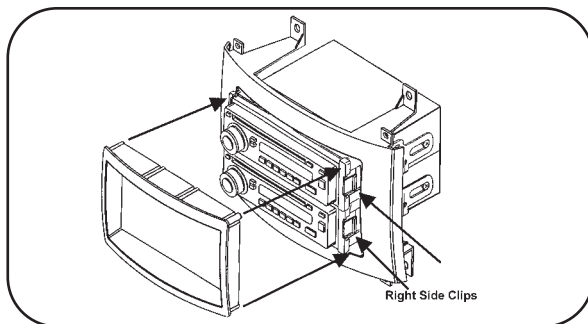
A

B

STACKED DIN HEAD UNITS PROVISION

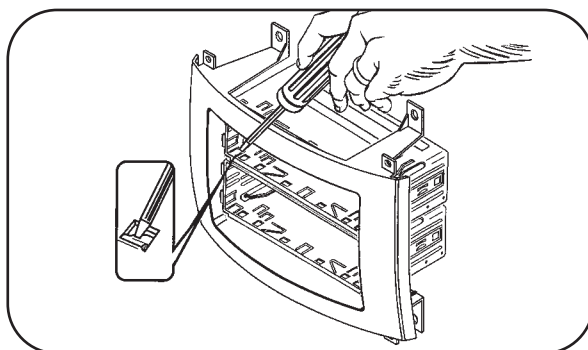
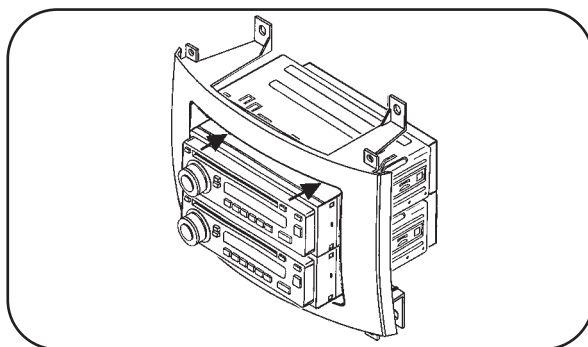
- 1 Slide the DIN cages into the Radio Housing and secure by bending the metal locking tabs outward. (Figure A)
- 2 Slide the aftermarket head units into the cages and secure. (Figure B)

A

B

FINAL ASSEMBLY

- 1** Locate the factory wiring harness in the dash and make the connection as shown. Metra recommends using the proper mating adapter and making the connections as shown. (Isolate and individually tape off the ends of any unused wires to prevent electrical short circuit.)
- 2** Re-connect the negative battery terminal and test the unit for proper operation.
- 3** Reassemble radio and dash assemblies in reverse order of disassembly.

FINAL WIRING CONNECTIONS

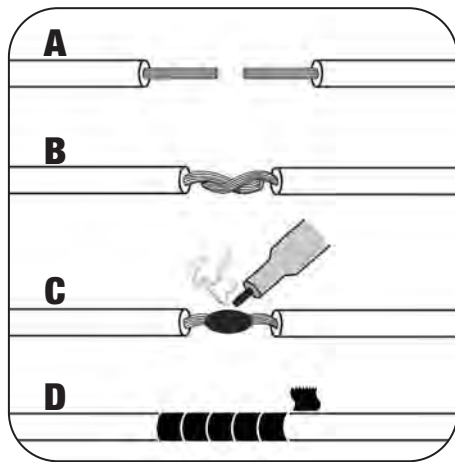
Make wiring connections using the EIA color code chart shown below and the instructions included with the head unit. Metra recommends making connections as shown below; Strip, Splice, Solder, Tape. Isolate and individually tape off ends of any unused wires to prevent electrical short circuit.



- A) Strip wire ends back 1/2"**
- B) Twist ends together**
- C) Solder**
- D) Tape**

METRA / EIA WIRING CODE

12V Ignition / Acc . . . Red	Right Front (+) Gray
12V Batt / Memory . . Yellow	Right Front (-) Gray / Black
Ground Black*	Left Front (+) White
Power Antenna Blue	Left Front (-) White / Black
Amp Turn-On Blue / White	Right Rear (+) Violet
Amp Ground Black / White	Right Rear (-) Violet / Black
Illumination Orange	Left Rear (+) Green
Dimmer Orange / White	Left Rear (-) Green / Black

***NOTE:** When Black a wire is not present, ground radio to vehicle chassis.

All colors may not be present on all leads due to manufacturer's specifications.

INST992006



1-800-221-0932



www.metraonline.com

Rev. 08-08-08 © COPYRIGHT 2004-2008 METRA ELECTRONICS CORPORATION INST99-2006