



INSTALLATION INSTRUCTIONS FOR PART 99-2007

APPLICATIONS

Cadillac Escalade

2007-2009

99-2007

KIT FEATURES

- ISO Mount Radio Provision With Pocket
- Double DIN Radio Provision
- Stacked ISO Units Provision



KIT COMPONENTS

- A) Radio Housing • B) Radio Housing Trim Plate • C) Radio Housing Brackets • D) Pocket
• E) 4) #8 3/8" Screws

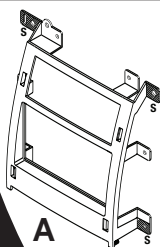

A

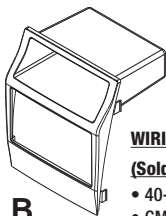

B

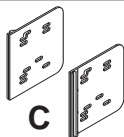

C

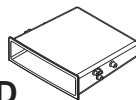

D



E

WIRING AND ANTENNA CONNECTIONS

(Sold Separately)

- 40-CR10 - 2002-up Chrysler/GM Antenna Adapter
- GMOS-LAN-05 - 2007-up GM LAN Digital Amp Interface

TOOLS REQUIRED:

- Small Flat Blade Screwdriver/ Panel Removal Tool
• Phillips Screwdriver • Socket Set



1-800-221-0932



www.metraonline.com

© COPYRIGHT 2004-2009 METRA ELECTRONICS CORPORATION

TABLE OF CONTENTS

Dash Disassembly

- Cadillac Escalade 2007-2009 1

Kit Preparation 2

Kit Assembly

- ISO Mount Radio Provision with Pocket 3

- Double DIN Radio Provision 4

- Stacked ISO Units Provision 5

Final Assembly 6

***Note:**

Refer also to the instructions included with the aftermarket radio.



KNOWLEDGE IS POWER

Enhance your installation and fabrication skills by enrolling in the most recognized and respected mobile electronics school in our industry. Log onto www.installerinstitute.com or call 800-354-6782 for more information and take steps toward a better tomorrow.

CADILLAC ESCALADE 2007-2009

- 1** Disconnect the negative battery terminal to prevent an accidental short circuit.
- 2** Unclip and remove cup holder and ashtray assembly. (Figure A)
- 3** Unclip and remove the trim panel above the glove box including the a/c vent. (Figure B)
- 4** Unclip and remove the entire panel surrounding the radio including the a/c vents. (Figure C)
- 5** Remove (6) 9/32" screws to extract radio from dash. (Figure D)

Continue to kit assembly.

A

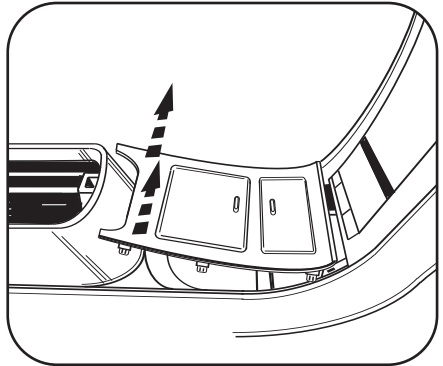

B

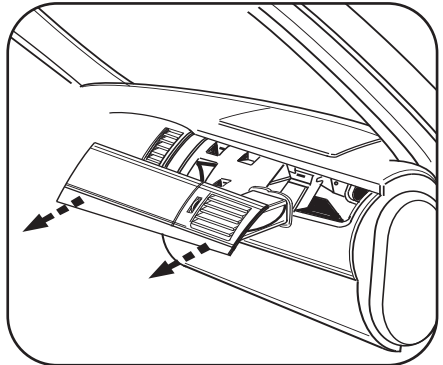

C

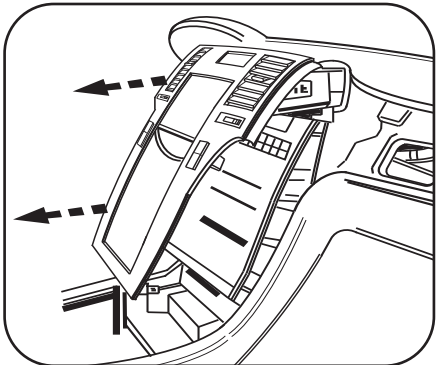

D

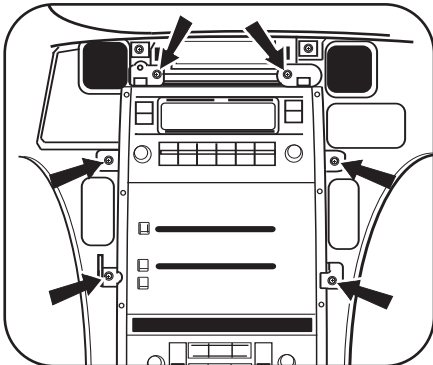

CADILLAC ESCALADE 2007-2009

- 1 Cut and remove the shaded areas marked with an "S" only from the radio housing. (Figure A) Right side and top of Radio housing. (Figure B) Left side and top of Radio housing.

NOTE: Do NOT remove the tab marked with both "S" and "E".

Continue to kit assembly.

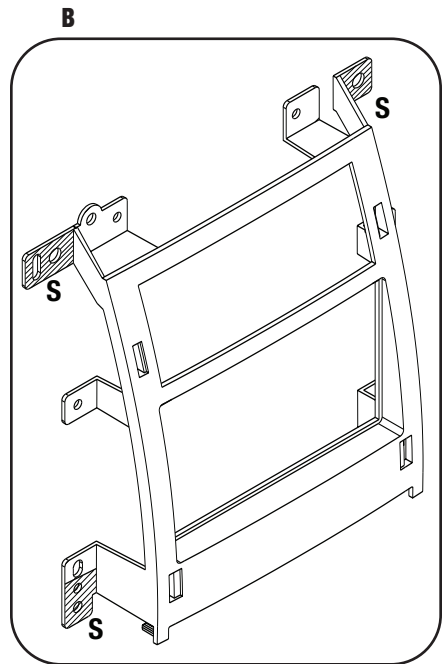
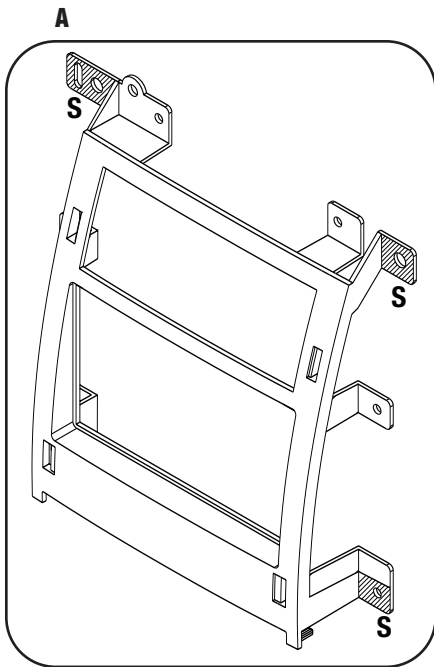

ISO MOUNT RADIO PROVISION WITH POCKET

**Note: Refer also to the instructions included with the aftermarket radio.*

- 1 Flip the radio housing brackets upside down then snap them to the inside edge of the radio housing. (Figure A)

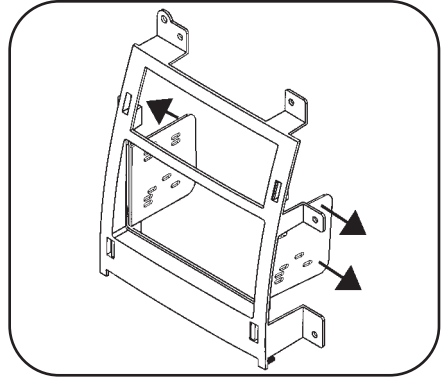
A

- 2 Slide the pocket into the top of the opening aligning the holes in the radio housing brackets with the bosses on the pocket and secure using the provided (4) #8 3/8" screws. (Figure B)

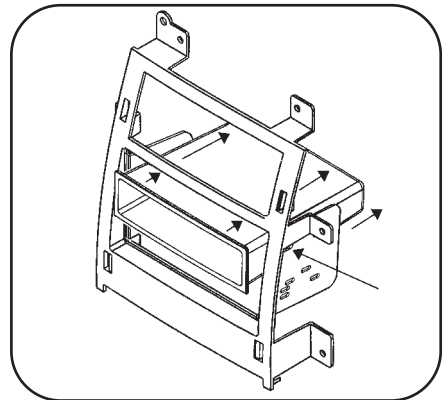
B

- 3 Slide the ISO radio into the opening below the pocket and secure the unit to the kit using the screws supplied with the radio. (Figure C)

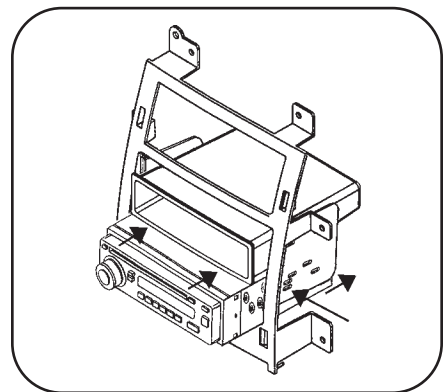
C

- 4 Snap the radio housing trim plate onto the front of the radio housing. (Figure D)

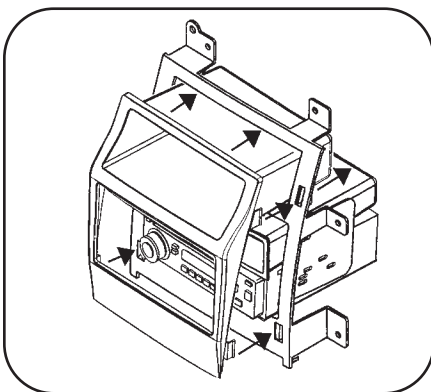
D

Continue to final assembly.

DOUBLE DIN RADIO PROVISION

**Note: Refer also to the instructions included with the aftermarket radio.*

- 1** Attach the radio housing brackets to the inside edge of the radio housing. (Figure A)
- 2** Slide the Double DIN radio into the radio housing bracket assembly and secure the unit using the screws supplied with the radio. (Figure B)
- 3** Snap the radio housing trim plate onto the front of the radio housing. (Figure C)

Continue to final assembly.

A

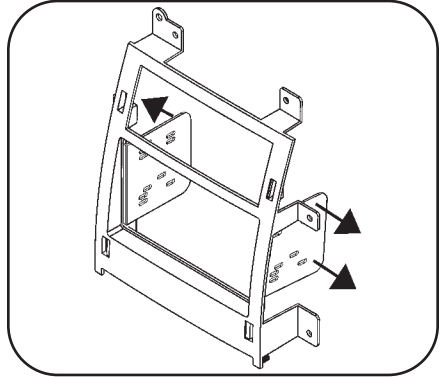

B

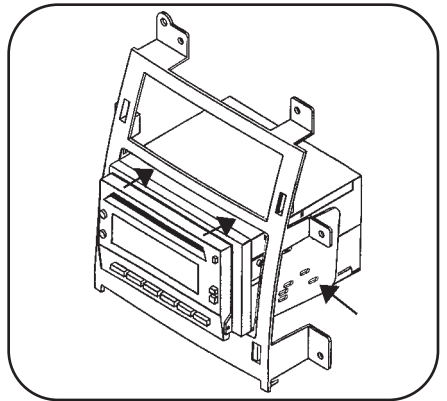

C

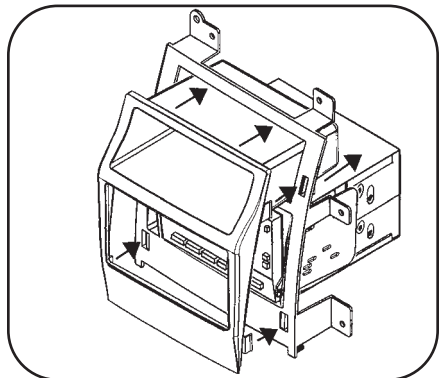

STACKED ISO UNITS PROVISION

**Note: Refer also to the instructions included with the aftermarket radio.*

- 1** Attach the radio housing brackets to the inside edge of the radio housing. (Figure A)
- 2** Slide the stacked ISO units into the radio housing bracket assembly and secure the unit using the screws supplied with the units. (Figure B)
- 3** Snap the radio housing trim plate onto the front of the radio housing. (Figure C)

Continue to final assembly.

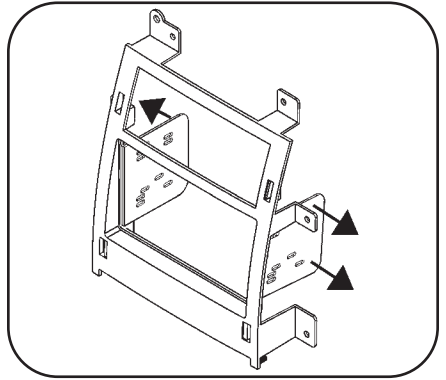
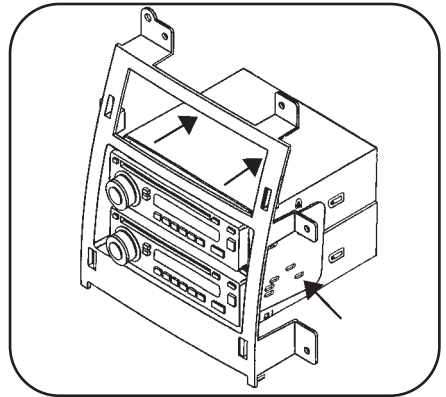
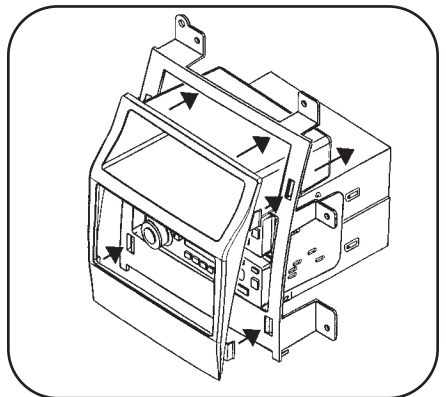
A

B

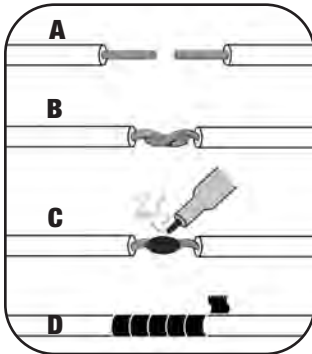
C

FINAL ASSEMBLY



(A) Strip wire ends back 1/2"

B) Twist ends together

C) Solder

D) Tape

- 1** Locate the factory wiring harness in the dash. Metra recommends using the proper mating adapter and making connections as shown. (Isolate and individually tape off the ends of any unused wires to prevent electrical short circuit.)
- 2** Re-connect the negative battery terminal and test the unit for proper operation.
- 3** Reassemble radio and dash assemblies in reverse order of disassembly.

FINAL WIRING CONNECTIONS

Make wiring connections using the EIA color code chart shown below and the instructions included with the head unit. Metra recommends making connections as shown below; Strip, Splice, Solder, Tape. Isolate and individually tape off ends of any unused wires to prevent electrical short circuit.

METRA / EIA WIRING CODE

12V Ignition / Acc. Red	Right Front (+) Gray
12V Batt / Memory. Yellow	Right Front (-) Gray/ Black
Ground. Black*	Left Front (+) White
Power Antenna Blue	Left Front (-) White / Black
Amp Turn-On Blue / White	Right Rear (+) Violet
Amp Ground. Black / White	Right Rear (-) Violet / Black
Illumination Orange	Left Rear (+) Green
Dimmer Orange / White	Left Rear (-) Green / Black

***NOTE:** When a Black wire is not present, ground radio to vehicle chassis.

All colors may not be present on all leads due to manufacturer's specifications.



1-800-221-0932



www.metraonline.com