



## INSTALLATION INSTRUCTIONS FOR PART 99-2010

### APPLICATIONS Cadillac STS 2005-2009

# 99-2010

#### KIT FEATURES

- ISO DIN Head Unit Provision With Pocket
- Double DIN Head Unit Provision
- Stacked ISO DIN Head Unit Provision
- *Painted matte black to match OEM finish*



#### KIT COMPONENTS

- A) Radio Housing
- B) Radio Housing Trim Plate
- C) Radio Housing Brackets
- D) Pocket
- E) (4) #8 3/8" Screws

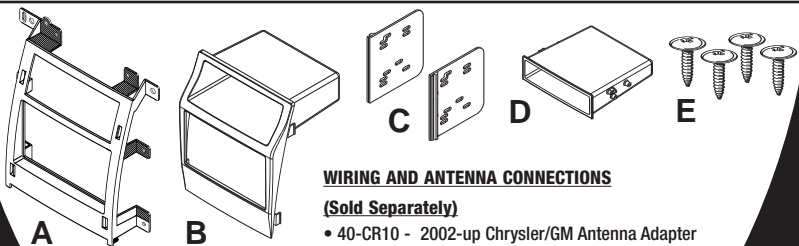

#### WIRING AND ANTENNA CONNECTIONS

(Sold Separately)

- 40-CR10 - 2002-up Chrysler/GM Antenna Adapter

#### TOOLS REQUIRED:

- Small Flat Blade Screwdriver/ Panel Removal Tool
- Phillips Screwdriver
- Socket Set



1-800-221-0932



www.metraonline.com

© COPYRIGHT 2004-2009 METRA ELECTRONICS CORPORATION

**TABLE OF CONTENTS**

**Dash Disassembly**

**- Cadillac STS 2005-2009 ..... 1**

**Kit Preparation ..... 2**

**Kit Assembly**

**- ISO DIN Head Unit Provisions with Pocket. .... 3**

**- Double DIN Head Unit Provision/Stacked ISO DIN Head Unit Provision. 4**

**\*Note:**

**Refer also to the instructions included with the aftermarket radio.**



**KNOWLEDGE IS POWER**

Enhance your installation and fabrication skills by enrolling in the most recognized and respected mobile electronics school in our industry. Log onto [www.installerinstitute.com](http://www.installerinstitute.com) or call 800-354-6782 for more information and take steps toward a better tomorrow.

## CADILLAC STS 2005-2009

- 1** Disconnect the negative battery terminal to prevent an accidental short circuit.
- 2** Unclip and remove the entire panel surrounding the radio including the a/c vents. (Figure A)
- 3** Remove (4) 10mm bolts to extract radio from dash. (Figure B)

*Continue to kit assembly.*

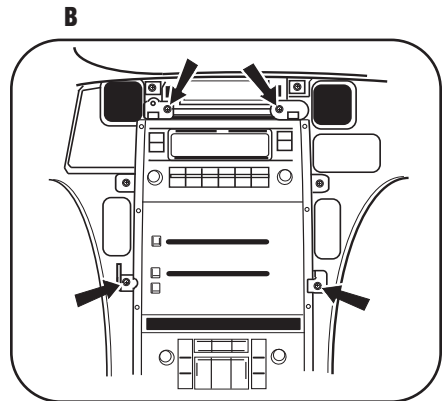
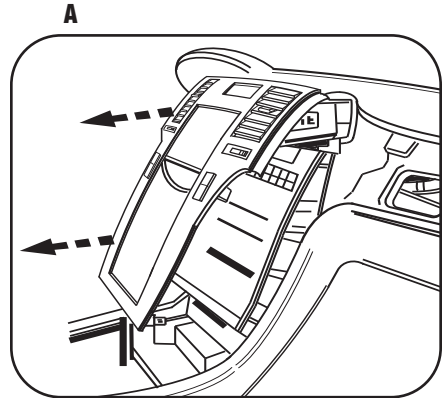

## CADILLAC STS 2005-2009

- 1 Cut and remove the shaded areas ***marked with an "E" only*** from the radio housing. (Figure A) Right side and top of Radio housing. (Figure B) Left side and top of Radio housing.

***NOTE: Do NOT remove the tab marked with both "S" and "E".***

*Continue to kit assembly.*

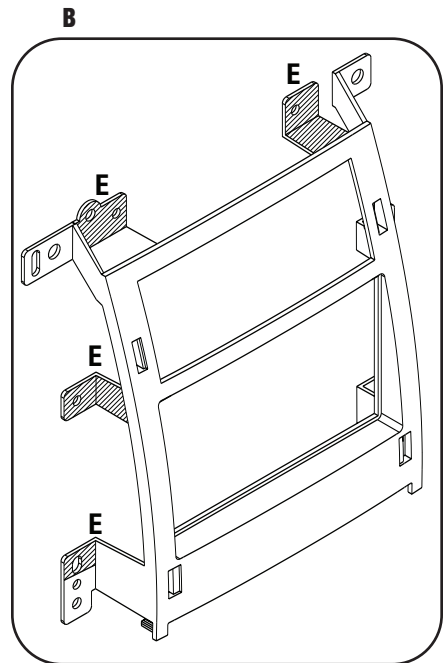
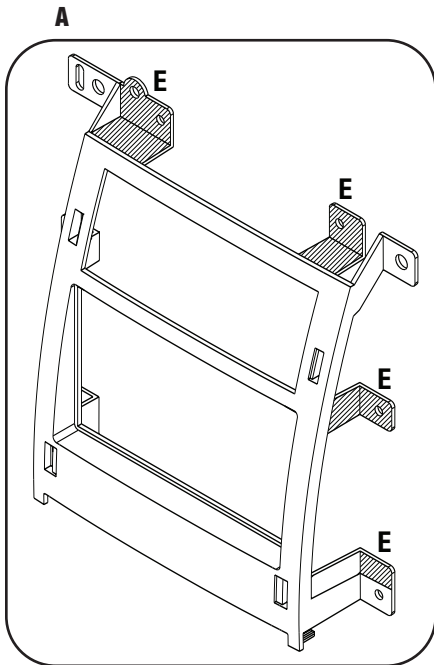

**ISO DIN HEAD UNIT PROVISIONS WITH POCKET**

*\*Note: Refer also to the instructions included with the aftermarket radio.*

- 1 Locate the factory wiring harness in the dash. Metra recommends using the proper mating adapter from Metra or AXCESS. Re-connect the negative battery terminal and test the unit for proper operation.
- 2 Flip the radio housing brackets upside down then snap them to the inside edge of the radio housing. (Figure A)
- 3 Slide the pocket into the top of the opening aligning the holes in the radio housing brackets with the bosses on the pocket and secure with the provided (4) #8 3/8" screws. (Figure B)
- 4 Slide the ISO DIN unit into the opening below the pocket and secure the unit to the kit using the screws supplied with the head unit. (Figure C)
- 5 Snap the radio housing trim plate onto the radio housing. (Figure D)
- 6 Reassemble dash in reverse order of disassembly.

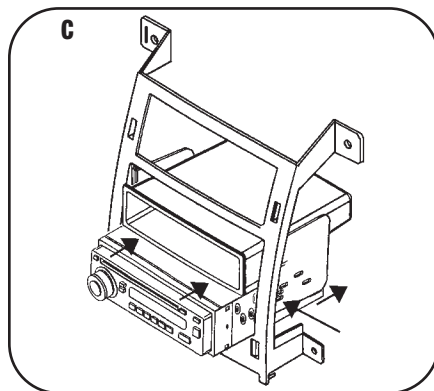
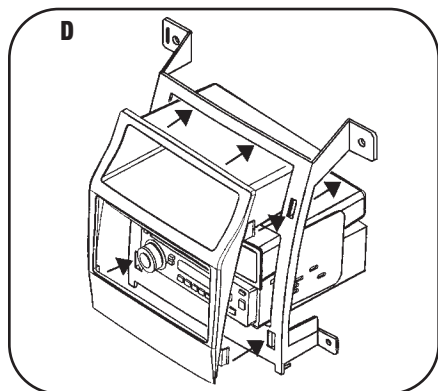
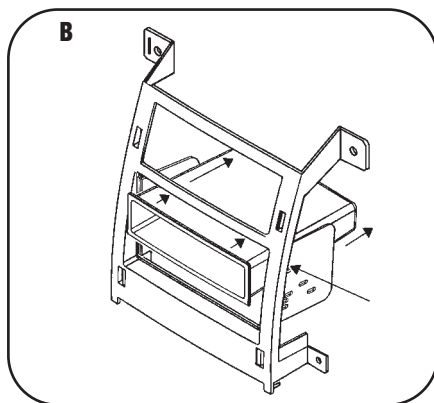
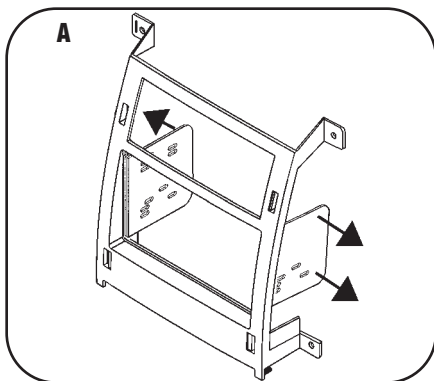

## DOUBLE DIN HEAD UNIT PROVISION/ STACKED ISO DIN HEAD UNIT PROVISION

*\*Note: Refer also to the instructions included with the aftermarket radio.*

- 1 Locate the factory wiring harness in the dash. Metra recommends using the proper mating adapter from Metra or AXCESS. Re-connect the negative battery terminal and test the unit for proper operation.
- 2 Snap the radio housing brackets to the inside edge of the Double DIN trim plate. (Figure A)
- 3 Slide the Double DIN head unit or stacked ISO head units into the bracket/radio housing assembly and secure the Double DIN head unit or stacked ISO head units to the assembly using the screws supplied with the radio. (Figure B)
- 4 Snap the radio housing trim plate onto the radio housing. (Figure C)
- 5 Reassemble dash in reverse order of disassembly.

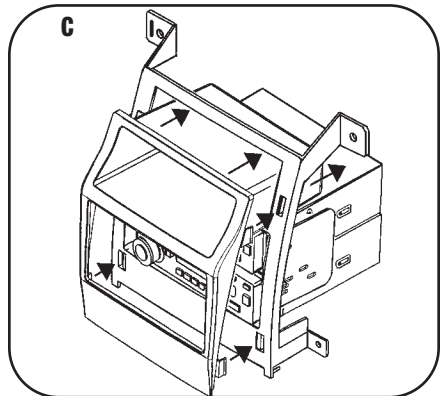
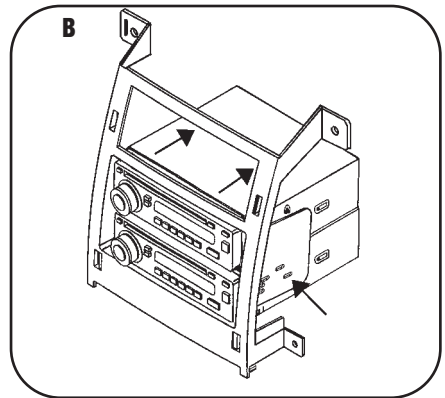
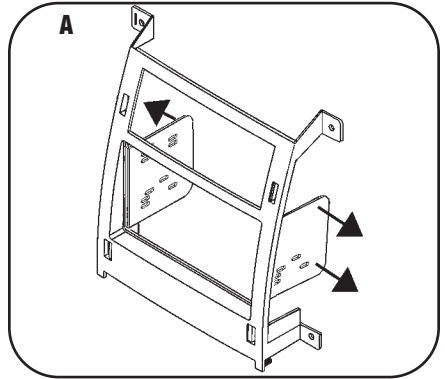



# 99-2010 INSTRUCTIONS



1-800-221-0932



[www.metraonline.com](http://www.metraonline.com)

REV. 08/06/09 © COPYRIGHT 2004-2009 METRA ELECTRONICS CORPORATION INST99-2010