

KIT FEATURES

- ▶ Shaft and DIN unit provisions

KIT COMPONENTS

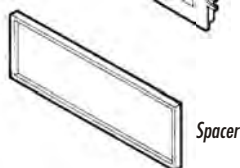
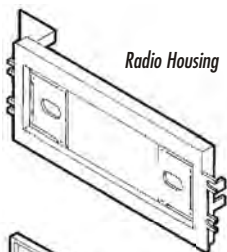

(1) Keps Nut



(1) Phillips
Pan-head Screw

(1) Carriage Bolt



TOOLS REQUIRED



Phillips screwdriver



Cutting tool



Socket wrench



99-3009

INSTALLATION INSTRUCTIONS

APPLICATIONS

CAR	PAGE
CHEVROLET	
Camaro 1993-96.....	1
PONTIAC	
Bonneville 1994-99.....	1
Firebird 1993.....	4
Firebird 1994-02.....	5
Grand Am 1996-98.....	2
Grand Am 1999-00.....	2
Grand Prix 1994-96.....	3
Grand Prix 1997-02.....	3
Sunfire 1995-99.....	4
Trans Am 1993.....	4
Trans Am 1994-02.....	5



1-800-221-0932



www.metraonline.com

© COPYRIGHT 2001 METRA ELECTRONICS CORPORATION

rev. 090103

CHEVROLET Camaro 1993-96

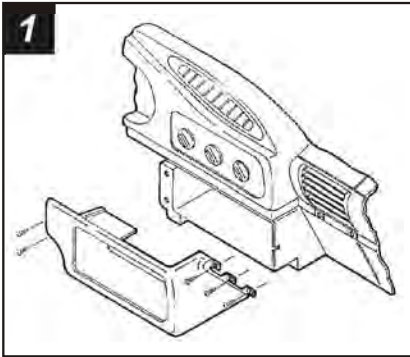

Disconnect the negative battery terminal to prevent an accidental short circuit. Remove (2) Phillips screws from the top of the driver's side knee bolster. Remove (2) 7mm screws from the bottom of the knee bolster. Open the glove box, remove (3) 7mm screws exposed on the right edge of the radio trim bezel and remove the bezel. Remove (2) 7mm screws securing the left side of the factory head unit and (1) 10mm nut securing the right. Slide the unit from the dash and disconnect the wiring.

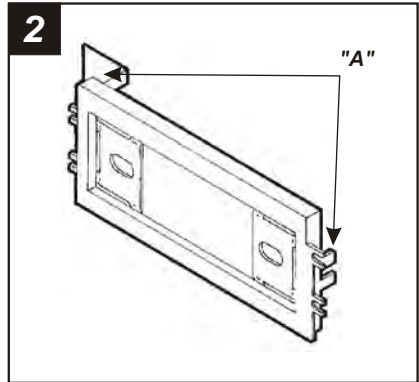

Cut and remove all mounting tabs on the **Radio Housing** EXCEPT tabs "A". The mounting tabs can be identified by the stamped letter on the back of each tab. Skip to the *Installation Instructions* for ALL VEHICLES on Page #5.

PONTIAC Bonneville 1994-99

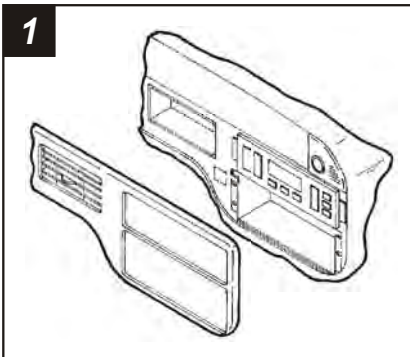

Disconnect the negative battery terminal to prevent an accidental short circuit. Unclip the right side of the dash trim bezel. Unclip the left side of the bezel and remove. Remove (3) 7mm hex-head screws securing the factory head unit and disconnect the wiring.

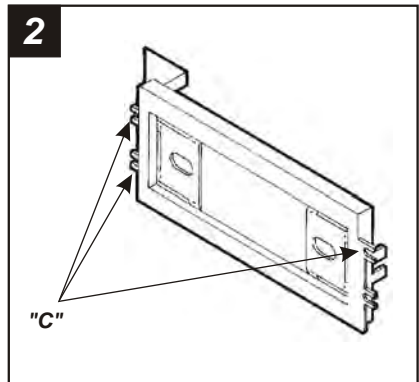

Cut and remove all mounting tabs on the **Radio Housing** EXCEPT tabs "C". The mounting tabs can be identified by the stamped letter on the back of each tab. Skip to the *Installation Instructions* for ALL VEHICLES on Page #5.

PONTIAC Grand Am 1996-98

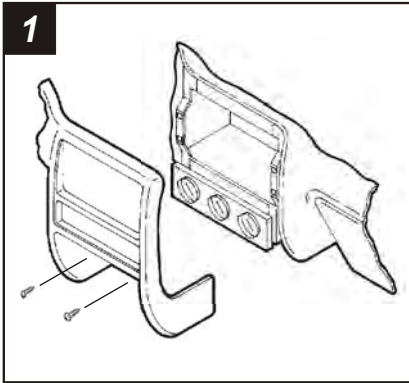

Disconnect the negative battery terminal to prevent an accidental short circuit. Remove (2) Phillips screws from the pocket. Remove (2) Phillips screws above the instrument cluster. Unclip the dash trim bezel and remove. Remove (3) 7mm hex-head screws securing the factory head unit and disconnect the wiring.

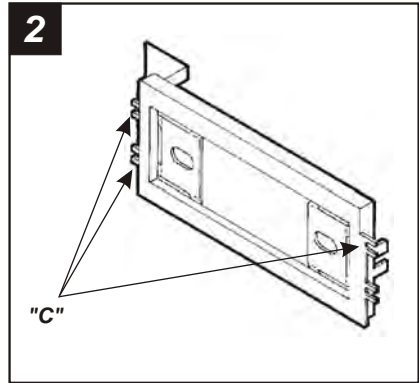

Cut and remove all mounting tabs on the **Radio Housing** EXCEPT tabs "C". The mounting tabs can be identified by the stamped letter on the back of each tab. Skip to the *Installation Instructions for ALL VEHICLES* on Page #5.

PONTIAC Grand Am 1999-00



Disconnect the negative battery terminal to prevent an accidental short circuit. Unclip the radio trim bezel. Remove (3) 9/32" screws securing the factory head unit and disconnect the wiring.

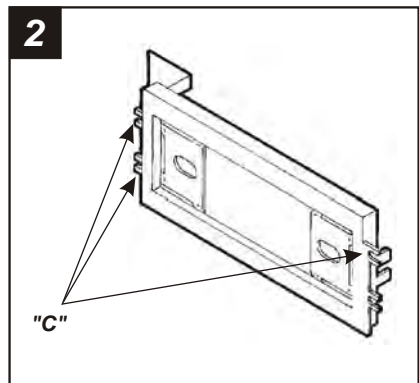

Cut and remove all mounting tabs on the **Radio Housing** EXCEPT tabs "C". The mounting tabs can be identified by the stamped letter on the back of each tab. Skip to the *Installation Instructions for ALL VEHICLES* on Page #5.

PONTIAC Grand Prix 1994-02

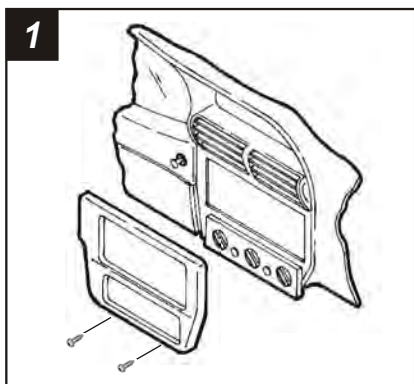

Disconnect the negative battery terminal to prevent an accidental short circuit. Using a small set of pliers, grasp the retaining clip on the back of the gear shifter handle and remove the clip. Remove the gear shifter handle. Unclip the center console and remove. Remove (2) 7mm hex-head screws exposed under the climate controls. Unclip the radio trim bezel and remove. Remove (2) 7mm hex-head screws securing the factory head unit and disconnect the wiring.

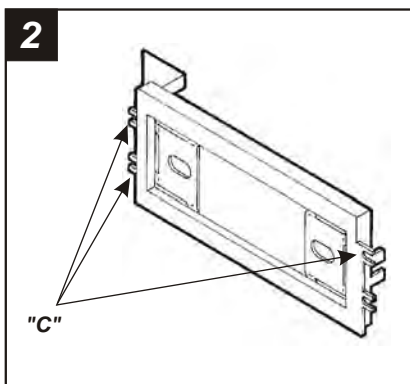

Cut and remove all mounting tabs on the **Radio Housing** EXCEPT tabs "C". The mounting tabs can be identified by the stamped letter on the back of each tab. Skip to the *Installation Instructions* for ALL VEHICLES on Page #5.

PONTIAC Grand Prix 1997-99

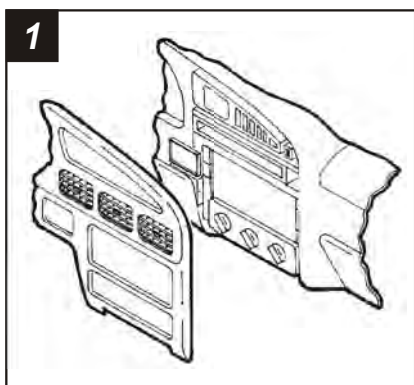

Disconnect the negative battery terminal to prevent an accidental short circuit. Unclip the entire dash trim bezel. Remove the screws securing the factory head unit and disconnect the wiring.

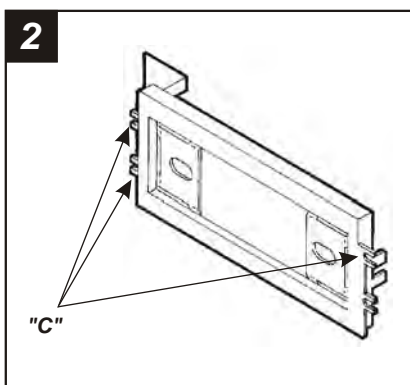

Cut and remove all mounting tabs on the **Radio Housing** EXCEPT tabs "C". The mounting tabs can be identified by the stamped letter on the back of each tab. Skip to the *Installation Instructions* for ALL VEHICLES on Page #5.

PONTIAC Sunfire 1995-99

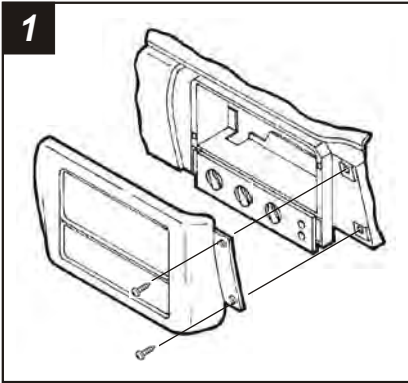

1
Disconnect the negative battery terminal to prevent an accidental short circuit. Open the glove box and remove (2) Phillips screws exposed on the right edge of the radio trim bezel. Unclip the bezel and remove. Remove (2) 7mm hex-head screws securing the factory head unit and disconnect the wiring.

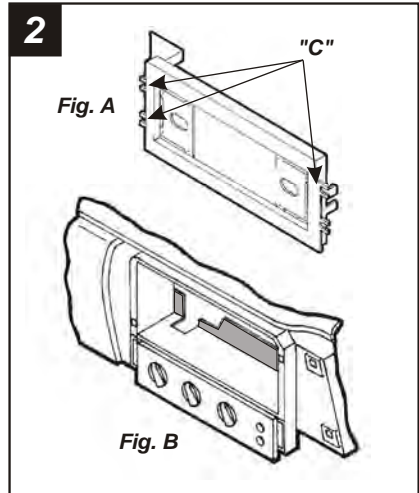

2
Cut and remove all mounting tabs on the **Radio Housing** EXCEPT tabs "C". (see Fig. A). Using a dremel tool, cut and remove the shaded portions of the sub-dash plastic. This will provide the necessary depth for installation. (see Fig. B). Skip to the *Installation Instructions for ALL VEHICLES* on Page #5.

PONTIAC Trans Am / Firebird 1993

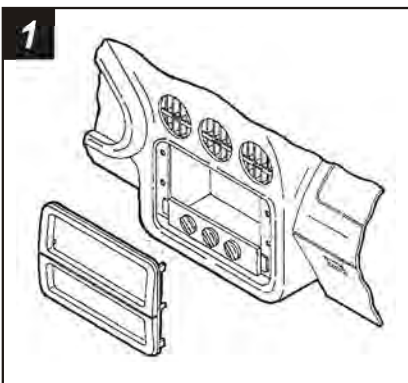

1
Disconnect the negative battery terminal to prevent an accidental short circuit. Unclip the radio trim bezel. Remove (4) 7mm hex-head screws securing the factory head unit and disconnect the wiring.

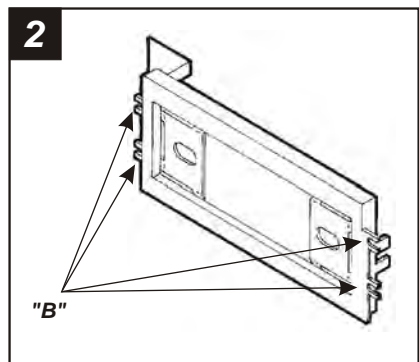

2
Cut and remove all mounting tabs on the **Radio Housing** EXCEPT tabs "B". The mounting tabs can be identified by the stamped letter on the back of each tab. Skip to the *Installation Instructions for ALL VEHICLES* on Page #5.

PONTIAC Trans Am / Firebird 1994-02

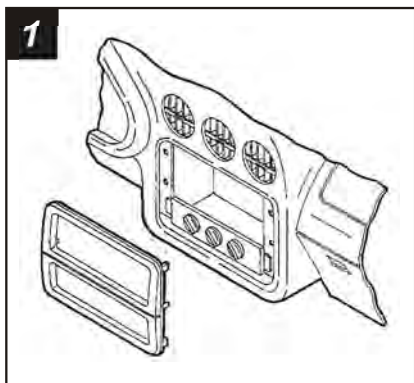

1
Disconnect the negative battery terminal to prevent an accidental short circuit. Unclip the radio trim bezel. Remove (4) 7mm hex-head screws securing the factory head unit and disconnect the wiring.

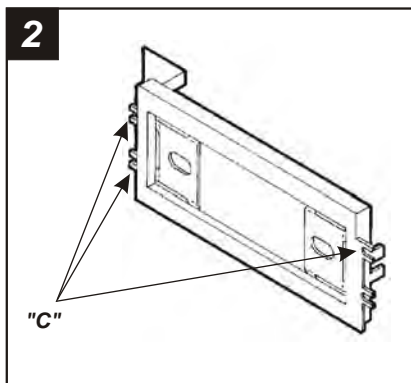

2
Cut and remove all mounting tabs on the **Radio Housing** EXCEPT tabs "C". The mounting tabs can be identified by the stamped letter on the back of each tab. Skip to the *Installation Instructions* for ALL VEHICLES on Page #5.

ALL VEHICLES

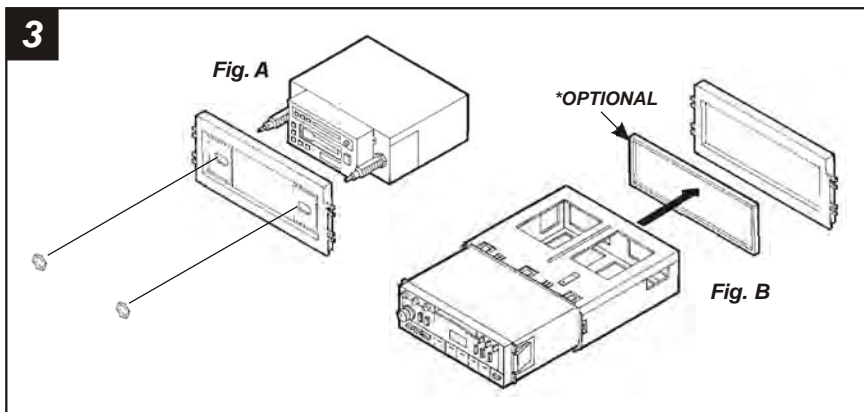

3
2-SHAFT HEAD UNITS: Slide the aftermarket head unit into the kit and secure with shaft nuts. (see Fig. A)

DIN HEAD UNITS: Insert the **Spacer*** into the **Radio Housing**. Slide the DIN cage into the kit and secure by bending the metal locking tabs down. Slide the aftermarket head unit into the cage until secure. (see Fig. B)

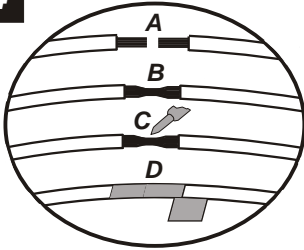
4

- A) Strip wire ends back ½"**
B) Twist ends together
C) Solder
D) Tape

Locate the factory wiring harness in the dash. Metra recommends using the proper mating adaptor and making connections as shown. (Isolate and individually tape off the ends of any unused wires to prevent electrical short circuit).

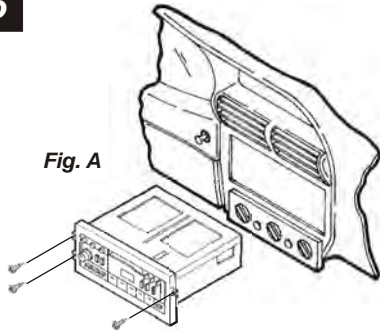
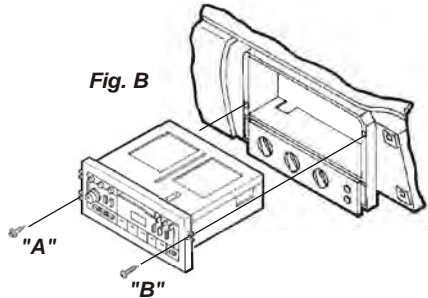
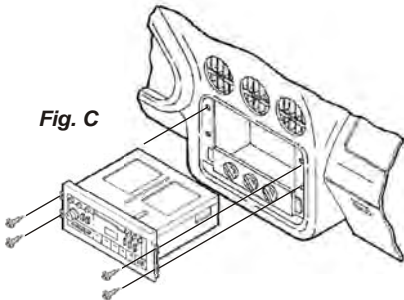
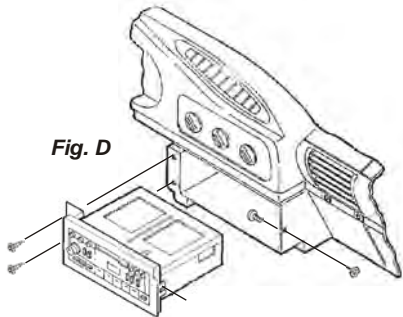
5**Fig. A****Fig. B****Fig. C****Fig. D**

FIREBIRD 1994-99, TRANS AM 1994-99, BONNEVILLE, GRAND AM, GRAND PRIX: Re-connect the battery terminal and test the unit for proper operation. Mount the head unit/kit assembly to the sub-dash with (3) 7mm hex-head screws previously removed in step #1. (Run the upper-left screw through the dash plastic for the Grand Prix). (see Fig. A)

SUNFIRE: Re-connect the battery terminal and test the unit for proper operation. Mount the head unit/kit assembly to the sub-dash with (1) 7mm hex-head screw previously removed in step #1 ("A") and (1) **Phillips Pan-head Screw** supplied ("B"). (see Fig. B)

FIREBIRD 1993, TRANS AM 1993: Re-connect the battery terminal and test the unit for proper operation. Mount the head unit/kit assembly to the sub-dash with (4) 7mm hex-head screws previously removed in step #1. (see Fig. C)

CAMARO 1993-96: Re-connect the battery terminal and test the unit for proper operation. Mount the head unit/kit assembly to the sub-dash with (2) 7mm hex-head screws previously removed in step #1 and (1) **Carriage Bolt** and (1) **Keps Nut** supplied. (see Fig. D)