

KIT FEATURES

- ▶ Shaft and DIN unit provisions
- ▶ Rear support provisions



99-3042

INSTALLATION INSTRUCTIONS

KIT COMPONENTS

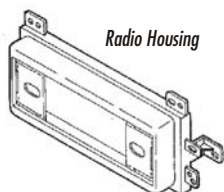

Radio Housing

Rear
Support
Bullet



APPLICATIONS

| CAR | PAGE |
|---------------------------|-------------|
| CHEVROLET | |
| Blazer 1986-93..... | 2 |
| Camaro 1982-92..... | 1 |
| S-10 Pickup 1986-93..... | 2 |
| GMC | |
| Jimmy 1986-93..... | 2 |
| S-15 Pickup 1986-93..... | 2 |
| PONTIAC | |
| Firebird 1982-92..... | 1 |
| SATURN | |
| (All models) 1991-94..... | 2 |

TOOLS REQUIRED



Torx-head screwdriver



Phillips screwdriver



Cutting tool



Socket wrench



CHEVROLET Camaro 1982-92 PONTIAC Firebird 1982-92

1

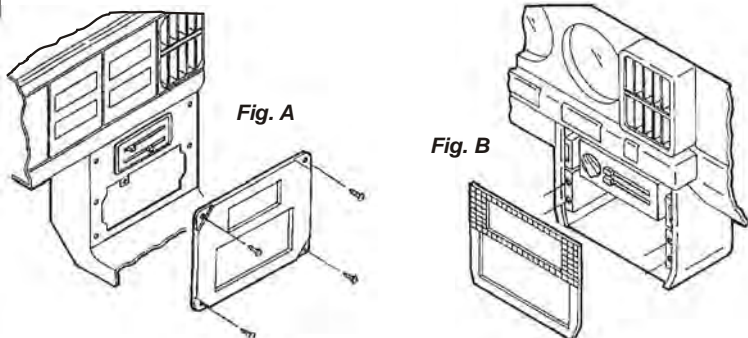

CAMARO 1982-92, FIREBIRD 1982-84: Disconnect the negative battery terminal to prevent an accidental short circuit. Remove (4) torx-head screws from the radio trim bezel. Remove (4) hex-head screws securing the factory radio dummy plate and remove the plate. (see Fig. A)

FIREBIRD 1985-92: Disconnect the negative battery terminal to prevent an accidental short circuit. Unclip the radio trim bezel and remove the bezel. Remove (4) hex-head screws securing the factory radio dummy plate and remove the plate. (see Fig. B)

2

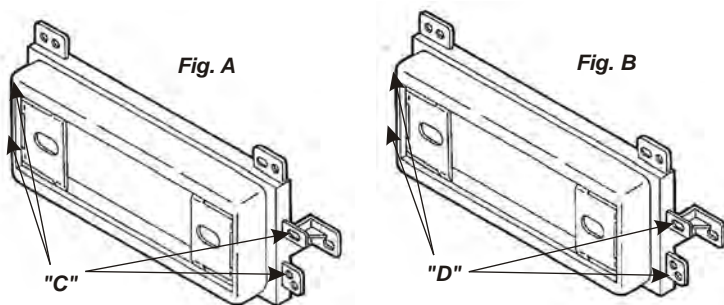

CAMARO 1985-92, FIREBIRD 1985-92: Cut and remove all mounting tabs on the **Radio Housing** EXCEPT tabs "C". The mounting tabs can be identified by the stamped letter on the back of each tab. (see Fig. A). Skip to the *Installation Instructions for ALL VEHICLES* on Page #3.

CAMARO 1982-84, FIREBIRD 1982-84: Cut and remove all mounting tabs on the **Radio Housing** EXCEPT tabs "D". The mounting tabs can be identified by the stamped letter on the back of each tab. (see Fig. B). Skip to the *Installation Instructions for ALL VEHICLES* on Page #3.

CHEVROLET S-10 Pickup / Blazer 1986-93 GMC S-15 Pickup / Jimmy 1986-93

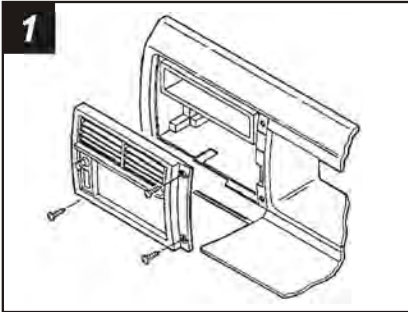

Disconnect the negative battery terminal to prevent an accidental short circuit. Remove the ashtray and (1) Phillips screw exposed in the ashtray cavity. Open the glove box and remove (2) Phillips screws exposed on the right edge of the radio trim bezel. Remove the radio trim bezel and disconnect the wiring.

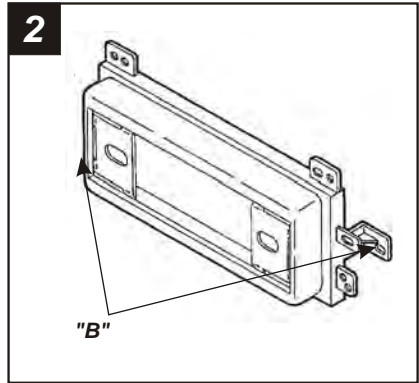

Cut and remove all mounting tabs on the **Radio Housing** EXCEPT tabs "B". The mounting tabs can be identified by the stamped letter on the back of each tab. Skip to the *Installation Instructions for ALL VEHICLES* on Page #3.

SATURN (all models) 1991-94

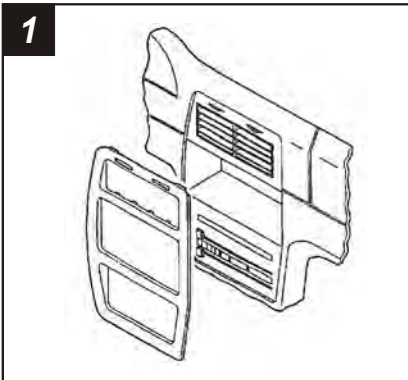

Disconnect the negative battery terminal to prevent an accidental short circuit. Unclip the dash trim bezel. Remove (4) hex-head screws securing the factory head unit and disconnect the wiring.

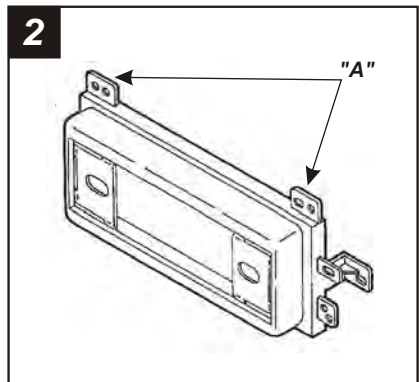

Cut and remove all mounting tabs on the **Radio Housing** EXCEPT tabs "A". The mounting tabs can be identified by the stamped letter on the back of each tab. Skip to the *Installation Instructions for ALL VEHICLES* on Page #3.

ALL VEHICLES

3

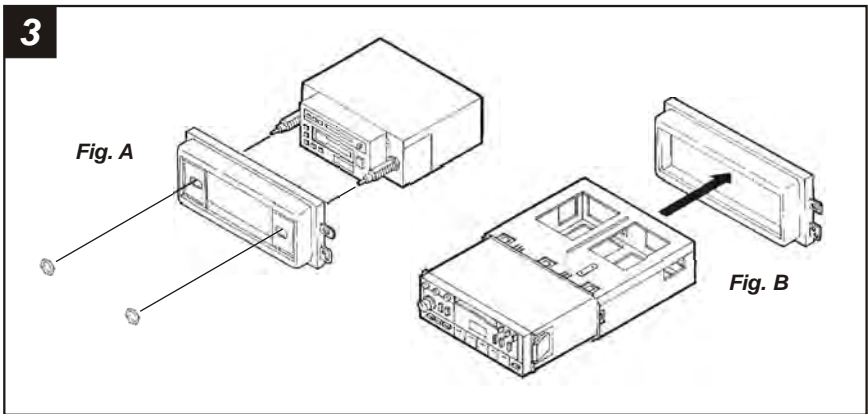

2-SHAFT HEAD UNITS: Slide the aftermarket head unit into the kit and secure with shaft nuts. (see Fig. A)

DIN HEAD UNITS: Cut and remove the shaft supports from the **Radio Housing**. Slide the DIN cage into the kit and secure by bending the metal locking tabs down. Slide the aftermarket head unit into the cage until secure. (see Fig. B)

4

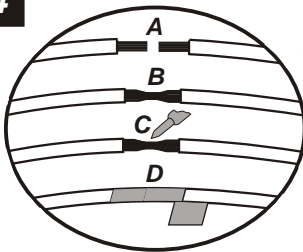

- A) Strip wire ends back $\frac{1}{2}$ "
- B) Twist ends together
- C) Solder
- D) Tape

Locate the factory wiring harness in the dash. Metra recommends using the proper mating adaptor and making connections as shown. (Isolate and individually tape off the ends of any unused wires to prevent electrical short circuit).

5

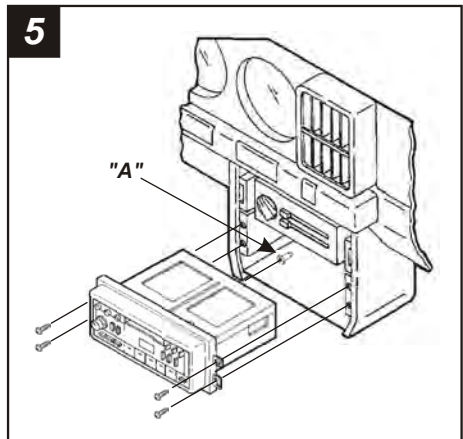

Re-connect the battery terminal and test the unit for proper operation. Screw the **Rear Support Bullet** onto the bolt on the back of the aftermarket head unit ("A"). Mount the radio/kit assembly to the sub-dash with those screws previously removed in step #1.