

## KIT FEATURES

- ▶ Shaft and DIN unit provisions
- ▶ Rear support provisions

## KIT COMPONENTS

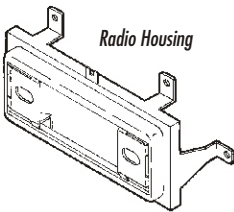

# 99-3200 INSTALLATION INSTRUCTIONS

## APPLICATIONS

| CAR                     | PAGE |
|-------------------------|------|
| <b>BUICK</b>            |      |
| Roadmaster 1991-94..... | 1    |
| <b>CHEVROLET</b>        |      |
| Beretta 1991-96.....    | 1    |
| Caprice 1991-93.....    | 1    |
| Cavalier 1991-94.....   | 2    |
| Corsica 1991-96.....    | 1    |



## TOOLS REQUIRED



Phillips screwdriver



Cutting tool



Socket wrench

☎ 1-800-221-0932    💻 [www.metraonline.com](http://www.metraonline.com)

© COPYRIGHT 2001 METRA ELECTRONICS CORPORATION

rev. 290601

## CHEVROLET Beretta / Corsica 1991-96

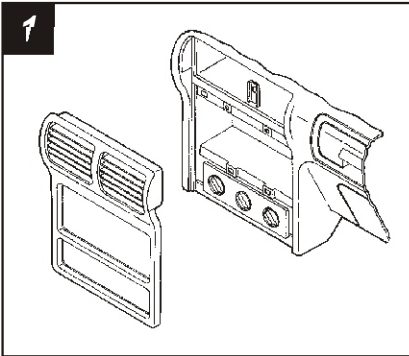

Disconnect the negative battery terminal to prevent an accidental short circuit. Using a panel removal tool, pry out on the dash trim bezel and remove. Remove (2) screws securing the factory head unit and disconnect the wiring.

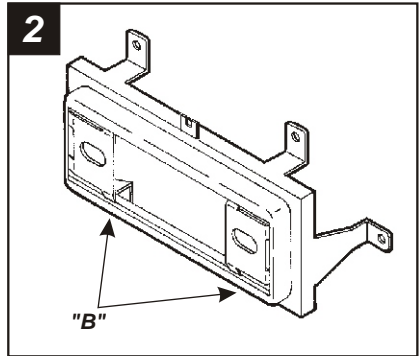

Cut and remove all mounting tabs on the **Radio Housing** EXCEPT tabs "B". The mounting tabs can be identified by the stamped letter on the back of each tab. Skip to the *Installation Instructions for ALL VEHICLES* on Page #2.

## BUICK Roadmaster 1991-94 CHEVROLET Caprice 1991-93

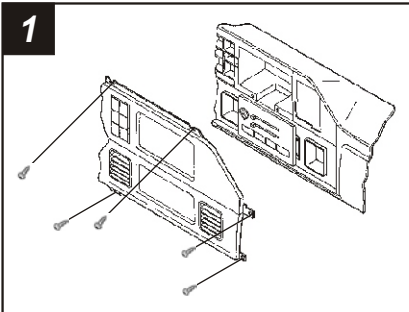

Disconnect the negative battery terminal to prevent an accidental short circuit. Remove (2) screws from the driver's side service panel and unclip the panel. Pry off the trim piece located above the glove box and remove (1) screw. Remove (3) screws from the top edge of the dash trim bezel. Remove (1) screw from the lower-left corner of the glove box and (1) screw from the parking brake release. Remove the dash trim bezel. Remove (3) 9/32" hex-head screws securing the factory head unit and disconnect the wiring.

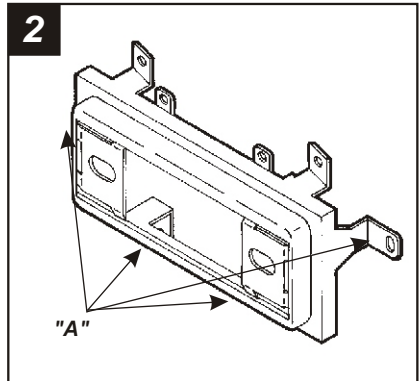

Cut and remove all mounting tabs on the **Radio Housing** EXCEPT tabs "A". The mounting tabs can be identified by the stamped letter on the back of each tab. Skip to the *Installation Instructions for ALL VEHICLES* on Page #2.

# CHEVROLET Cavalier 1991-94

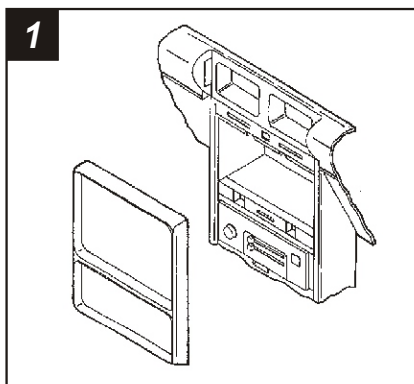

1  
Disconnect the negative battery terminal to prevent an accidental short circuit. Using a panel removal tool, pry out on the dash trim bezel and remove. Remove (2) screws securing the factory head unit and disconnect the wiring.

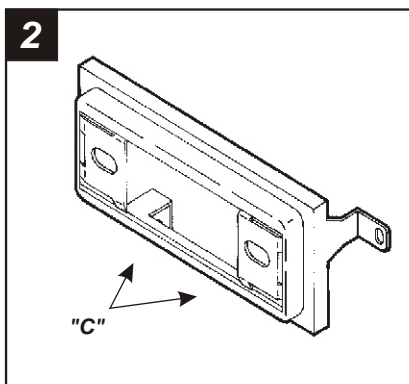

2  
Cut and remove all mounting tabs on the **Radio Housing** EXCEPT tabs "C". The mounting tabs can be identified by the stamped letter on the back of each tab. Skip to the *Installation Instructions* for ALL VEHICLES on Page #2.

## ALL VEHICLES

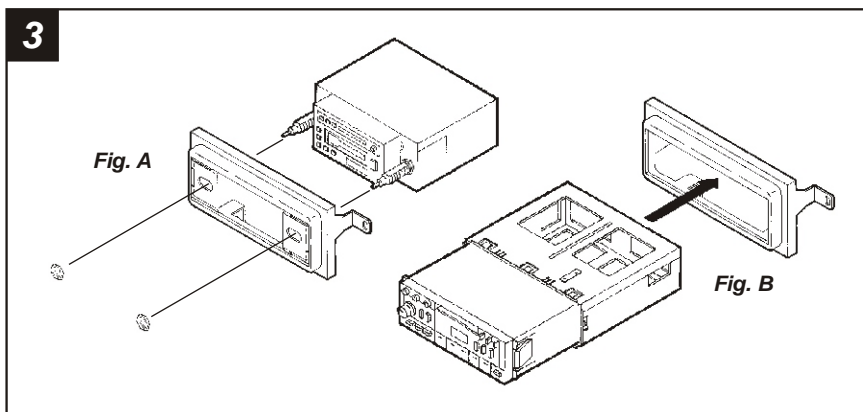

3  
**2-SHAFT HEAD UNITS:** Slide the aftermarket head unit into the kit and secure with shaft nuts. (see Fig. A)

**DIN HEAD UNITS:** Cut and remove the shaft supports from the **Radio Housing**. Slide the DIN cage into the kit and secure by bending the metal locking tabs down. Slide the aftermarket head unit into the cage until secure. (see Fig. B)

4

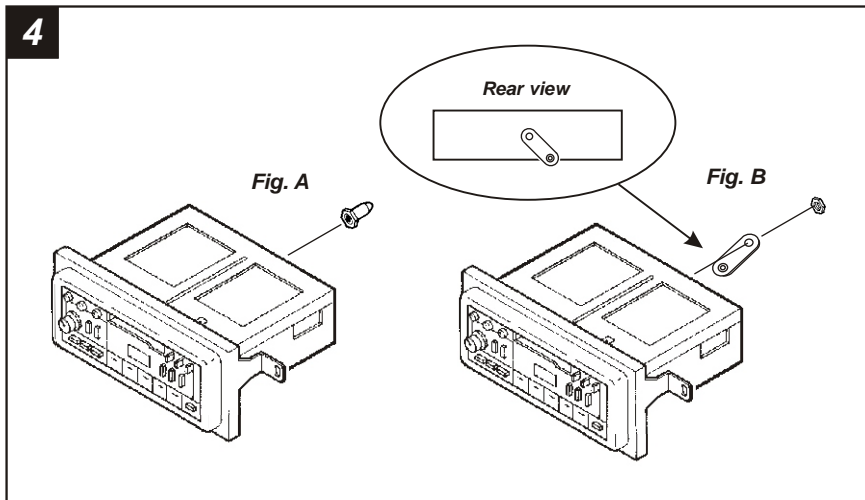

**BERETTA, CORSICA, CAVALIER:** Mount the **Rear Support Bullet** to the back of the aftermarket head unit using the hardware included with the unit. (see Fig. A)

**CAPRICE, ROADMASTER:** Mount the **Offset Rear Support** to the back of the aftermarket head unit using the hardware included with the unit. (see Fig. B)

5

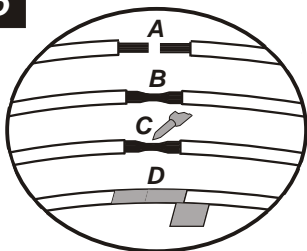

- A) Strip wire ends back ½"
- B) Twist ends together
- C) Solder
- D) Tape

Locate the factory wiring harness in the dash. Metra recommends using the proper mating adaptor and making connections as shown. (Isolate and individually tape off the ends of any unused wires to prevent electrical short circuit).

6

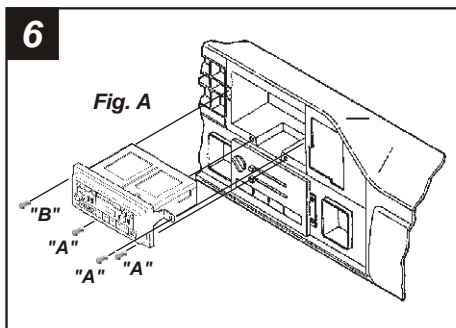

**CAPRICE, ROADMASTER:** Re-connect the battery terminal and test the unit for proper operation. Mount the head unit/kit assembly to the sub-dash with (3) 9/32" hex-head screws previously removed ("A") and (1) 9/32" hex-head screw securing the edge of the instrument cluster ("B"). (see Fig. A)

**BERETTA, CAVALIER, CORSICA:** Re-connect the battery terminal and test the unit for proper operation. Mount the head unit/kit assembly to the sub-dash with those screws previously removed in step #1.