



INSTALLATION INSTRUCTIONS FOR PART 99-3303

APPLICATIONS

Chevrolet Cobalt 2005-2006
Chevrolet Malibu 2004-2007
Chevrolet Malibu Classic 2008
Pontiac G6 2005-2009

99-3303

KIT FEATURES

- DIN Head Unit Provision with Driver Information Center (DIC)
- ISO DIN Head Unit Provision with Driver Information Center (DIC)



KIT COMPONENTS

A) Radio Housing • B) ISO Brackets • C) ISO Trim Plate • D) DIN Spacer • E) Wire Harness

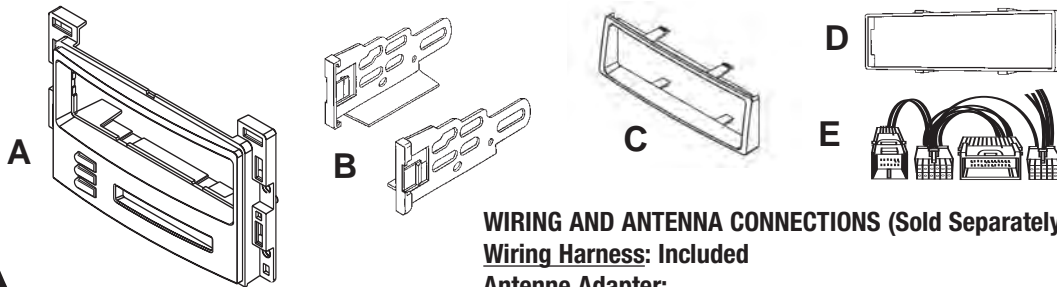

WIRING AND ANTENNA CONNECTIONS (Sold Separately)

Wiring Harness: Included

Antenne Adapter:

- 40-GM10 - GM antenna adapter 1988-up

TOOLS REQUIRED:

Phillips Screwdriver • Socket Wrench • Flat Blade Screwdriver • Cutting Tool (Cobalt Only)

Wire Cutters • Wire Strippers

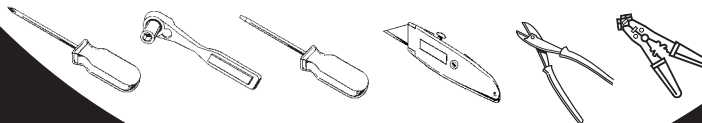

1-800-221-0932



www.metraonline.com

© COPYRIGHT 2004-2009 METRA ELECTRONICS CORPORATION



99-3303

TABLE OF CONTENTS

- *Dash Disassembly*
 - *Chevrolet Malibu 2004-2007* 1,2
 - *Chevrolet Malibu Classic 2008*..... 1,2
 - *Pontiac G6 2005-2009* 3
 - *Chevrolet Cobalt 2005-2006* 4

- *Kit Assembly*
 - *DIN Head Unit Provision with Pocket* 5
 - *ISO Head Unit Provision with Pocket* 6

- *Final Assembly* 7
- *Operation of the 99-3303* 8



KNOWLEDGE IS POWER

Enhance your installation and fabrication skills by enrolling in the most recognized and respected mobile electronics school in our industry. Log onto www.installerinstitute.com or call 800-354-6782 for more information and take steps toward a better tomorrow.

CHEVROLET MALIBU 2004-2007

CHEVROLET MALIBU CLASSIC 2008

- 1 Disconnect the negative battery terminal to prevent an accidental short circuit.
- 2 Unclip and remove wood grain/painted trim pieces from both sides of steering wheel. **(Figure A)**
- 3 Unclip and remove side panel from driver's side of dash with door open and remove (2) 7MM screws. **(Figure B)**
- 4 Remove (2) 7MM screws from bottom edge of panel below steering wheel. Unclip panel and let hang. It is not necessary to completely remove panel. **(Figure C)**
- 5 Unclip and remove wood grain/painted trim pieces from above glove box. **(Figure D)**

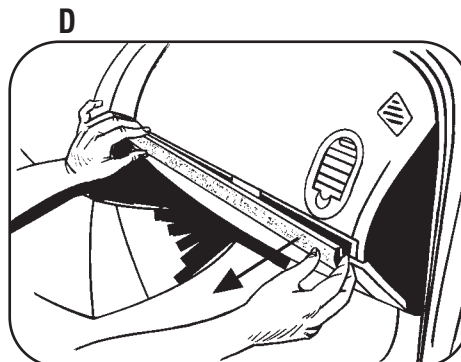
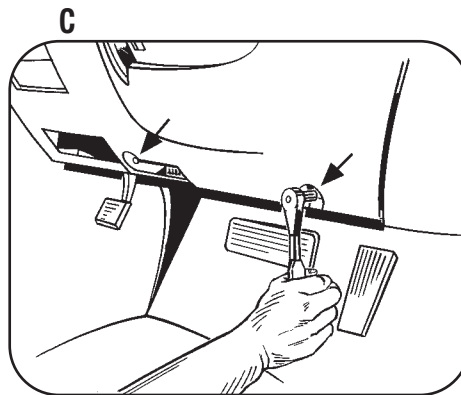
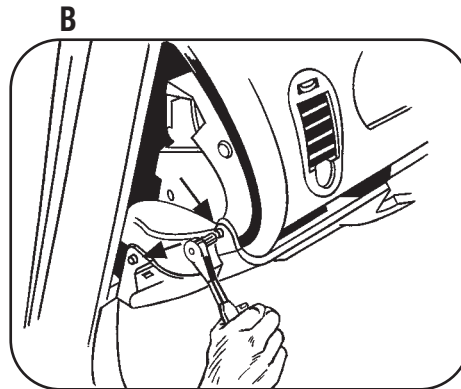
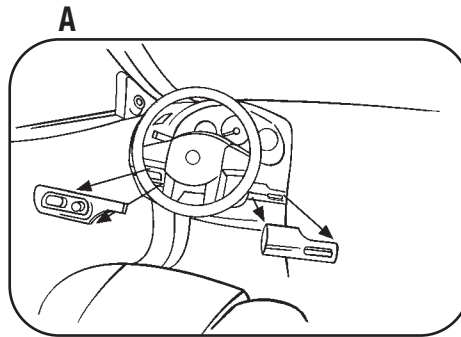

DASH DISASSEMBLY

DASH DISASSEMBLY

CHEVROLET MALIBU 2004-2007 CHEVROLET MALIBU CLASSIC 2008

6 Unclip and remove side panel from passenger side of dash with door open and remove (2) 7 MM screws from behind panel. **(Figure E)**

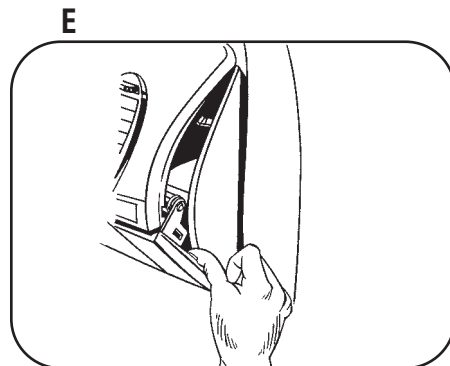

7 Remove (2) 7 MM screws from bottom of glove box then open box and squeeze sides together to open further and remove the remaining (4) 7MM screws. Unclip the black vent cover under the glove box then unclip and remove entire glove box assembly. **(Figure F)**

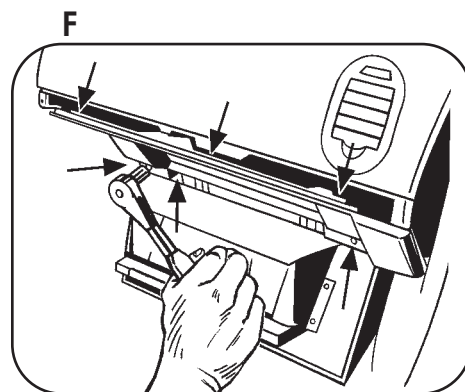

8 Unclip and remove trim panel surrounding radio and climate controls. **(Figure G)**

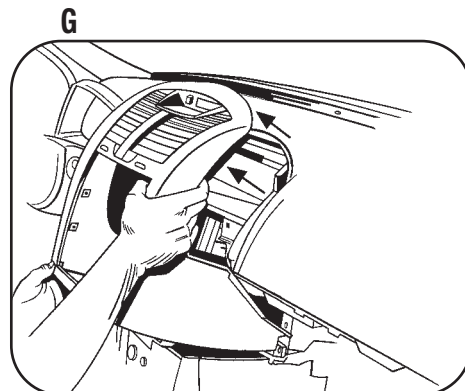

9 Remove (4) 7MM screws from the radio and (2) 7MM screws from climate control to remove radio. **(Figure H)**

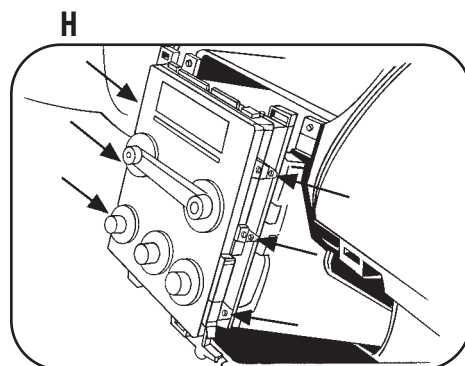

PONTIAC G6 2005-2009

1 Disconnect the negative battery terminal to prevent an accidental short circuit.

2 Open glove box and remove (6) screws from outer edge then unclip and remove box.

(Figure A)

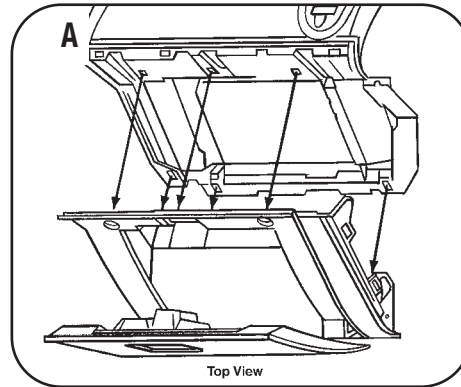

3 Remove (4) screws from panel below steering column and unclip and remove panel.

(Figure B)

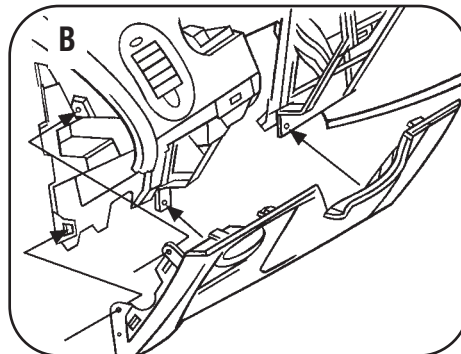

4 Unclip and remove center panel surrounding radio and A/C controls. **(Figure C)**

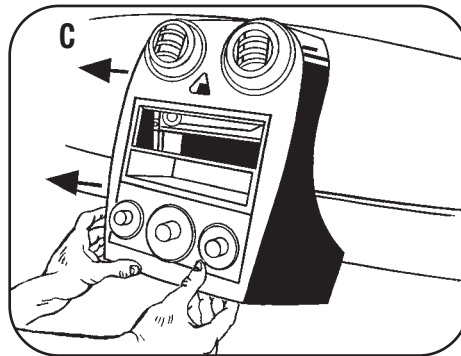

5 Remove (4) screws and extract radio from sub dash. **(Figure D)**

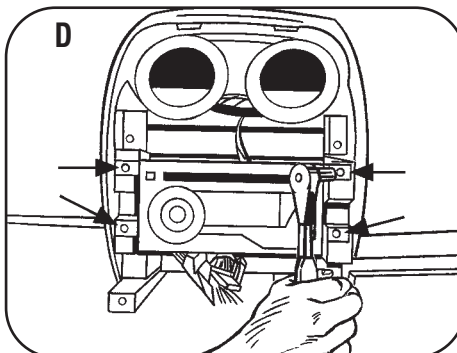

DASH DISASSEMBLY

CHEVROLET COBALT 2005-2006

- 1 Disconnect the negative battery terminal to prevent an accidental short circuit.
- 2 Unclip and remove trim panel from above glove box. **(Figure A)**
- 3 Unclip upper edge of panel below steering column and let hang. Not necessary to remove completely. **(Figure B)**
- 4 Unclip and remove small trim panel to right of ignition switch. **(Figure C)**
- 5 Unclip and remove trim panel surrounding radio and climate controls. **(Figure D)**
- 6 Remove (4) 9/32 screws securing radio. **(Figure E)**

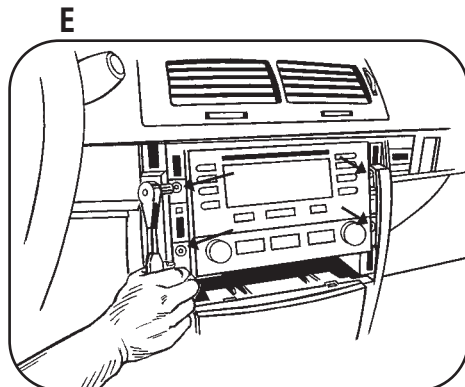
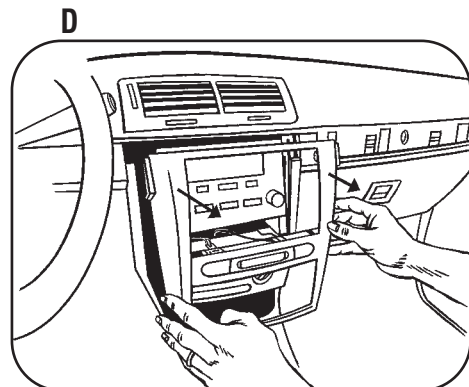
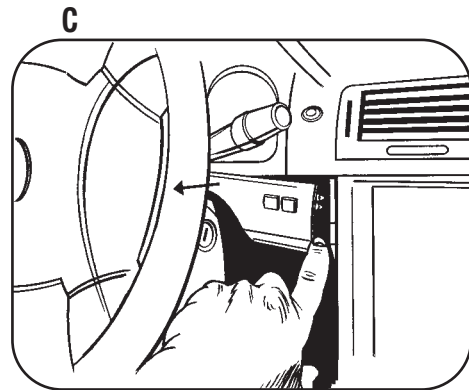
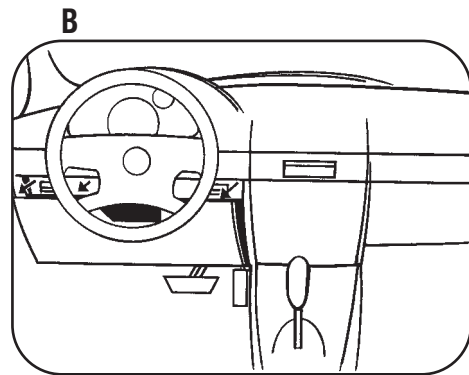
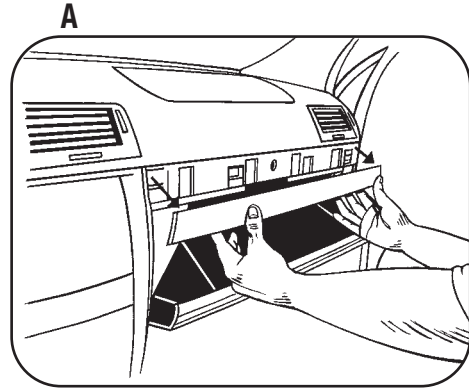

99-3303

DIN HEAD UNIT PROVISIONS:

- 1 Slide the DIN cage into the Radio Housing and secure by bending the metal locking tabs down. **(Figure A)**
- 2 Slide the aftermarket head unit into the cage and secure. **(Figure B)**

NOTE:

A snap-in DIN spacer has been provided for some applications where depth is an issue. Snap the spacer in the housing and slide the DIN cage into the assembly and secure by bending the metal locking tabs outward. **(Figure C)**

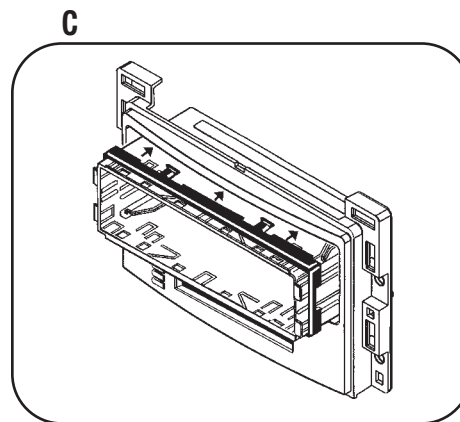
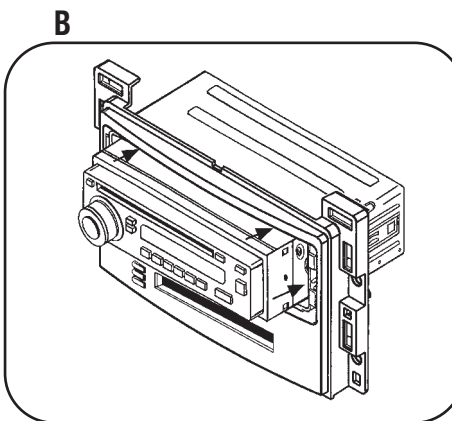
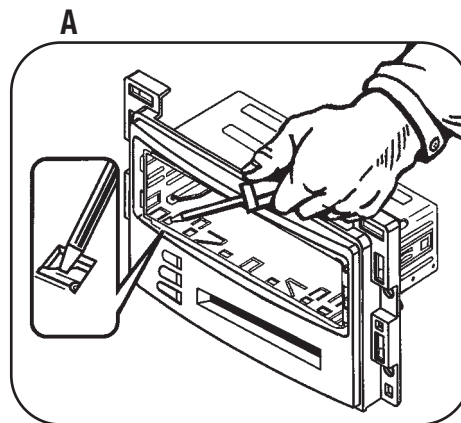

KIT ASSEMBLY

ISO DIN HEAD UNIT PROVISIONS:

- 1 Mount the ISO Brackets to the head unit with the screws supplied with the unit. **(Figure A)**
- 2 Slide the head unit into the radio opening until the side clips engage. **(Figure B)**
- 3 Snap the Trim plate into the Radio Housing. **(Figure B)**

A

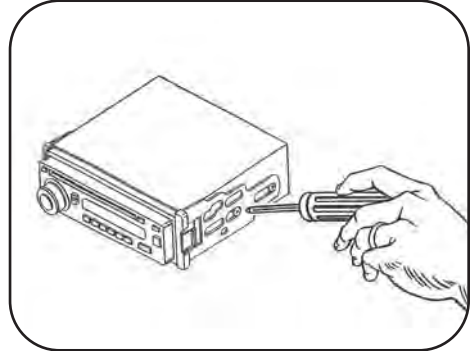

B

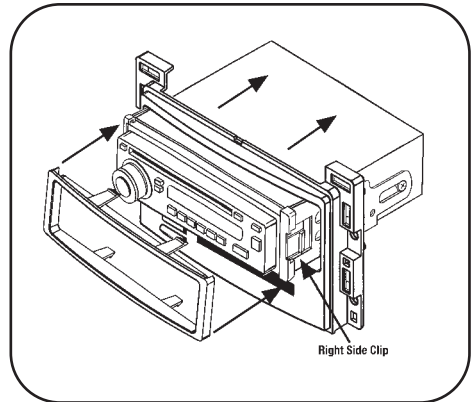

FINAL ASSEMBLY

- 1 Make wiring connections using the EIA color code chart shown below and the instructions included with the head unit. Metra recommends making connections as shown below; Strip, Splice, Solder, Tape. Isolate and individually tape off ends of any unused wires to prevent electrical short circuit.

All connections should be made without the harness plugged into the 99-3303.

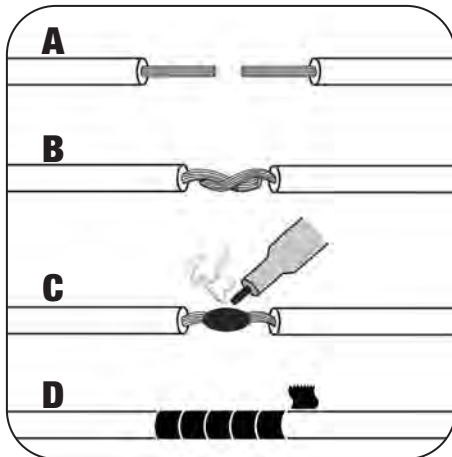

- A) Strip wire ends back 1/2"**
- B) Twist ends together**
- C) Solder**
- D) Tape**

METRA / EIA WIRING CODE

12V Ignition / Acc . . . Red	Right Front (+) Gray
12V Batt / Memory . . Yellow	Right Front (-) Gray / Black
Ground Black*	Left Front (+) White
Power Antenna Blue	Left Front (-) White / Black
Amp Turn-On Blue / White	Right Rear (+) Violet
Amp Ground Black / White	Right Rear (-) Violet / Black
Illumination Orange	Left Rear (+) Green
Dimmer Orange / White	Left Rear (-) Green / Black

***NOTE:** When Black a wire is not present, ground radio to vehicle chassis.
All colors may not be present on all leads due to manufacturer's specifications.

- 2 Plug the clear 10 way and 12 way connectors into the back of the 99-3303 housing.
- 3 Connect the Lt. Blue 24 way connector to the factory 24 way harness.
- 4 On vehicles equipped with Onstar, connect the Black 12 way connector to the factory 12 way harness.
- 5 Re-connect the negative battery terminal and test the unit for proper operation.
- 6 Reassemble dash in reverse order of disassembly.



OPERATION OF THE 99-3303

Settings and Adjustments mode

There is a Settings and Adjustments mode available for the individualized adjustment of the contrast of the display, brightness of the display and backlighting, OnStar volume, and the button backlighting color.

Entering the Settings and Adjustments mode

To enter the Settings and Adjustments mode, press the INFO and MENU buttons simultaneously. When the unit settings and adjustments mode is entered, the LCD will display “Func Sel MENU.”

Selecting a Function to Update

When the unit is in the Settings and Adjustment mode, use the MENU button to select a function to update. The LCD will display the selected function. **See Table 1.0**

Updating a function

While in the Settings and Adjustment mode, use the INFO and ENTER buttons to adjust the function selected and displayed on the LCD. **See Table 1.0**

**** When OnStar activated, INFO and ENTER can be used to adjust the OnStar volume without first entering the settings and adjustments mode.**

Exiting the unit settings and adjustments mode

The unit will automatically exit the settings and adjustments mode if no buttons are pressed for about 10 seconds.

Table 1.0

Function	LCD Display	Description of Operation
LCD Contrast	Contrast INF/ENT	INFO increases LCD contrast ENTER decreases LCD contrast
LCD Brightness	Bright INF/ENT	INFO increases LCD brightness ENTER decreases LCD brightness
OnStar Volume	OnSt Vol INF/ENT	INFO increases OnStar Volume ENTER decreases OnStar Volume
Button Backlighting Color	Button Color ENT	ENTER changes the button backlighting between Amber and Green

INST993303



1-800-221-0932



www.metraonline.com

Rev. 05-27-09 © COPYRIGHT 2004-2009 METRA ELECTRONICS CORPORATION INST99-3303