



## INSTALLATION INSTRUCTIONS FOR PART 99-3527

### APPLICATIONS

# Pontiac Grand Prix 2004-2008

# 99-3527

#### KIT FEATURES

- DIN Head Unit Provision with Pocket
- ISO DIN Head Unit Provision with Pocket



#### KIT COMPONENTS

(A) Radio Housing • (B) Trim Plate • (C) ISO Brackets

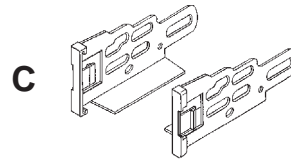
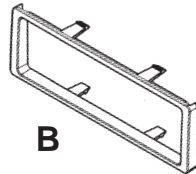
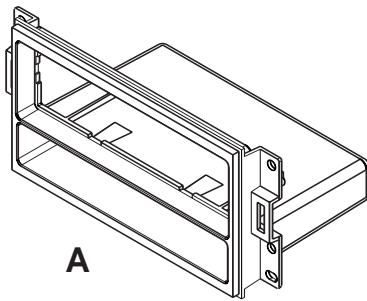

#### WIRING AND ANTENNA CONNECTIONS (Sold Separately)

##### Wire harnesses:

GMOS-01 GM interface 2002-up

GMOS-04 GM amplified interface 2002-up

##### Antenna adapter:

- 40-GM10 - GM antenna adapter 1988-up

#### TOOLS REQUIRED:

Phillips Screwdriver • Socket Wrench

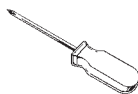

1-800-221-0932



[www.metraonline.com](http://www.metraonline.com)

© COPYRIGHT 2004-2009 METRA ELECTRONICS CORPORATION

# **TABLE OF CONTENTS**

---

***Dash Disassembly***

***2004-2008 Pontiac Grand Prix ..... 1***

***Kit Assembly***

***DIN Head Unit Provision with Pocket ..... 2***

***ISO DIN Head Unit Provision with Pocket ..... 3***

***Final Assembly ..... 4***



**KNOWLEDGE IS POWER**

Enhance your installation and fabrication skills by enrolling in the most recognized and respected mobile electronics school in our industry. Log onto [www.installerinstitute.com](http://www.installerinstitute.com) or call 800-354-6782 for more information and take steps toward a better tomorrow.

## PONTIAC GRAND PRIX 2004-2008

- 1 Disconnect the negative battery terminal to prevent an accidental short circuit.
- 2 Remove bezel from around key cylinder. (Figure A)

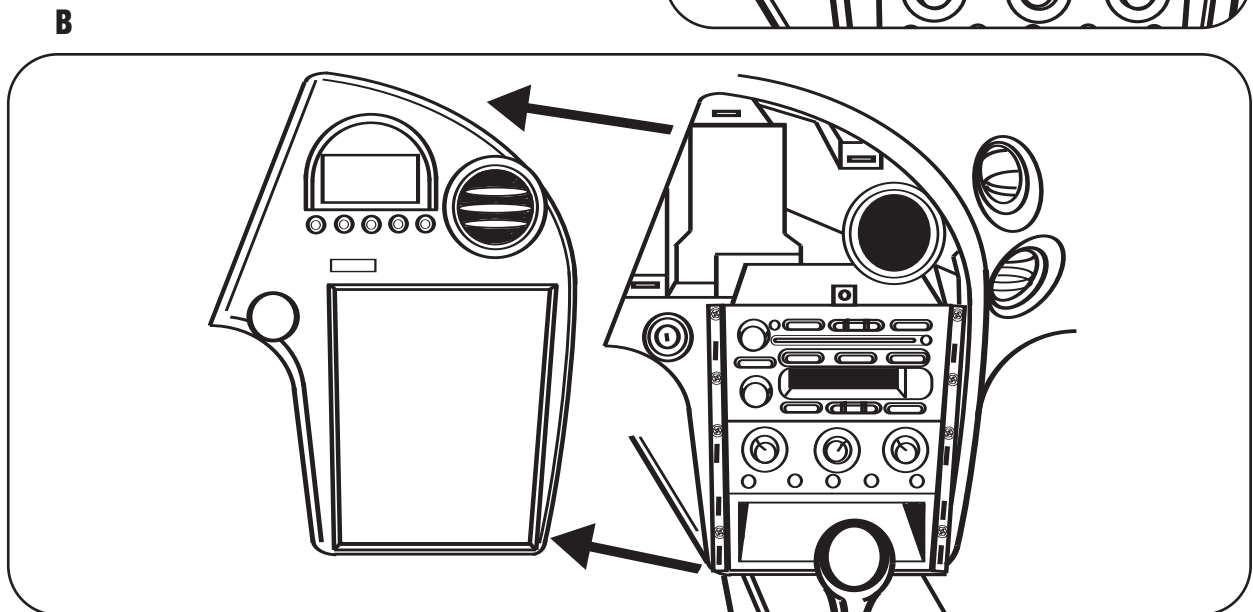
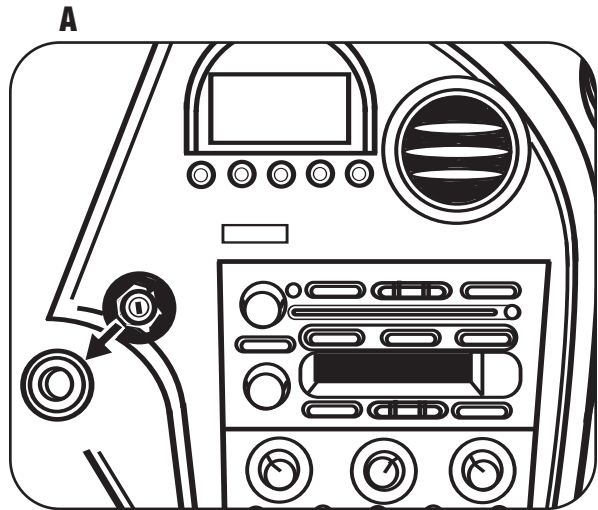

- 3 Unclip and remove entire panel surrounding radio including message center and vents. (Figure B)
- 4 To remove radio start at bottom of stack and remove (8) 9/32" screws from pocket, climate control, and radio (4) on each side). (Figure C)

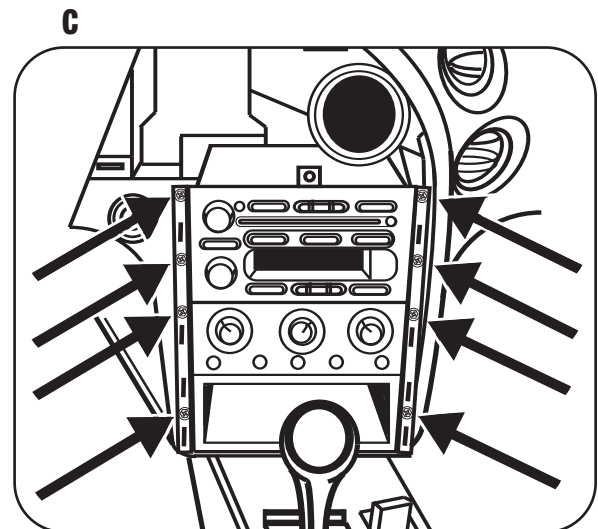

## PONTIAC GRAND PRIX 2004-2008

### DIN HEAD UNIT PROVISION

- 1 Slide the DIN cage into the Radio Housing and secure by bending the metal locking tabs down. (Figure A)
- 2 Slide the aftermarket head unit into the cage and secure. (Figure B)

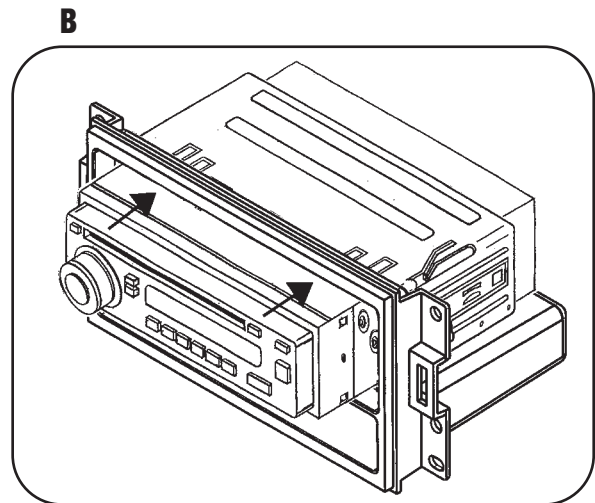
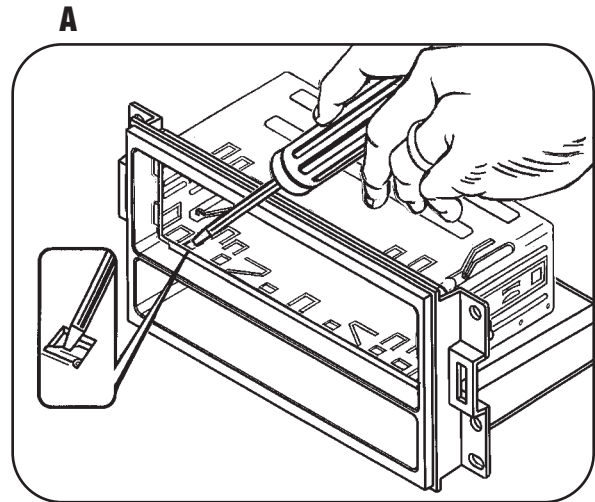

**PONTIAC GRAND PRIX 2004-2008****ISO DIN HEAD UNIT PROVISION**

- 1** Mount the ISO brackets to the radio with the screws supplied with the unit. (Figure A)
- 2** Slide the head unit into the radio opening until the side clips engage. (Figure B)
- 3** Snap the trim plate into the radio housing. (Figure B)

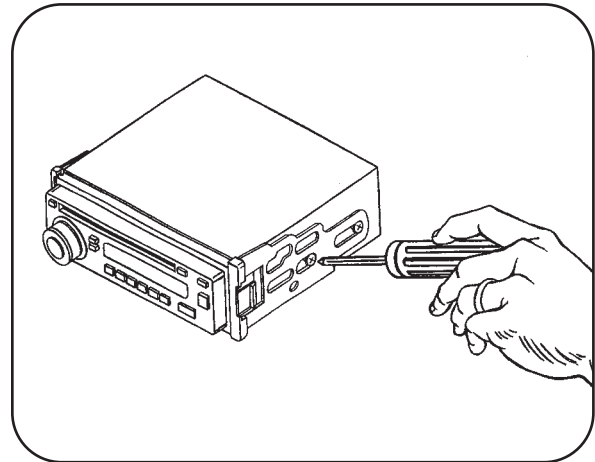
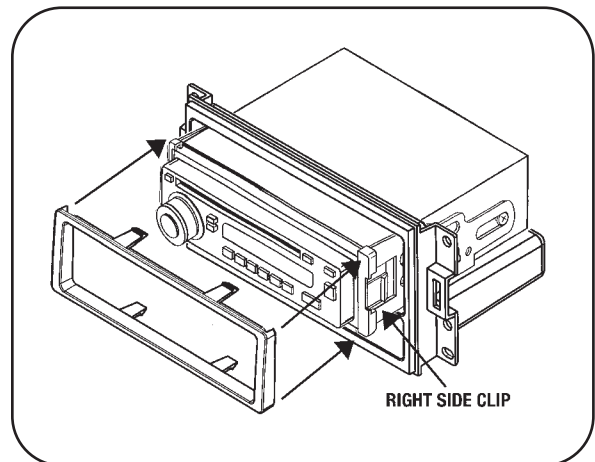
**A****B**

# FINAL ASSEMBLY

- 1** Locate the factory wiring harness in the dash and make the connection as shown. Metra recommends using the proper mating adapter and making the connections as shown. (Isolate and individually tape off the ends of any unused wires to prevent electrical short circuit.)
- 2** Re-connect the negative battery terminal and test the unit for proper operation.
- 3** Reassemble radio and dash assemblies in reverse order of disassembly.

## FINAL WIRING CONNECTIONS

Make wiring connections using the EIA color code chart shown below and the instructions included with the head unit. Metra recommends making connections as shown below; Strip, Splice, Solder, Tape. Isolate and individually tape off ends of any unused wires to prevent electrical short circuit.

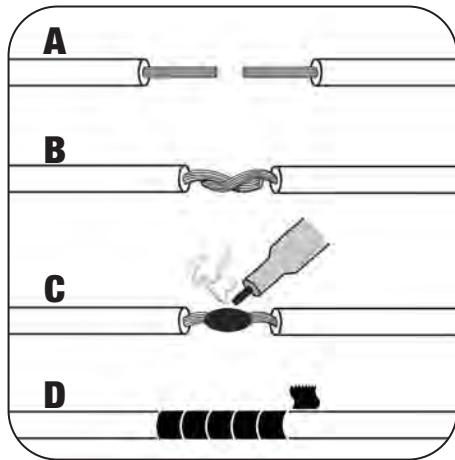

- A) Strip wire ends back 1/2"**
- B) Twist ends together**
- C) Solder**
- D) Tape**

## METRA / EIA WIRING CODE

12V Ignition / Acc . . . Red	Right Front (+) . . . . Gray
12V Batt / Memory . . Yellow	Right Front (-) . . . . Gray / Black
Ground . . . . . Black*	Left Front (+) . . . . . White
Power Antenna . . . . . Blue	Left Front (-) . . . . . White / Black
Amp Turn-On . . . . . Blue / White	Right Rear (+) . . . . . Violet
Amp Ground . . . . . Black / White	Right Rear (-) . . . . . Violet / Black
Illumination . . . . . Orange	Left Rear (+) . . . . . Green
Dimmer . . . . . Orange / White	Left Rear (-) . . . . . Green / Black

**\*NOTE:** When a Black wire is not present, ground radio to vehicle chassis.  
All colors may not be present on all leads due to manufacturer's specifications.



**INST993527**



1-800-221-0932



[www.metraonline.com](http://www.metraonline.com)

REV. 04/17/09

© COPYRIGHT 2004-2009

METRA ELECTRONICS CORPORATION

INST99-3527