



INSTALLATION INSTRUCTIONS FOR PART 99-3528

APPLICATIONS

2004-2006 Pontiac GTO

99-3528



KIT FEATURES

- DIN Head Unit Provisions with Oversized Pocket

KIT COMPONENTS

A) Radio Housing

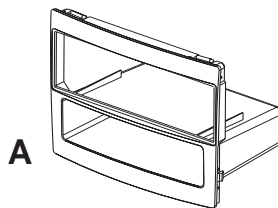

TOOLS REQUIRED:

- 86-3528 Radio Removal Keys • Flat Blade Screwdriver • Phillips Screwdriver

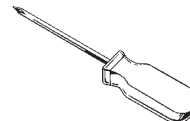
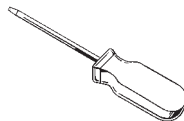
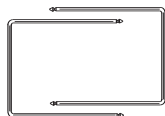

1-800-221-0932



www.metraonline.com

© COPYRIGHT 2004-2008 METRA ELECTRONICS CORPORATION



99-3528

TABLE OF CONTENTS

Dash Disassembly **1-2**

Kit Assembly **3**

Final Assembly **4**

Notes **5**

2004-2006 PONTIAC GTO

1 Disconnect the negative battery terminal to prevent an accidental short circuit.

2 Using the radio removal keys, pull the factory head unit from the dash and disconnect the wiring. (Figure A)

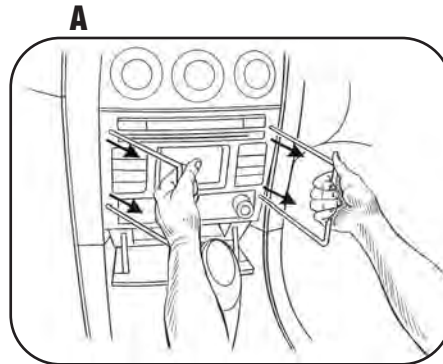

3 Unsnap and remove the trim panel at the top center of the dash above the A/C vents and remove (4) Phillips screws. (Figure B)

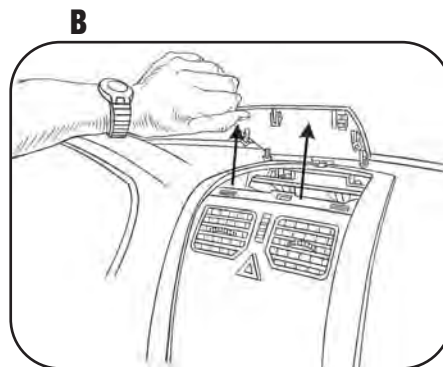

4 Remove (1) Phillips screw from inside lower open storage area where center console and dash meet. (Figure C)

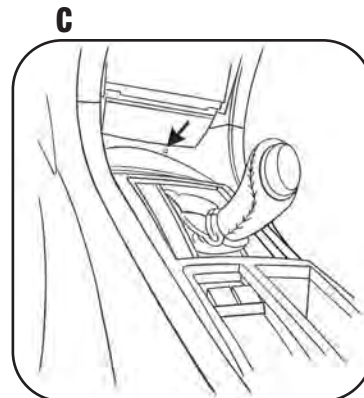

5 Unsnap and remove center console (open center armrest/ storage compartment and work forward). (Figure D)

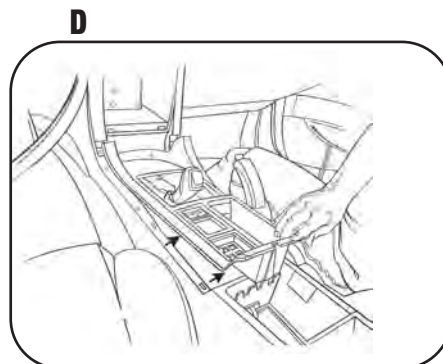

DASH DISASSEMBLY (cont'd)

2004-2006 PONTIAC GTO

- 6 Remove (2) Phillips screws exposed at the bottom of the center panel surrounding radio and remove panel. (Figure E)

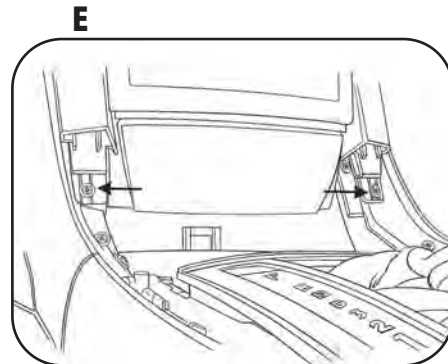

- 7 Unclip and remove trim panel surrounding radio and A/C controls.

- 8 Remove (3) Phillips screws holding "cage" in radio opening. (Figure F)

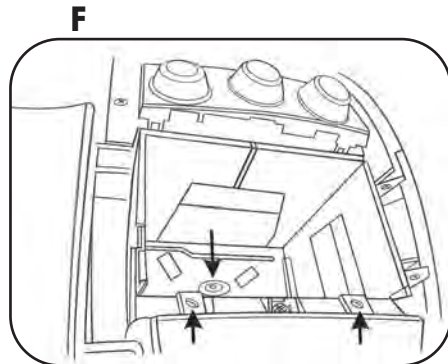

- 9 Pull down on the "cage" from the opening inside on the top and remove. (Figure G)

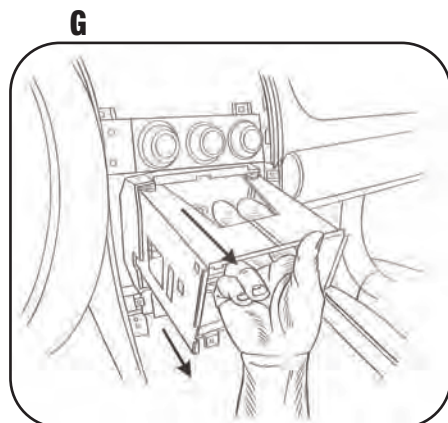

- 1 Slide the DIN cage into the Radio Housing and secure by bending the metal locking tabs down. (Figure A)
- 2 Slide the aftermarket head unit into the cage and secure. (Figure B)

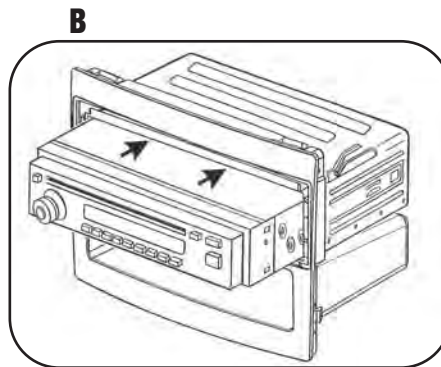
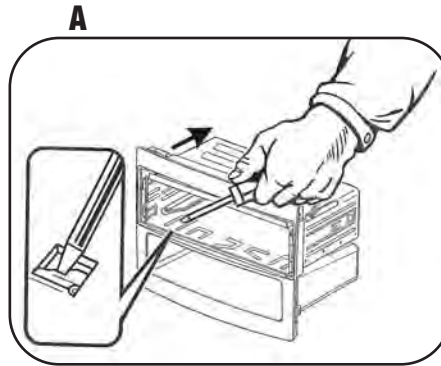

KIT ASSEMBLY

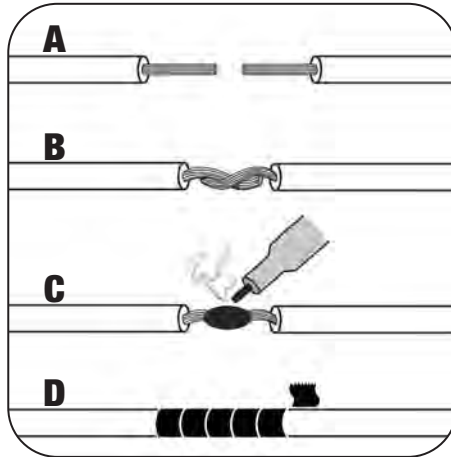
FINAL ASSEMBLY

- A) Strip wire ends back 1/2"**
- B) Twist ends together**
- C) Solder**
- D) Tape**

- 1** Locate the factory wiring harness in the dash. Metra recommends using the proper mating adapter and making the connections as shown. (Isolate and individually tape off the ends of any unused wires to prevent electrical short circuit)
- 2** Re-connect the negative battery terminal and test the unit for proper operation.
- 3** Reassemble in reverse order of disassembly leaving the cage (removed in step 9 of dash disassembly) out and snapping the 99-3528 in place of the factory radio.

INST993528



1-800-221-0932



www.metraonline.com

Rev. 05-07-08 © COPYRIGHT 2004-2008 METRA ELECTRONICS CORPORATION INST99-3528