

KIT FEATURES

- ▶ Shaft and DIN unit provisions
- ▶ Equalizer provisions
- ▶ Rear support provisions



99-5600 AW-560FD INSTALLATION INSTRUCTIONS

APPLICATIONS

KIT COMPONENTS

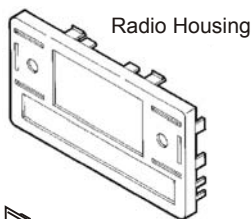

Radio Housing

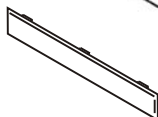

Equalizer
Dummy
Plate



Rear Support
Bracket

TOOLS REQUIRED



86-5618 or AW-FDRT -
Head unit removal keys



Phillips screwdriver



Cutting tool

CAR

PAGE

FORD

Crown Victoria 1995-09.....	1-2
Econoline 1997-08.....	1-2
Explorer 1995-01.....	1-2
Ranger 1995-09.....	1-2

LINCOLN

Continental 1995-97.....	1-2
Mark VIII 1996-98.....	1-2
Town Car 1995-02.....	1-2

MAZDA

B-Series Pickup 1995-09.....	1-2
------------------------------	-----

MERCURY

Grand Marquis 1995-09.....	1-2
Marauder 2003-04.....	1-2
Mountaineer 1997-01.....	1-2

WIRING AND ANTENNA CONNECTIONS (Sold Separately)

Harness:

• Please see www.metraonline.com for specific interface harness

Antenna Adapter:

• 40-CR10 - Chrysler antenna adapter 02-up



KNOWLEDGE IS POWER

Enhance your installation and fabrication skills by enrolling in the most recognized and respected mobile electronics school in our industry. Log onto www.installerinstitute.com or call 800-354-6782 for more information and take steps toward a better tomorrow.

☎ 1-800-221-0932 💻 www.metraonline.com

© COPYRIGHT 2001-09 METRA ELECTRONICS CORPORATION

REV. 08-04-09

ALL VEHICLES

1

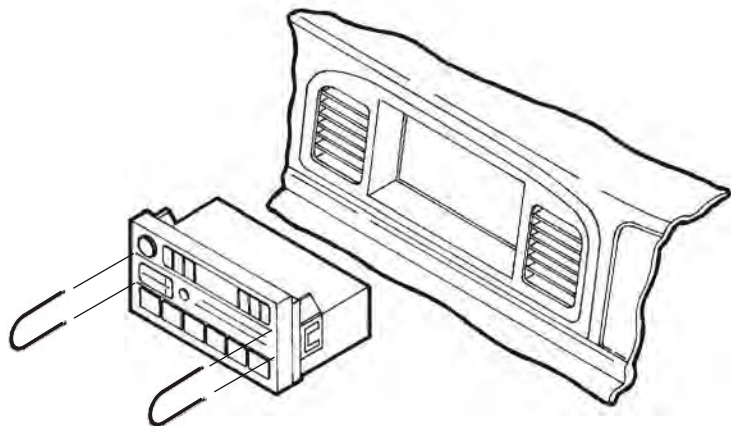

Disconnect the negative battery terminal to prevent an accidental short circuit. Using Metra's 86-5618 or AW-FDRT, pull the factory head unit from the dash and disconnect the wiring.

2

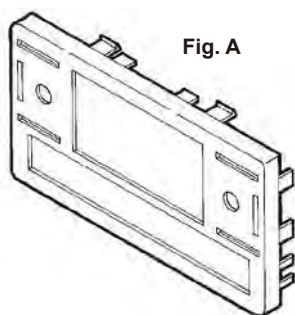

Fig. A

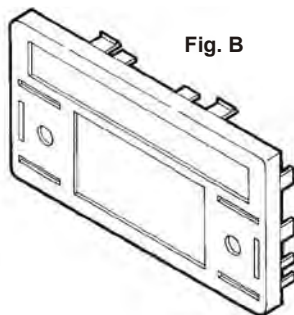
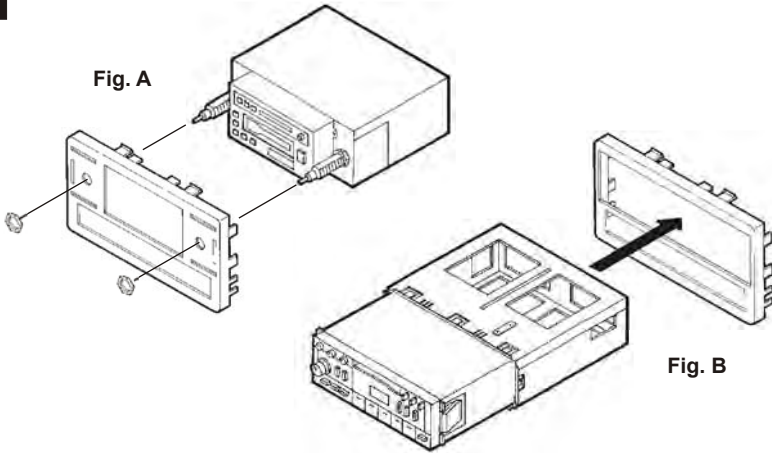

Fig. B

B-SERIES PICKUP, ECONOLINE, EXPLORER, MOUNTAINEER, RANGER: Position the Radio Housing with the radio opening at the TOP for the remainder of the installation. (see Fig. A)

CONTINENTAL, CROWN VICTORIA, GRAND MARQUIS, MARAUDER, MARK VIII, TOWN CAR: Position the Radio Housing with the radio opening at the BOTTOM for the remainder of the installation. (see Fig. B)

3

2-SHAFT HEAD UNITS: Slide the aftermarket head unit into the kit and secure with shaft nuts. (see Fig. A)

DIN HEAD UNITS: Cut and remove the shaft supports from the Radio Housing. Slide the DIN cage into the Housing and secure by bending the metal locking tabs down. Slide the aftermarket head unit into the cage until secure. (see Fig. B)

(If an equalizer will be included, slide the unit into the back of the Radio Housing and secure. If an equalizer will NOT be included, snap the Equalizer Dummy Plate into the opening).

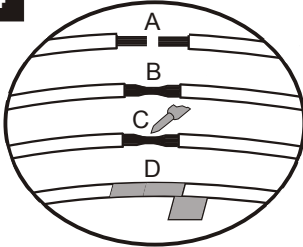
4

- A) Strip wire ends back 1/2"
- B) Twist ends together
- C) Solder
- D) Tape

Locate the factory wiring harness in the dash. Metra recommends using the proper mating adaptor and making connections as shown. (Isolate and individually tape off the ends of any unused wires to prevent electrical short circuit).

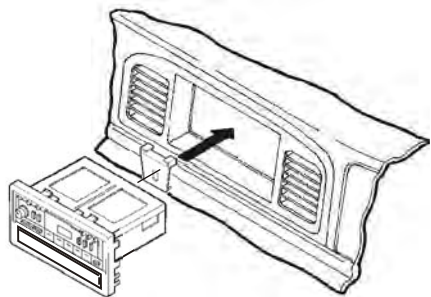
5

Re-connect the battery terminal and test the unit for proper operation. Mount the **Rear Support Bracket** to the back of the unit. Snap the head unit/kit assembly into the sub-dash. (Be sure the Rear Support Bracket engages the support shelf in the dash).