

KIT FEATURES

- ▶ Rear support provisions
- ▶ CD jewel case pocket

KIT COMPONENTS

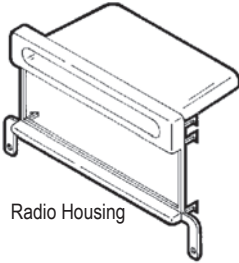

Radio Housing



Mounting Bracket



Rear Support

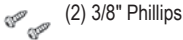

(2) 3/8" Phillips

TOOLS REQUIRED



86-5618 - Head unit removal keys



Phillips Screwdriver



Utility Knife



Adj. Wrench

99-5802 INSTALLATION INSTRUCTIONS

APPLICATIONS

CAR

PAGE

FORD

Crown Victoria 1995-09	1
Econoline 1997-08	1
Escape 2001-07	1
Expedition 1997-02	1
Explorer 1995-01	1
F-150 1997-04	1
F-250 1999-04	1
F-350 1999-04	1
F-550 1999-04	1
Ranger 1995-09	1
Windstar 1999-03	1
Excursion 2000-05	1

LINCOLN

Continental 1995-97	1
Blackwood 2001-03	1
Mark 8 1996-98	1
Town Car 1995-02	1
Navigator 1997-02	1

MAZDA

B-Series Pickup 1995-09	1
-------------------------------	---

MERCURY

Grand Marquis 1995-09	1
Mountaineer 1997-01	1
Marauder 2003-04	1
Mariner 2005-07	1

WIRING AND ANTENNA CONNECTIONS (Sold Separately)

Harness:

- Please see www.metraonline.com for specific interface harness

Antenna Adapter:

- 40-CR10 - Chrysler antenna adapter 02-up



KNOWLEDGE IS POWER

Enhance your installation and fabrication skills by enrolling in the most recognized and respected mobile electronics school in our industry. Log onto www.installerinstitute.com or call 800-354-6782 for more information and take steps toward a better tomorrow.

**FORD Crown Victoria 1995-09 / Econline 1997-08 / Escape 2001-05
 Explorer 1995-01 / F-250 1999-04 / F-350 1999-04 / F-550 1999-04
 Ranger 1995-09 / Windstar 1999-03 / LINCOLN Continental 1995-97
 Mark 8 1996-98 / Towncar 1995-02 / MAZDA B-Series Pickup 1995-09
 MERCURY Grand Marquis 1995-09 / Mountaineer 1997-01
 Mariner 2005-07 / Marauder 2003-04**

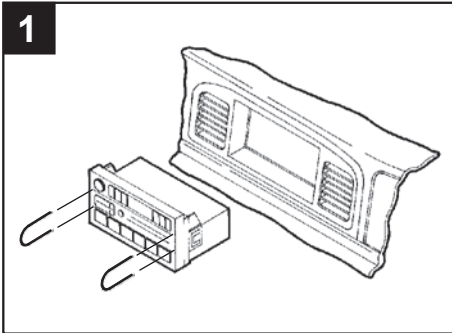

1
 Disconnect the negative battery terminal to prevent an accidental short circuit. Using Metra's 86-5618, pull the factory head unit from the dash and disconnect the wiring.

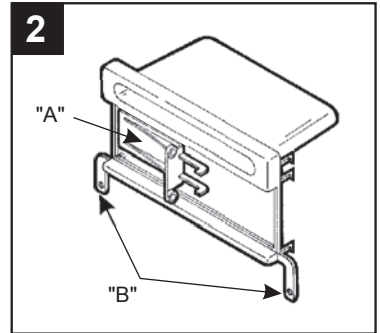

2
 Cut and remove the Mounting Bracket ("A") and the bottom mounting legs ("B") from the Radio Housing. Skip to the Installation Instructions for ALL VEHICLES on Page #2.

**FORD Expedition 1997-00 / F-150 1997-00 / Excursion 2000-05
 LINCOLN Blackwood 2001-03 / Navigator 1997-02**

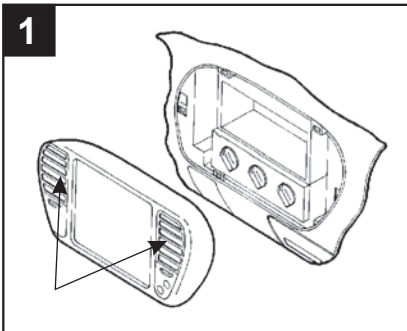

1
 Disconnect the negative battery terminal to prevent an accidental short circuit. Place your index fingers on the inner edges of the a/c vents (shown above) and push inward. Grasp the exposed lip of each vent opening and pull out on the radio trim bezel. Remove the dash trim bezel. (The airbag wiring does NOT need to be disconnected). Using Metra's 86-5618, pull the factory head unit from the dash and disconnect the wiring.

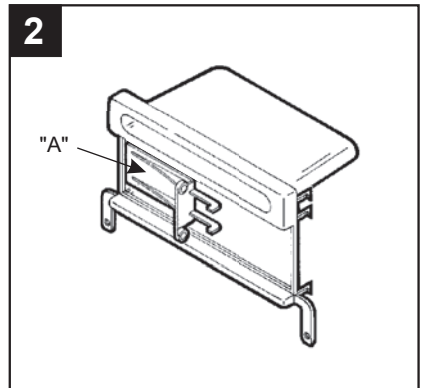

2
 Cut and remove the Mounting Bracket ("A"). Skip to the Installation Instructions for ALL VEHICLES on Page #2.

ALL VEHICLES

3

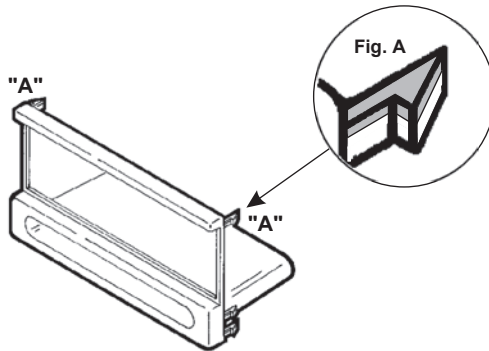

CROWN VICTORIA, GRAND MARQUIS, MARAUDER, TOWNCAR, MARK 8: Skip to step #5.

CONTINENTAL, ECONOLINE, F-150, MOUNTAINEER: Skip to step #4.

B-SERIES PICKUP, EXPEDITION, EXPLORER, F-150, F-250, F-350, F-550, ESCAPE, RANGER, WINDSTAR, EXCURSION, BLACKWOOD, NAVIGATOR, MARINER

Metra recommends installing the kit with the pocket at the top. However, to install the kit with the pocket at the bottom, locate the slots on tabs "A". Using the slots as a guide, cut and remove the shaded portions of the tabs. (see Fig. A)

4

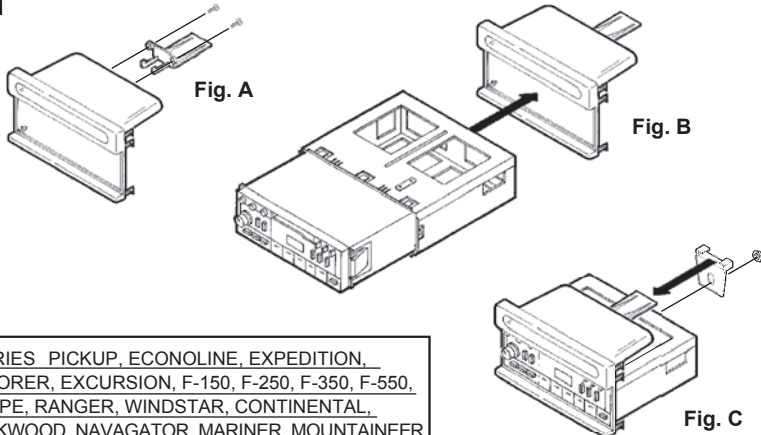

B-SERIES PICKUP, ECONOLINE, EXPEDITION, EXPLORER, EXCURSION, F-150, F-250, F-350, F-550, ESCAPE, RANGER, WINDSTAR, CONTINENTAL, BLACKWOOD, NAVAGATOR, MARINER, MOUNTAINEER

Secure the Mounting Bracket to the back of the Radio Housing with (2) 3/8" Phillips Pan-head Screws supplied. (see Fig. A)

(see Fig. A). Slide the DIN cage into the Radio Housing and secure by bending the metal locking tabs down. Slide the aftermarket head unit into the cage until secure. (see Fig. B). Slide the Rear Support onto the Mounting Bracket and mount the Support to the back of the head unit using the hardware included with the unit. (see Fig. C). Skip to step #6.

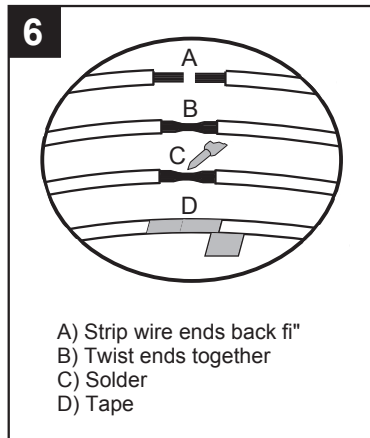
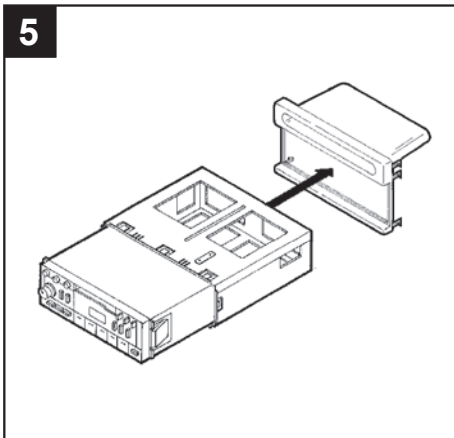

- A) Strip wire ends back 1/2"
- B) Twist ends together
- C) Solder
- D) Tape

CROWN VICTORIA, GRAND MARQUIS, MARAUDER, TOWNCAR, MARK 8: Slide the DIN cage into the Radio Housing and secure by bending the metal locking tabs down. Slide the aftermarket head unit into the cage until secure.

Locate the factory wiring harness in the dash. Metra recommends using the proper mating adaptor and making connections as shown. (Isolate and individually tape off the ends of any unused wires to prevent electrical short circuit).

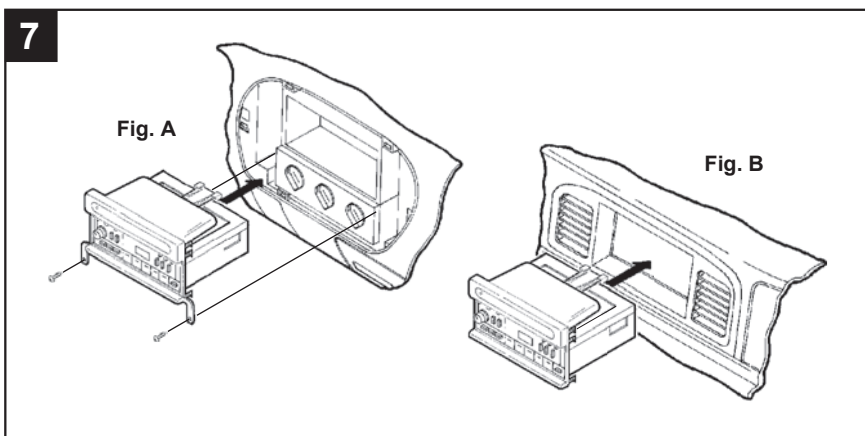

EXPEDITION, F-150, EXCURSION, BLACKWOOD, NAVAGATOR:

Re-connect the battery terminal and test the unit for proper operation.

Remove the top (2) Phillips screws securing the climate control cluster to the sub-dash. Slide the head unit/kit assembly into the dash cavity and mount the bottom legs of the kit to the same holes in the climate control cluster with the (2) Phillips screws previously removed. (see Fig. A)

FORD CROWN VICTORIA, ECONOLINE, ESCAPE, EXPLORER, F-250, F350, F-550, RANGER, WINDSTAR, • LINCOLN CONTINENTAL, MARK 8, TOWNCAR, • MAZDA B-SERIES PICKUP, • MERCURY GRAND MARQUIS, MOUNTAINEER, MARINER, MARAUDER

Re-connect the battery terminal and test the unit for proper operation. Snap the head unit/kit assembly into the sub-dash. (see Fig. B)