



## INSTALLATION INSTRUCTIONS FOR PART 99-7507

### APPLICATIONS

# Mazda 6 2006-2007

# 99-7507



#### KIT FEATURES

- DIN Head Unit Provision
- ISO DIN Head Unit Provision

#### KIT COMPONENTS

A) Radio/Climate Control Housing Assembly • B) ISO Brackets • C) ISO Trim Plate • D) Harnesses

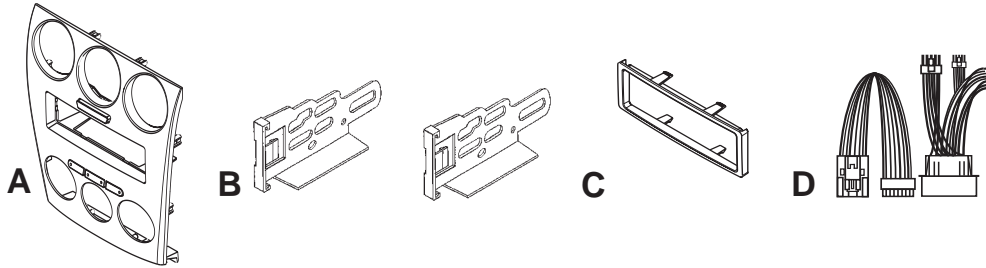

#### TOOLS REQUIRED:

Phillips Screwdriver • Small Flat Blade Screwdriver • Socket Wrench

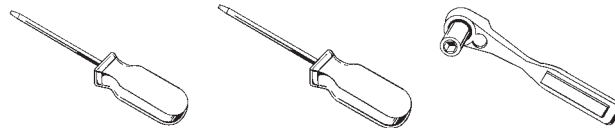

1-800-221-0932



[www.metraonline.com](http://www.metraonline.com)

© COPYRIGHT 2007-2009 METRA ELECTRONICS CORPORATION

# **TABLE OF CONTENTS**

<b><i>Dash Disassembly</i></b> .....	<b>1-5</b>
<b><i>Electronic Climate Control</i></b> .....	<b>1-2</b>
<b><i>Manual Climate Control</i></b> .....	<b>3-5</b>
<b><i>Kit Assembly</i></b> .....	<b>6-8</b>
<b><i>Electronic Climate Control</i></b> .....	<b>6</b>
<b><i>Manual Climate Control</i></b> .....	<b>7-8</b>
<b><i>Felt Tape Application</i></b> .....	<b>9</b>
<b><i>Display Customization</i></b> .....	<b>10</b>
<b><i>Final Wiring and Assembly.</i></b> .....	<b>.11,12</b>



## **KNOWLEDGE IS POWER**

Enhance your installation and fabrication skills by enrolling in the most recognized and respected mobile electronics school in our industry. Log onto [www.installerinstitute.com](http://www.installerinstitute.com) or call 800-354-6782 for more information and take steps toward a better tomorrow.

## MAZDA 6 2006-2007 Electronic Climate Control

- 1 Disconnect the negative battery terminal to prevent an accidental short circuit.
- 2 Unscrew the shift knob counter clockwise to remove. (Figure A)
- 3 Unclip and remove the cup holder/parking brake cover and shifter cover as one unit. (Figure B)
- 4 Remove (2) Phillips screws from the bottom of the radio/climate control panel. (Figure C)
- 5 Open glove box, squeeze sides together and let open fully then remove (1) 10 MM bolt from the side of the radio bracket. (Figure D)

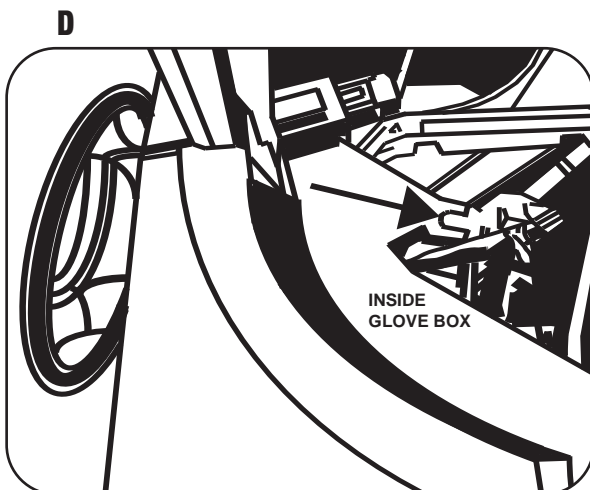
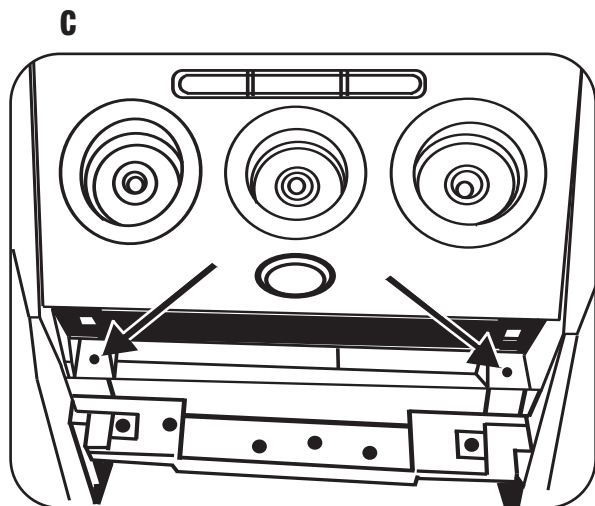
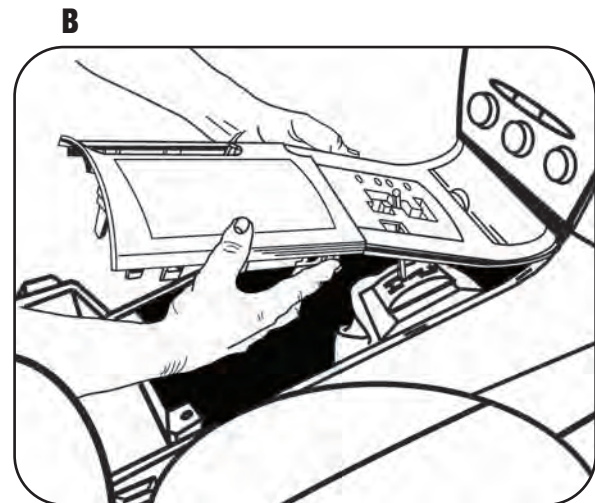
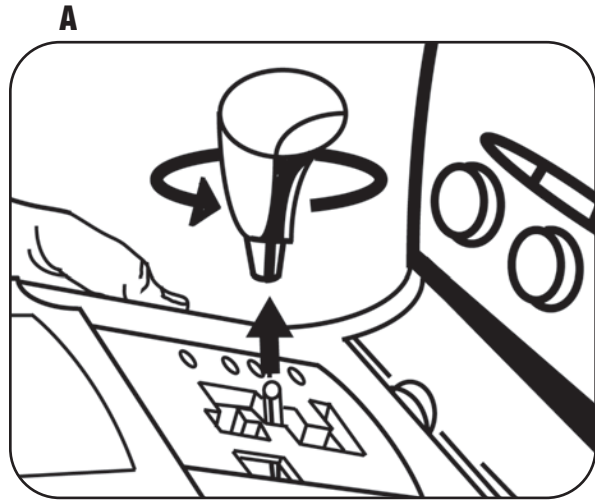

## MAZDA 6 2006-2007 Electronic Climate Control

- 6 Unsnap and remove radio/climate control panel including climate control vents at the top. (Figure E)
- 7 Remove (4) Phillips screws securing vents to radio/climate control panel to remove. (Figure F)
- 8 Remove (8) Phillips screws securing the electronic climate control to the radio/climate control panel to remove. (Figure G)

E

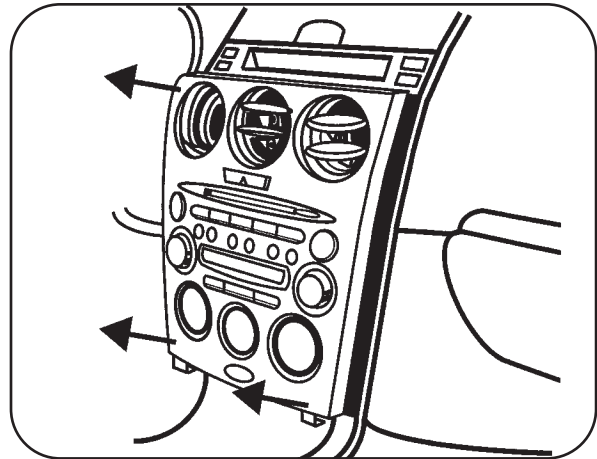

F

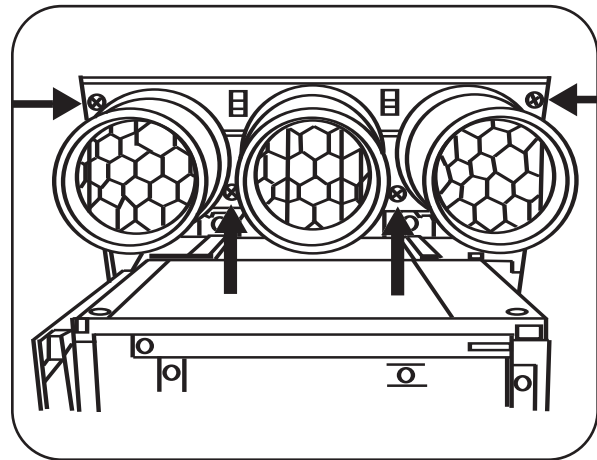

G

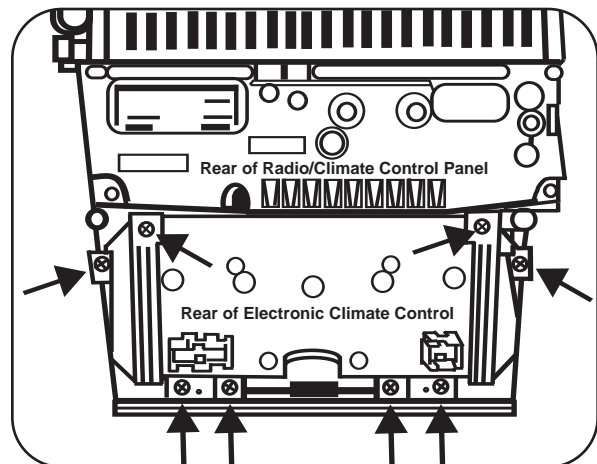

## MAZDA 6 2006-2007 Manual Climate Control

- 1** Disconnect the negative battery terminal to prevent an accidental short circuit.
- 2** Unscrew the shift knob counter clockwise to remove. (Figure A)
- 3** Unclip and remove the cup holder/parking brake cover and shifter cover as one unit. (Figure B)
- 4** Remove (2) Phillips screws from the bottom of the radio/climate control panel. (Figure C)
- 5** Pull the climate control knobs off and remove (2) Phillips screws from behind knobs. (Figure D)

**A**

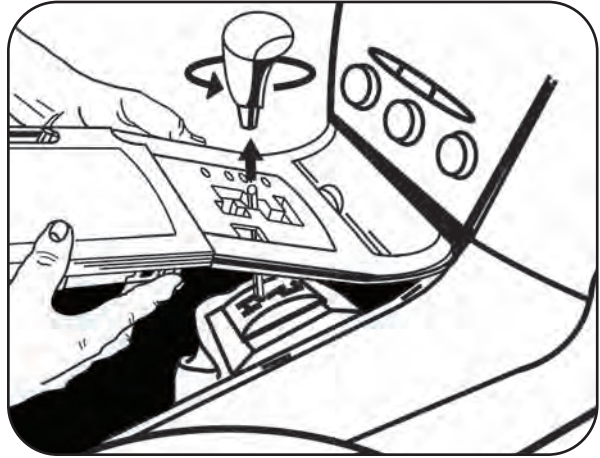

**B**

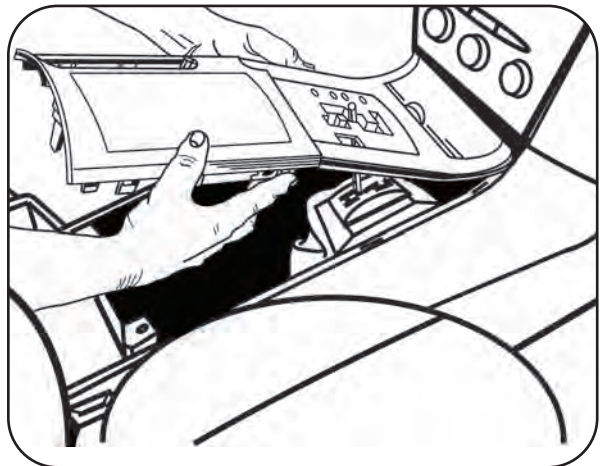

**D**

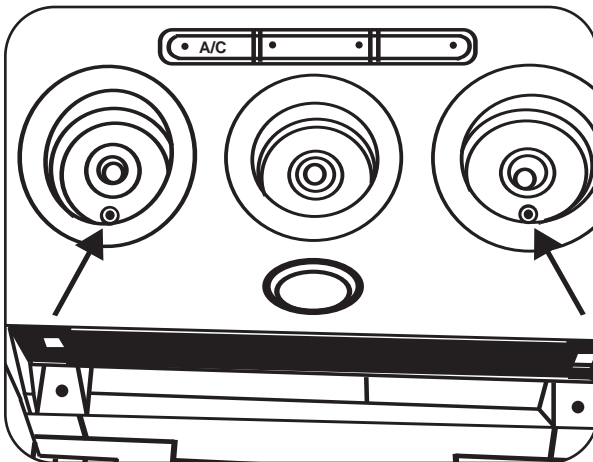

**C**

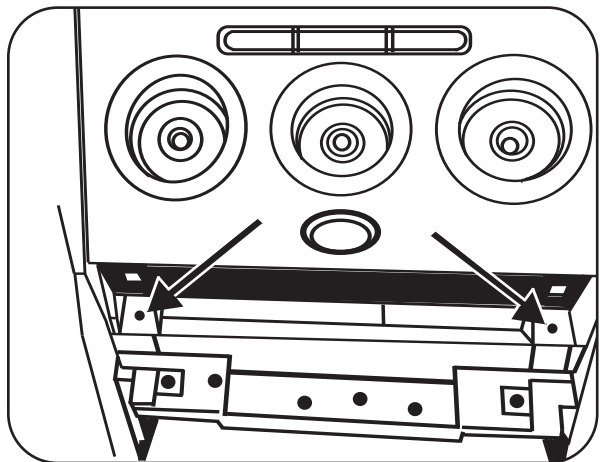

## MAZDA 6 2006-2007 Manual Climate Control

- 6 Open glove box, squeeze sides together and let open fully then remove (1) 10 MM bolt from the side of the radio bracket. (Figure E)
- 7 Unsnap and remove radio/climate control panel including climate control vents at the top. (Figure F)
- 8 Remove (4) Phillips screws securing vents to radio/climate control panel to remove. (Figure G)
- 9 Remove the (2) small Phillips screws securing the light bulb boards on each side of the backlight dispersion bar. **Note:** Notice how they are positioned in the backlight dispersion bar as they will be placed in the 99-7507 the same way. (Figure H)

E

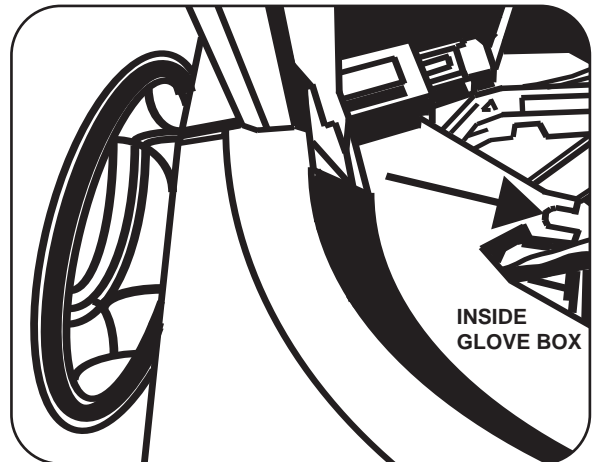

F

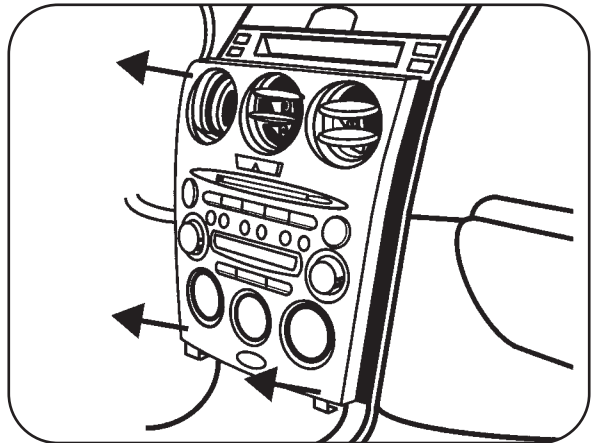

G

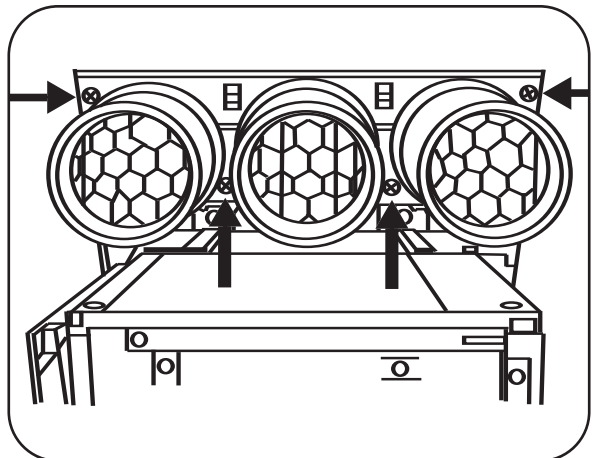

H

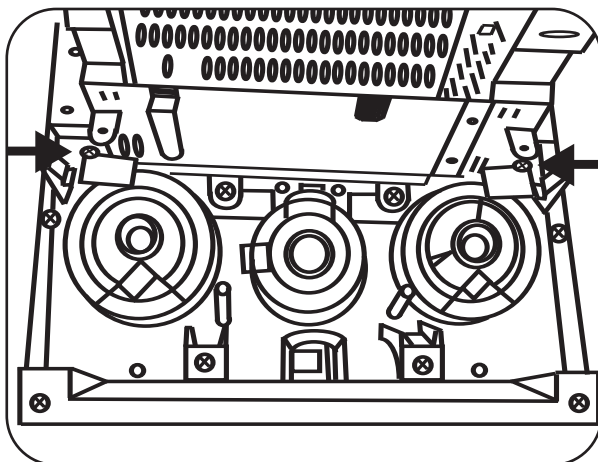



## MAZDA 6 2006-2007 Manual Climate Control

- 10 Remove (4) Phillips screws securing backlight dispersion bar and knob trim bezels. (Figure I)
- 11 Push the bottom edges of the knob trim bezels from the front side to the back and slide both pieces out as one unit. (Figure J)

I

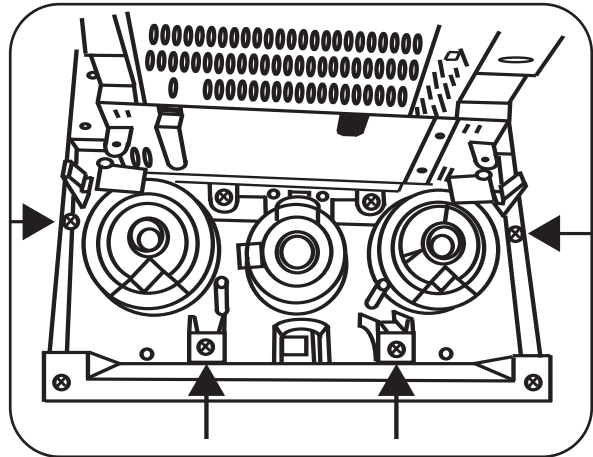

J

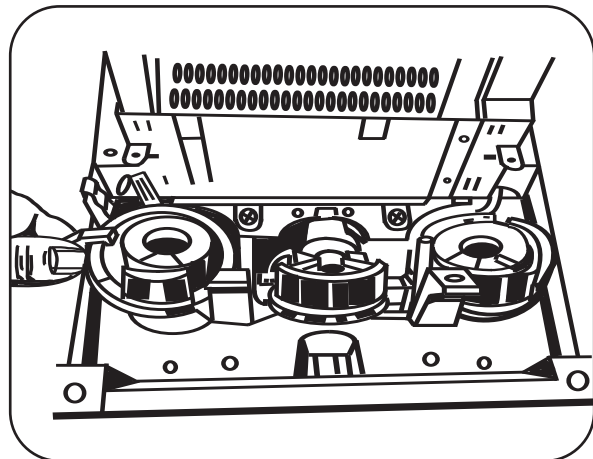

## MAZDA 6 2006-2007 Electronic Climate Control

- 1 Clip the climate control knob outer trim ring panel into the 99-7507 housing. (Figure A)
- 2 Align the screw holes in the climate control and the radio housing panel then push the climate control onto the radio housing panel. (Figure B)
- 3 Secure the climate control with the factory hardware removed in step 8 of the dash disassembly for electronic climate control cars.
- 3 Unclip and remove the small oval cover plate at the bottom center of the factory radio and insert into the 99-7507 radio housing. (Figure C)

**Note:** The 16 position to 16 position harness supplied with the 99-7507 will **NOT be used** in vehicles with **electronic climate controls**. (Figure D)

A

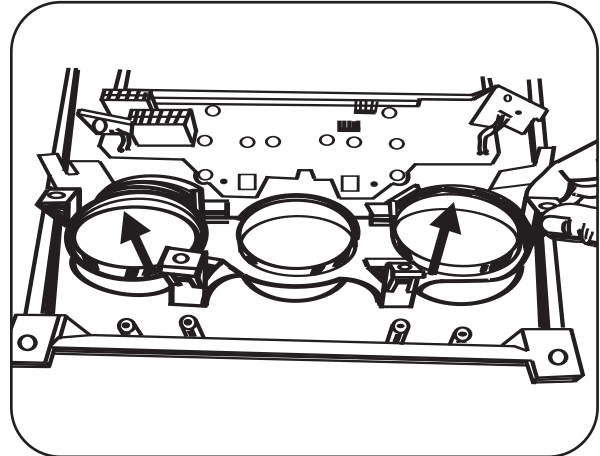

B

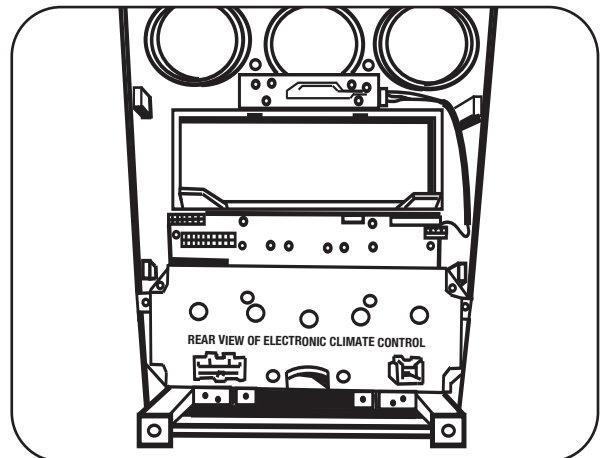

D

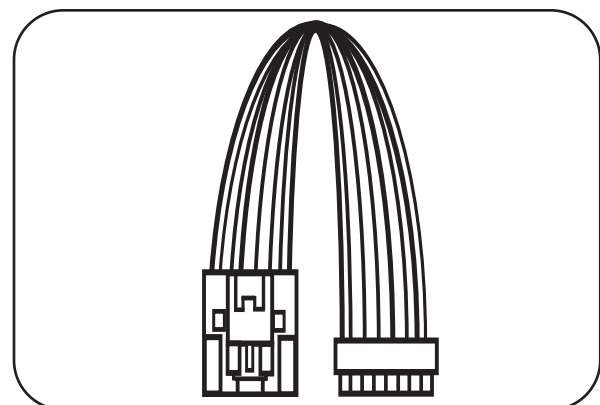

**NOTE:** This 16 to 16 position harness is **NOT USED** with **ELECTRONIC CLIMATE CONTROL** vehicles.

C

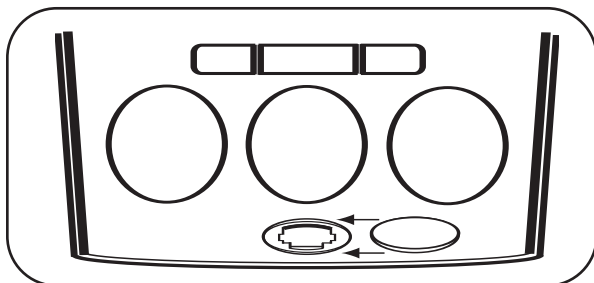



## MAZDA 6 2006-2007

### Manual Climate Control

**1** Put the climate control knob outer trim panel and the backlight dispersion bar together and clip into the radio housing panel as one unit.  
**Note:** You may have to push down slightly on the middle of the unit to ease in positioning it into the kit.  
 (Figure A, B, C )

**2** Secure the unit with the factory hardware removed in step 10 of the manual climate control dash disassembly.

**3** Secure the light bulb boards on each side of the backlight dispersion bar using the factory hardware removed in step 9 in manual climate control dash disassembly. (Figure D )

**4** Unclip and remove the small oval cover plate at the bottom center of the factory radio and insert into the 99-7507 radio housing. (Figure E)

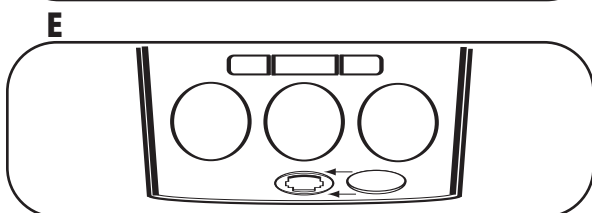
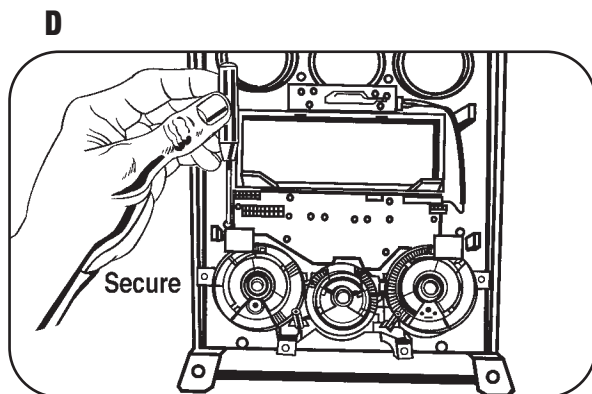
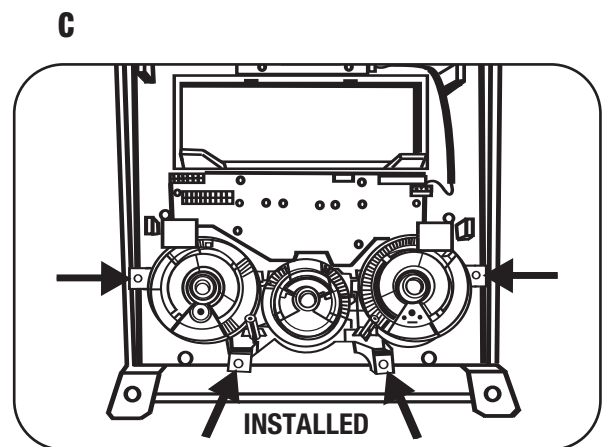
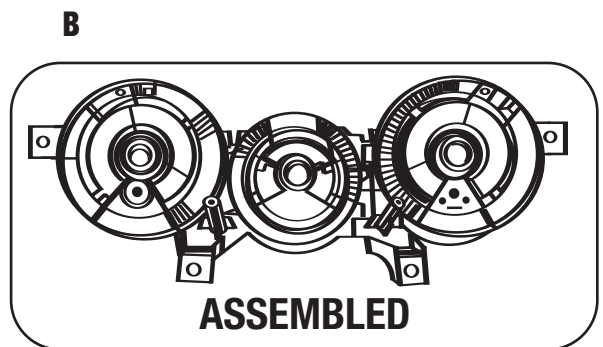
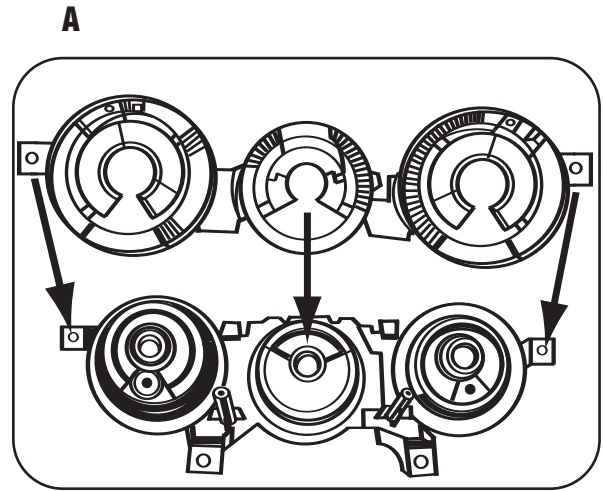

**Note:** The 16 position to 16 position harness supplied with the 99-7507 ***WILL BE USED*** in vehicles with ***MANUAL CLIMATE CONTROLS***. (Figure F)

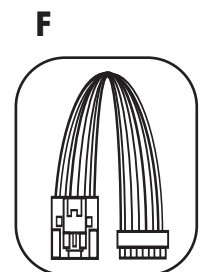

## DIN HEAD UNIT PROVISION

- 1 Slide the DIN cage into the Radio Housing and secure by bending the metal locking tabs down. (Figure A)
- 2 Slide the aftermarket head unit into the DIN cage until secure. (Figure B)

A

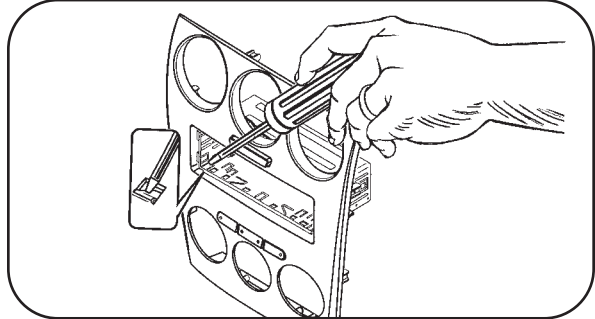

- 3 Snap the Trim plate into the Radio Housing. (Figure B)

B

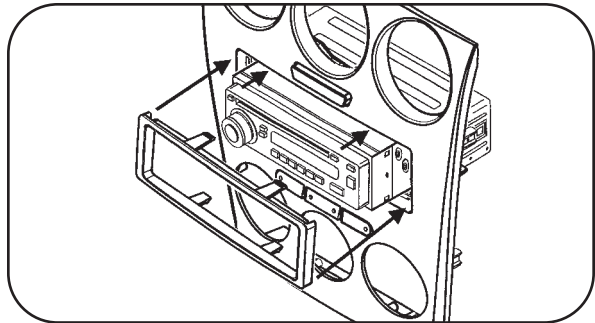

## ISO DIN HEAD UNIT PROVISION

- 1 Mount the ISO Brackets to the head unit with the screws supplied with the unit. (Figure A)
- 2 Slide the head unit into the radio opening until the side clips engage. (Figure B)
- 3 Snap the Trim plate into the Radio Housing. (Figure B)

A

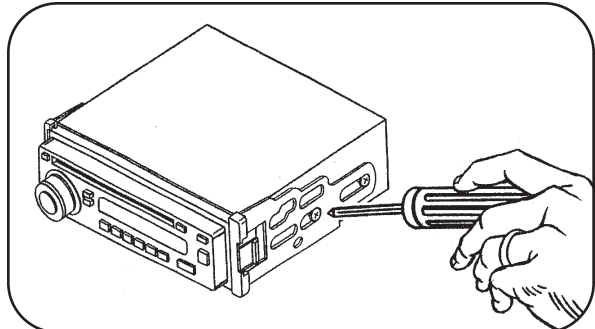

B

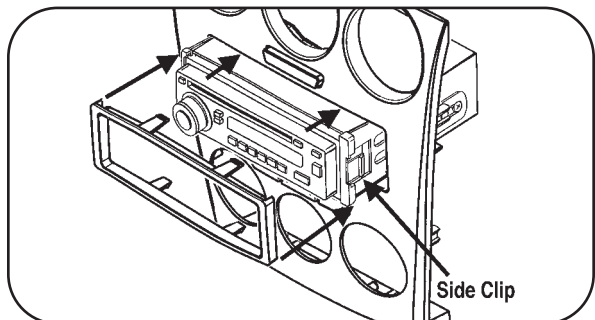

## FELT TAPE APPLICATION

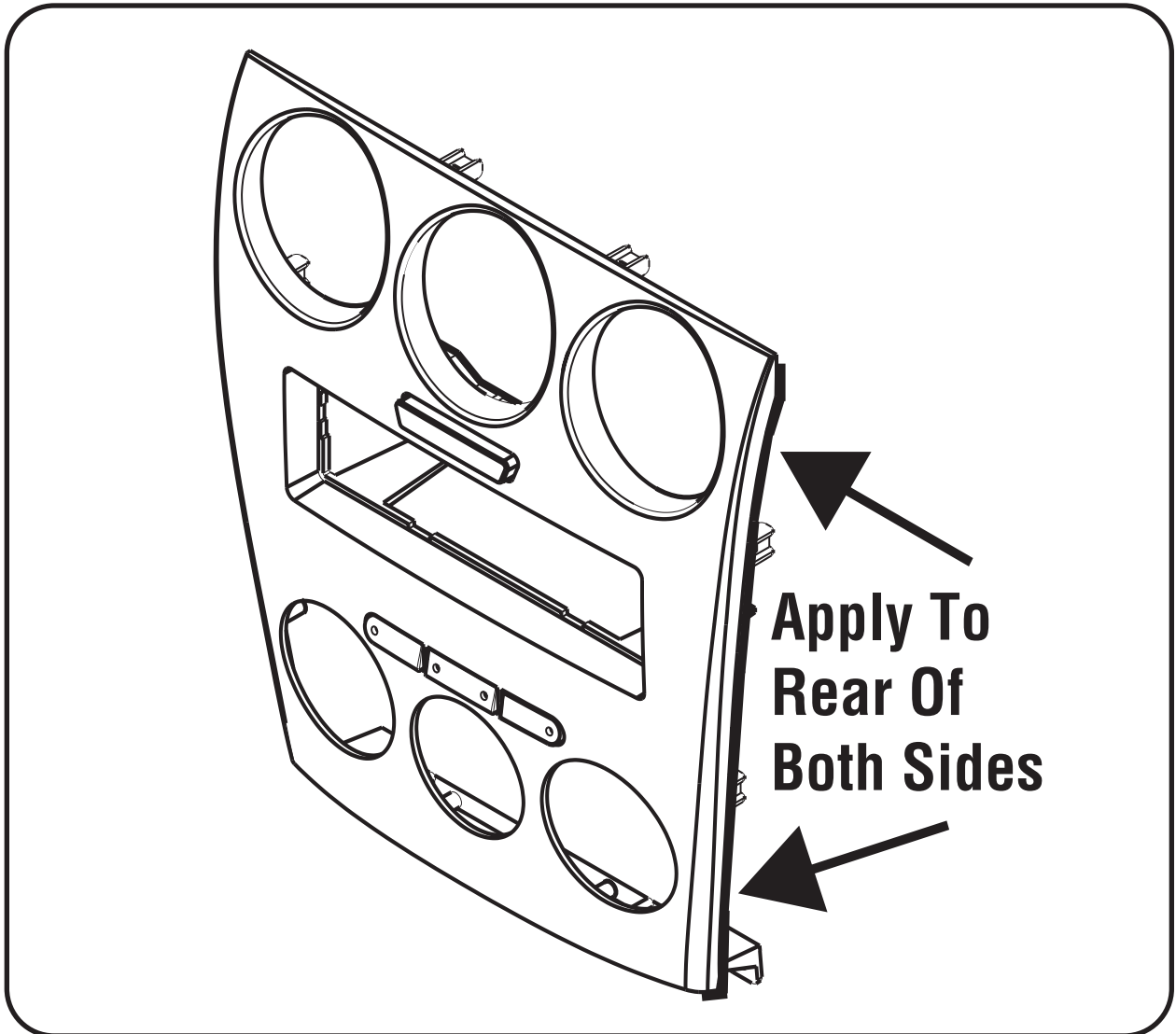

**Note:** Due to differences in factory tolerances you may need to apply the provided felt tape to the edge of the 99-7507 radio housing to relieve backlight bleed through.

1. Looking at edge of radio housing apply felt tape to inner edge (toward back of kit). If it is positioned to closely to the outer edge you may be able to see it once it is in the dash.

## DISPLAY CUSTOMIZATION

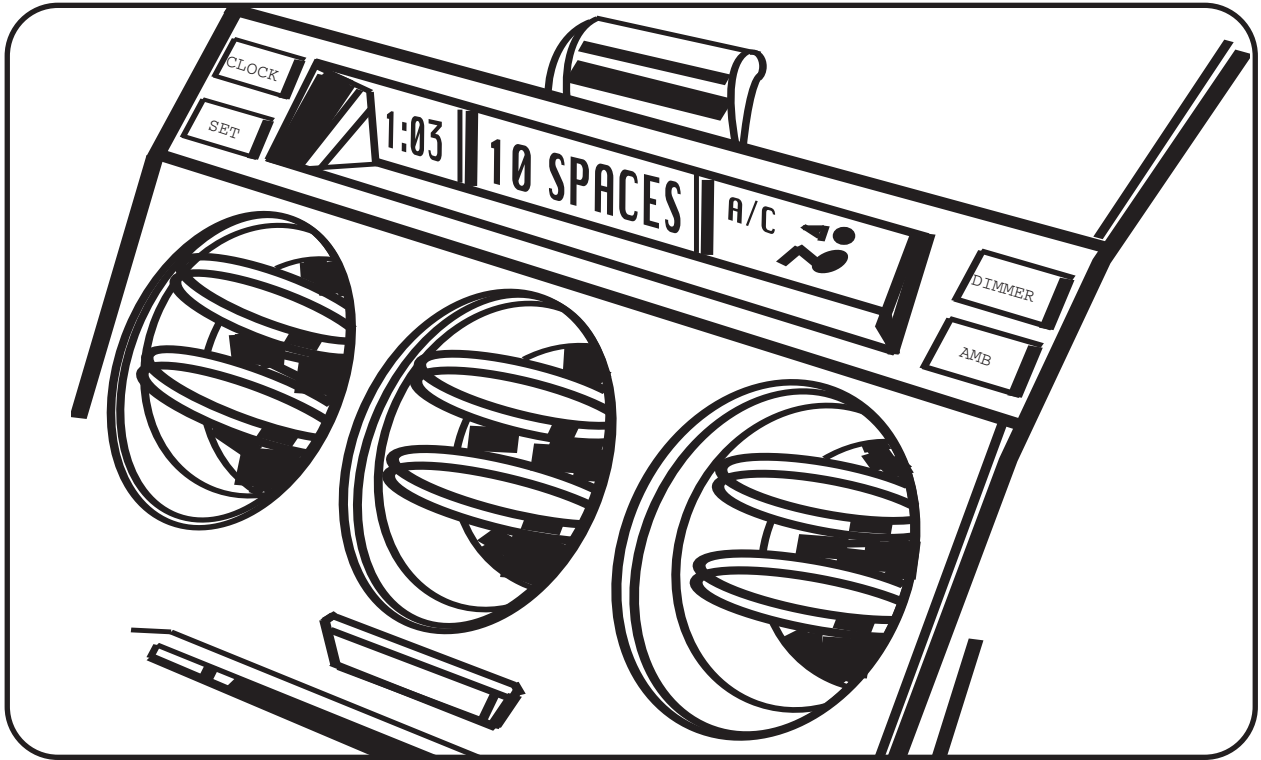

1. Press and hold the **AMB button** on the factory display for 5 seconds then release the button. The first character will be highlighted. Settings will begin with the first character location. Use the **AMB button** to select the desired character then wait. The next character will be highlighted. Press and release to set that character, and keep going until the text is to your liking. There are 10 available character locations.

2. Once the desired text is entered press and hold the **AMB button** for greater than 5 seconds then release and the display will read “**Text Saved.**”

# FINAL WIRING and ASSEMBLY

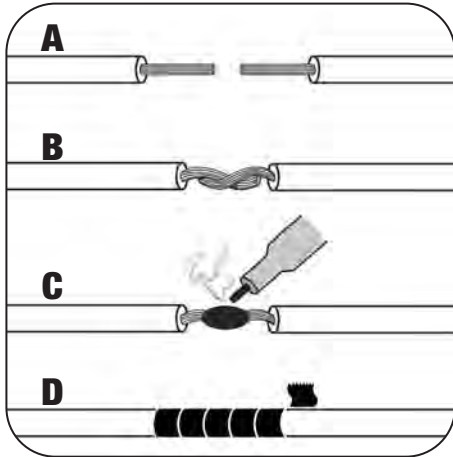

- A) Strip wire ends back 1/2"**
- B) Twist ends together**
- C) Solder**
- D) Tape**

- 1** Locate the factory wiring harness in the dash. Metra recommends using the proper mating adapter and making connections as shown. (Isolate and individually tape off the ends of any unused wires to prevent electrical short circuit.)

## FINAL WIRING CONNECTIONS

Make wiring connections using the EIA color code chart shown below and the instructions included with the head unit. Metra recommends making connections as shown below; Strip, Splice, Solder, Tape. Isolate and individually tape off ends of any unused wires to prevent electrical short circuit.

### METRA / EIA WIRING CODE

12V Ignition / Acc . . . Red	Right Front (+) . . . . Gray
12V Batt / Memory . . Yellow	Right Front (-) . . . . Gray/ Black
Ground . . . . . Black*	Left Front (+) . . . . . White
Power Antenna . . . . . Blue	Left Front (-) . . . . . White / Black
Amp Turn-On . . . . . Blue / White	Right Rear (+) . . . . . Violet
Amp Ground . . . . . Black / White	Right Rear (-) . . . . . Violet / Black
Illumination . . . . . Orange	Left Rear (+) . . . . . Green
Dimmer . . . . . Orange / White	Left Rear (-) . . . . . Green / Black

**\*NOTE:** When a Black wire is not present, ground radio to vehicle chassis.  
All colors may not be present on all leads due to manufacturer's specifications.

## **FINAL WIRING and ASSEMBLY**

- 2** Plug the 5 way connector (supplied with the 99-7507) into location 1 on the back of the 99-7507 housing (see diagram).
- 3** On manual climate control vehicles only, plug the 16 way connector (supplied with the 99-7507) into location 3 on the back of the 99-7507 housing (see diagram). Automatic climate control vehicles will not use this harness.
- 4** Plug the 2 way connector (supplied with the 99-7507) into location 4 on the back of the 99-7507 housing (see diagram).
- 5** Re-connect the negative battery terminal and test the unit for proper operation.
- 6** Reassemble radio and dash assemblies in reverse order of disassembly.

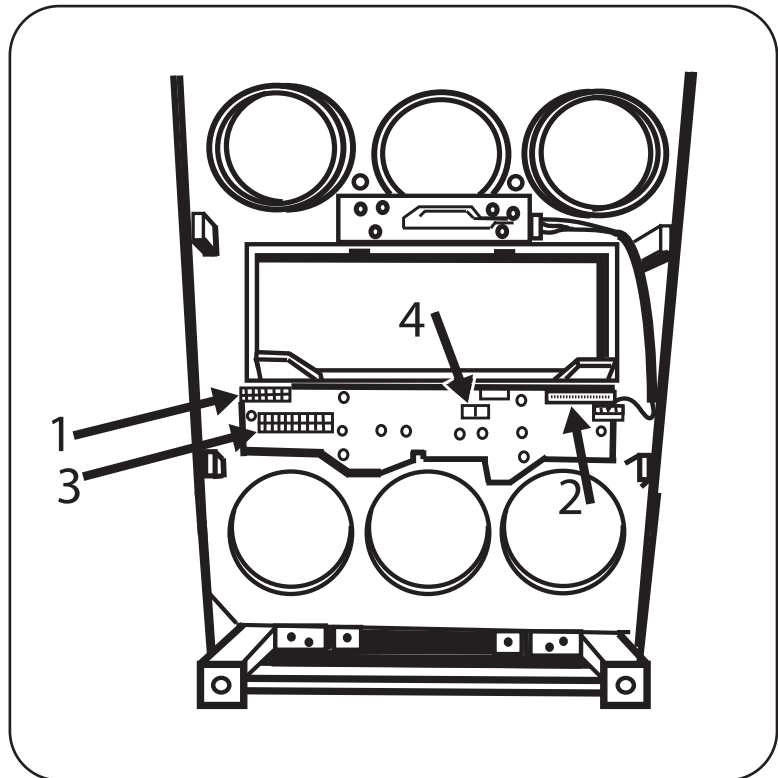

***Note: The connector "2" is not used in this application.***





**INST997507**



1-800-221-0932



[www.metraonline.com](http://www.metraonline.com)

REV. 07/16/09

© COPYRIGHT 2007-2009

METRA ELECTRONICS CORPORATION

INST99-7507