

**KIT FEATURES**

- ▶ ISO-DIN head unit provisions
- ▶ Pocket provisions



# 99-8201

## INSTALLATION INSTRUCTIONS

**KIT COMPONENTS**

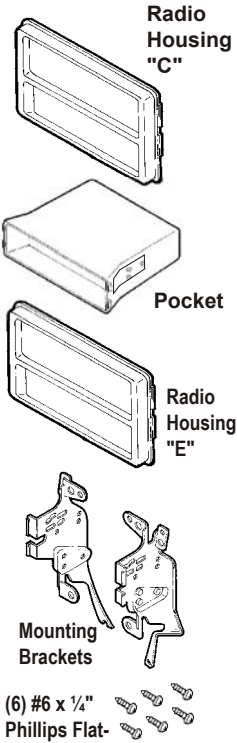

APPLICATIONS

CAR

PAGE

**TOYOTA**

Celica 2000-05.....	1-3
Echo 2000-05.....	1-3



**TOOLS REQUIRED**



## TOYOTA Celica 2000-05

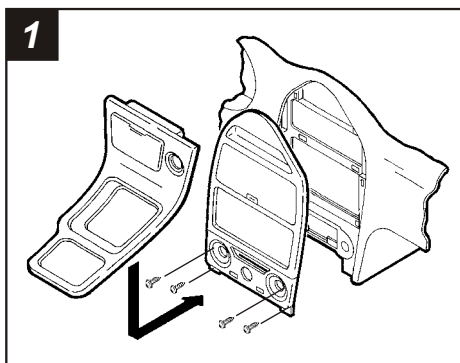

Disconnect the negative battery terminal to prevent an accidental short circuit. Unclip and remove the gear shifter trim bezel and remove (2) Phillips screws exposed below the climate controls. Pull off climate control knobs and remove (2) Phillips screws exposed. Unclip the climate control/factory radio trim bezel and remove. Remove (4) 10mm screws securing the factory head unit and disconnect the wiring.

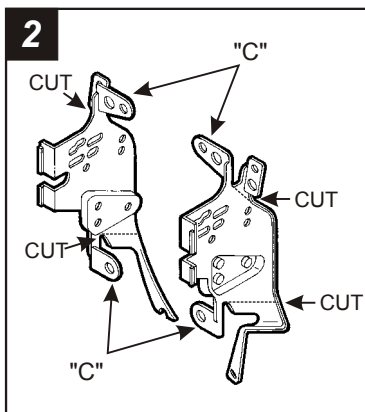

Locate Radio Housing "C". Using the dotted lines as a guide, cut and remove all tabs on the Mounting Brackets EXCEPT tabs "C". Skip to the Installation Instructions for ALL VEHICLES on Page #2.

## TOYOTA Echo 2000-05

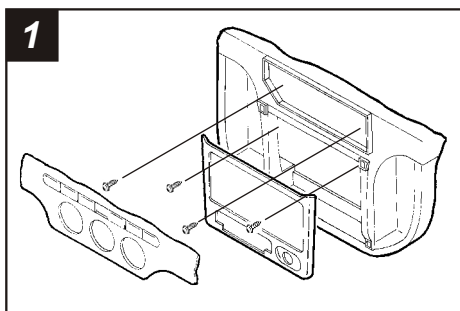

Disconnect the negative battery terminal to prevent an accidental short circuit. Remove the climate control knobs and (2) Phillips screws exposed. Unclip and remove the climate control trim bezel. Depress the side clips securing the climate control panel and move the panel to access (2) Phillips screws from the top of the factory radio brackets. Remove the ashtray. Unclip and remove the radio trim bezel. Remove (2) Phillips screws from the bottom of the radio brackets and disconnect the wiring.

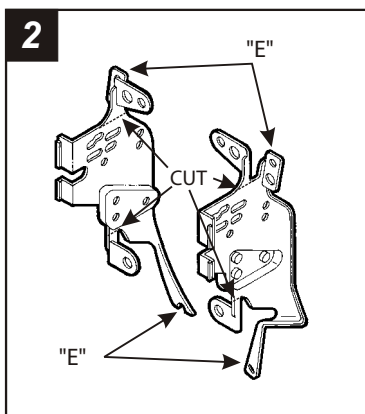

Locate Radio Housing "E". Using the dotted lines as a guide, cut and remove all tabs on the Mounting Brackets EXCEPT tabs "E". Skip to the Installation Instructions for ALL VEHICLES on Page #2.

## ALL VEHICLES

3

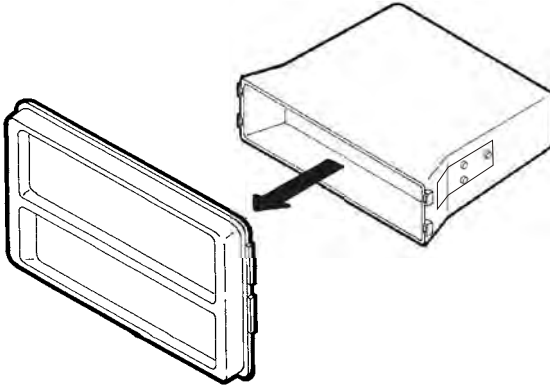

Snap the Pocket onto the back of the Radio Housing.

4

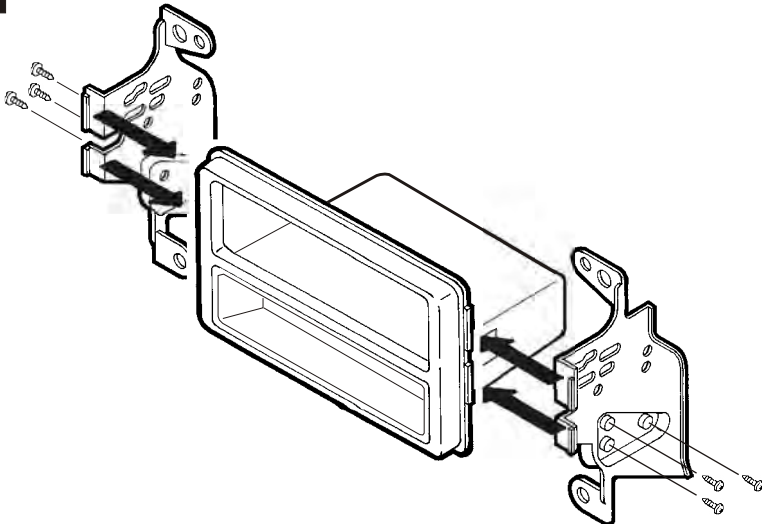

Attach the Mounting Brackets to the sides of the Radio Housing by inserting the slotted Bracket tabs into the slotted Housing tabs. (Be sure the mounting bosses on the Brackets align with the mounting bosses on the Pocket ). Mount the Brackets to the Pocket with (6) #6 x 1/4" Phillips Flat-Head Screws.

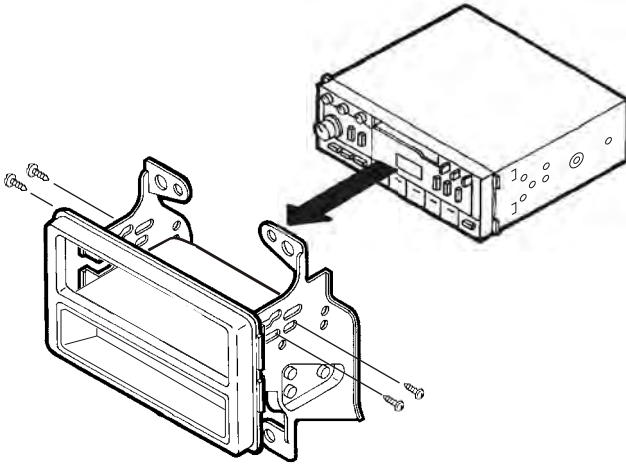
**5**

Align the holes in the Mounting Brackets with the holes in the ISO-DIN head unit and mount the Brackets to the head unit with the screws included with the unit.

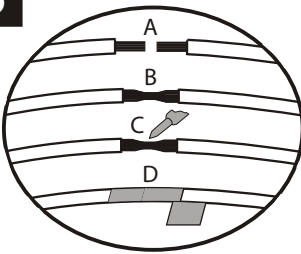
**6**

- A) Strip wire ends back 1/2"
- B) Twist ends together
- C) Solder
- D) Tape

Locate the factory wiring harness in the dash. Metra recommends using the proper mating adaptor and making connections as shown. (Isolate and individually tape off the ends of any unused wires to prevent electrical short circuit).

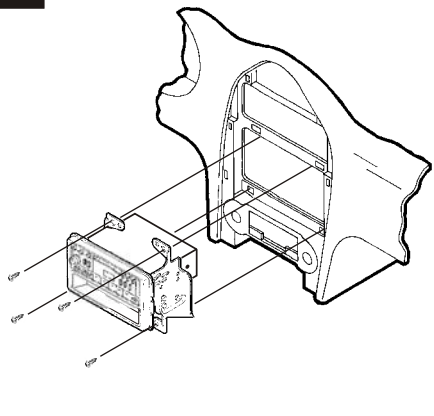
**7**

Re-connect the battery terminal and test the unit for proper operation. Mount the head unit/kit assembly to the sub-dash with (4) screws previously removed in step #1.