

KIT FEATURES

- ▶ Shaft and DIN unit provisions
- ▶ Various mounting depth alternatives



99-9000 AW-104UD DW-9000 INSTALLATION INSTRUCTIONS

KIT COMPONENTS

Underdash Housing

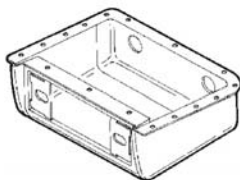

(8) Phillips

Screws

APPLICATIONS

MOUNTS AN AFTERMARKET 2-SHAFT OR DIN RECEIVER, COMPACT DISC PLAYER OR CB RADIO TO AN UNDERDASH LOCATION



TOOLS REQUIRED



Phillips screwdriver



Cutting tool



Adjustable wrench

☎ 1-800-221-0932 💻 www.metraonline.com

© COPYRIGHT 2001 METRA ELECTRONICS CORPORATION

rev. 230701

ALL VEHICLES

1

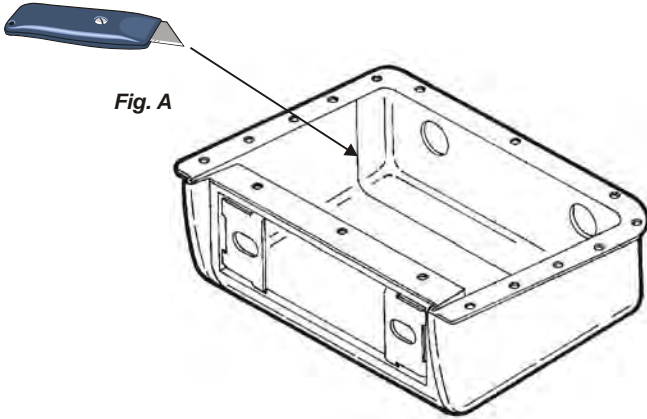

Disconnect the negative battery terminal to prevent an accidental short circuit. If an "open back" installation is desired (for additional depth), cut the **Underdash Housing** along the scored line and remove the rear portion of the Housing. (see Fig. A)

2

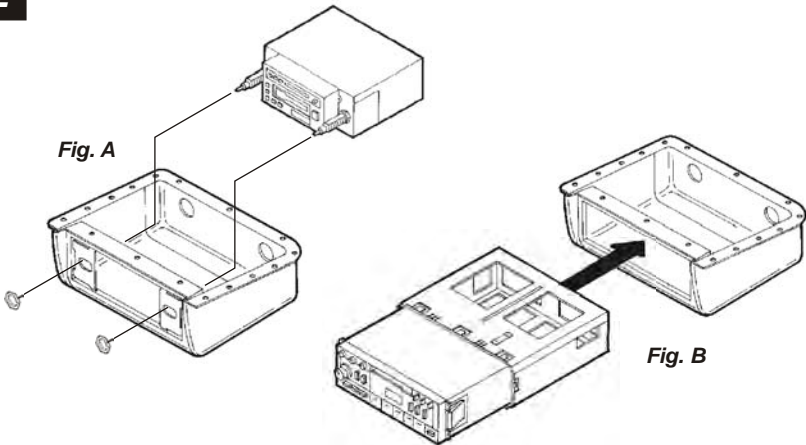

2-SHAFT HEAD UNITS: Slide the aftermarket head unit into the **Underdash Housing** and secure with shaft nuts. (see Fig. A)

DIN HEAD UNITS: Cut and remove the shaft supports from the **Underdash Housing**. Slide the DIN cage into the kit and secure by bending the metal locking tabs down. Slide the aftermarket head unit into the cage until secure. (see Fig. B)

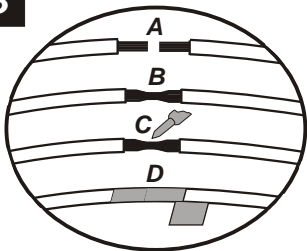
3

- A) Strip wire ends back ½"
- B) Twist ends together
- C) Solder
- D) Tape

Locate the factory wiring harness in the dash. Metra recommends using the proper mating adaptor and making connections as shown. (Isolate and individually tape off the ends of any unused wires to prevent electrical short circuit).

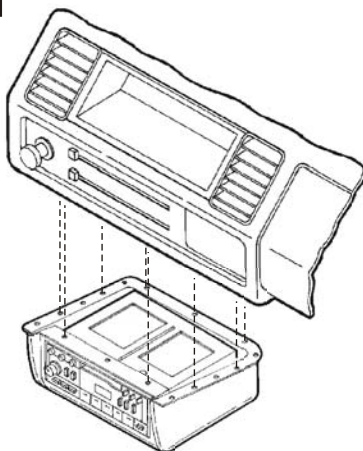
4

Place the head unit/kit assembly under the dash until the desired mounting location has been established. Mark the screw holes onto the dash.

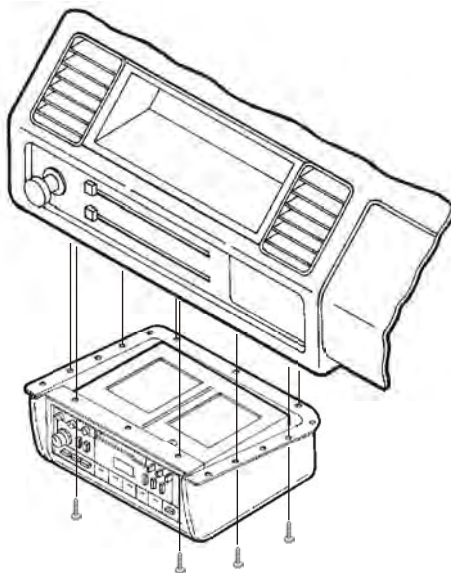
5

Re-connect the battery terminal and test the unit for proper operation. Mount the head unit/kit assembly to the pre-marked holes on the dash with (8) Phillips screws supplied. (If the back of the **Underdash Housing** was removed in step #1, fewer screws will be used).