

KIT FEATURES

- ▶ DIN head unit provisions



99-9300

INSTALLATION INSTRUCTIONS

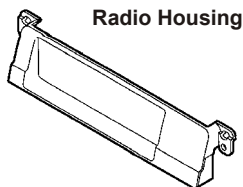
KIT COMPONENTS**APPLICATIONS****CAR****PAGE****BMW**

318 (All) 1999-2005.....	1-2
323 (All) 1997-2005.....	1-2
325 (All) 2001-2005.....	1-2
328 (All) 1997-2005.....	1-2
330 (All) 2001-2005.....	1-2

**TOOLS REQUIRED**

Phillips screwdriver



1-800-221-0932

www.metraonline.com

© COPYRIGHT 2001-07 METRA ELECTRONICS CORPORATION

rev. 06-18-07

ALL VEHICLES

1

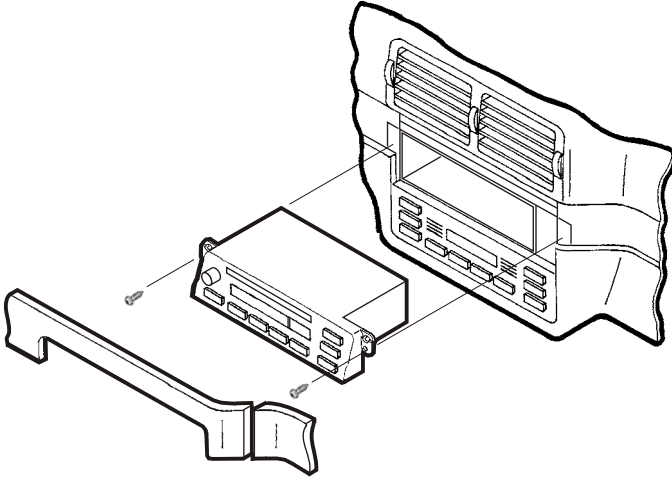

Disconnect the negative battery terminal to prevent an accidental short circuit. Gently unclip the wood-grained trim piece located above the glove box and remove. Gently unclip the wood-grained trim piece located above the radio opening and remove. Remove (2) Phillips screws securing the factory head unit and disconnect the wiring.

2

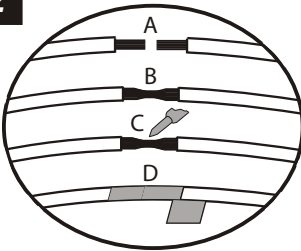

- A) Strip wire ends back 1/2"
- B) Twist ends together
- C) Solder
- D) Tape

Locate the factory wiring harness in the dash. Metra recommends using the proper mating adaptor and making connections as shown. (Isolate and individually tape off the ends of any unused wires to prevent electrical short circuit).

3

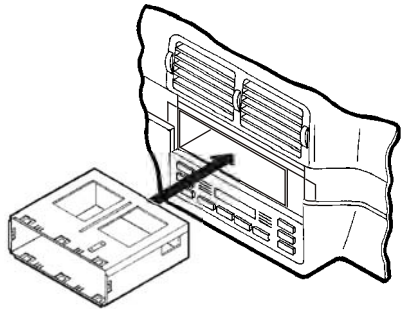

Slide the DIN cage into the dash cavity RESTING the cage on the RIGHT edge of the radio opening. (It is NOT necessary to secure the cage to the radio opening).

4

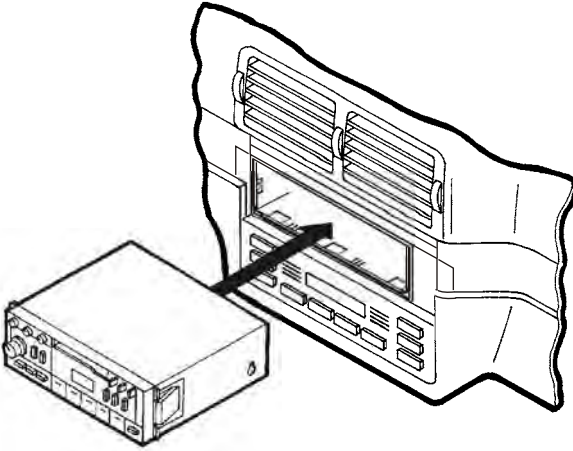

Slide the aftermarket head unit into the DIN cage until secure.

5

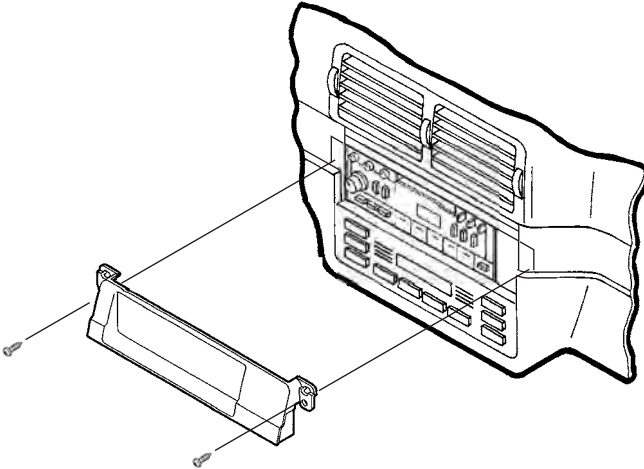

Re-connect the battery terminal and test the unit for proper operation. Mount the Radio Housing to the sub-dash with (2) screws previously removed in step #1.