



## INSTALLATION INSTRUCTIONS FOR PART 99-9401

### **APPLICATIONS** **2004-2006 Land Rover Freelander**

# 99-9401

#### **KIT FEATURES**

- DIN Head Unit Provision With Removable Pocket



#### **KIT COMPONENTS**

- A) Radio Housing    B) Pocket

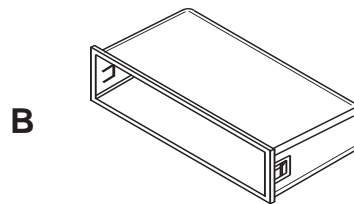
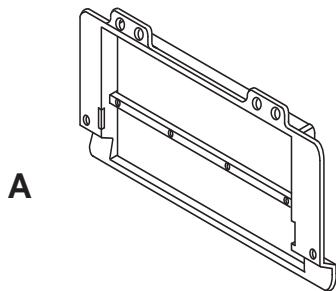

#### **TOOLS REQUIRED:**

- Socket Wrench • Phillips Screwdriver • Small Flat Blade Screwdriver

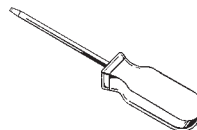
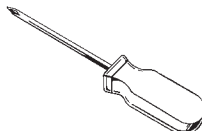
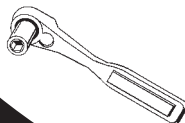

1-800-221-0932



[www.metraonline.com](http://www.metraonline.com)

© COPYRIGHT 2004-2007 METRA ELECTRONICS CORPORATION



# **TABLE OF CONTENTS**

---

*Dash Disassembly* .....1,2

*Kit Assembly* ..... 3

*Final Assembly* ..... 4

## 2004-2006 LAND ROVER FREELANDER

- 1 Disconnect the negative battery terminal to prevent an accidental short circuit.
- 2 Put gear shifter into neutral position then remove shift knob. (Figure A)
- 3 Unclip and remove gear shifter trim panel. (Figure B)
- 4 Unclip and remove rear ashtray panel from back of center console. (Figure C)
- 5 Open center console lid and remove cubby box. (Figure D)

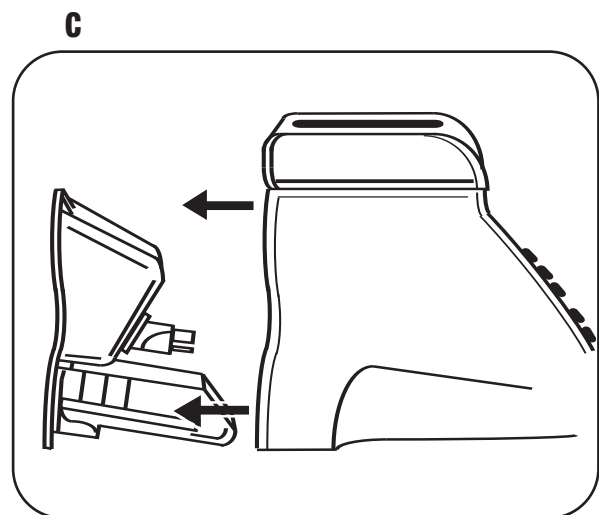
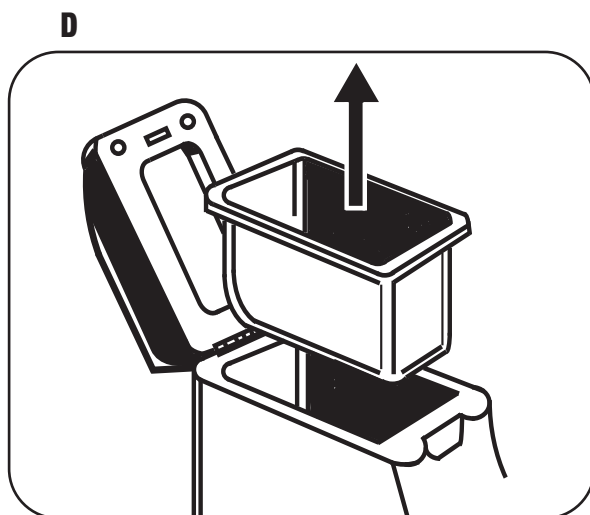
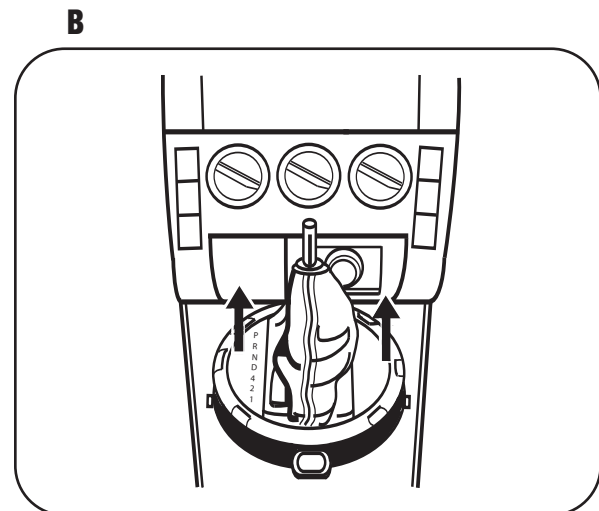
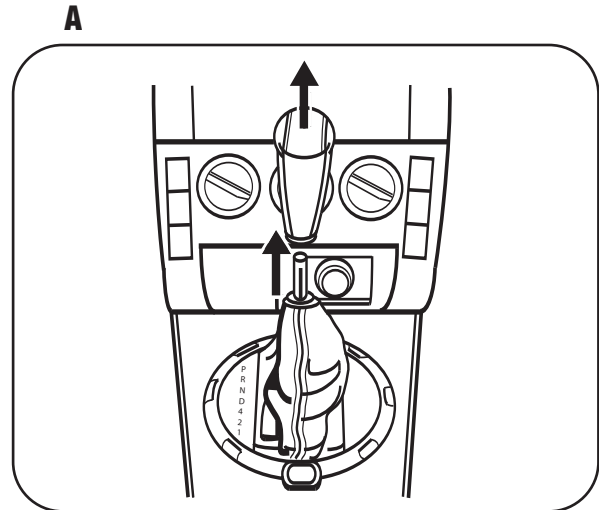

**2004-2006 LAND ROVER FREELANDER**

**6** Remove the (2) screws securing the rear of the center console. (Figure E)

**7** Remove the screw cover in front of the window switches then remove the (2) screws exposed underneath. (Figure F)

**8** Unclip and remove the upper console finisher panel between the a/c vents and radio.. (Figure G)

**9** Remove the (4) screws securing the center console. (Figure H)

Remove the (2) screws securing the radio.

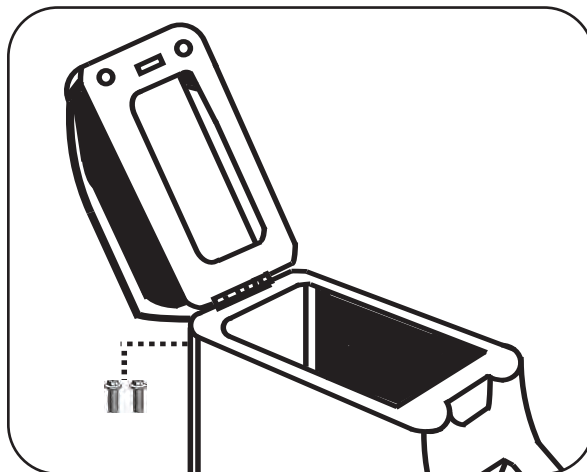
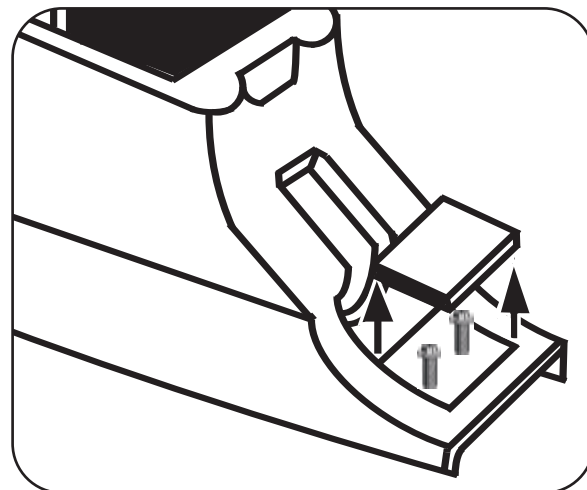
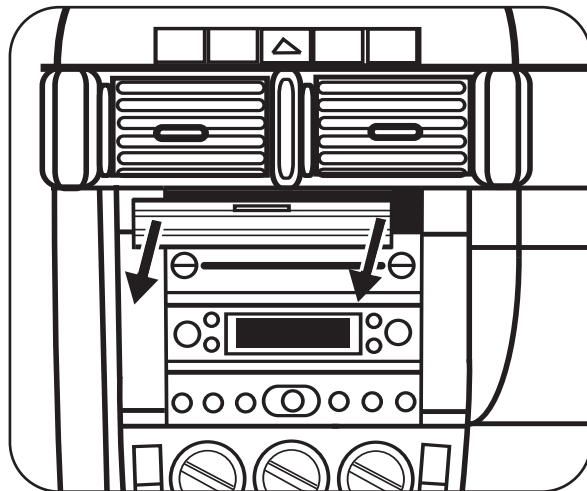
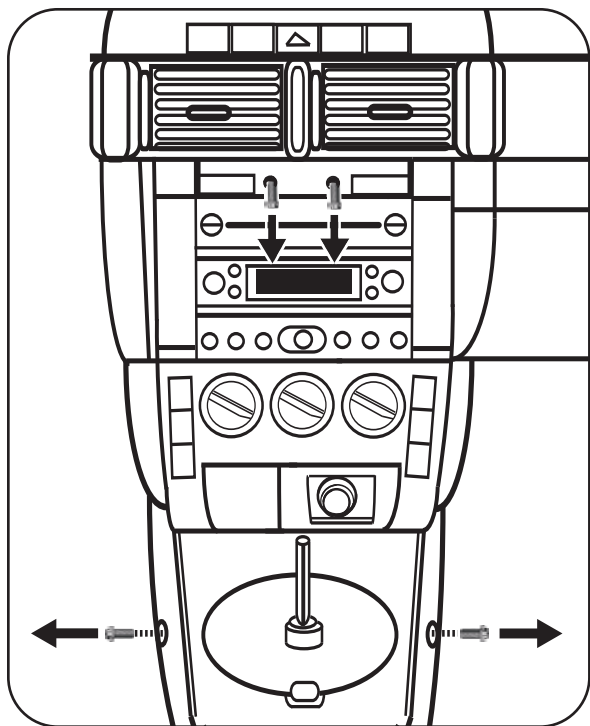
**E**

**F**

**G**

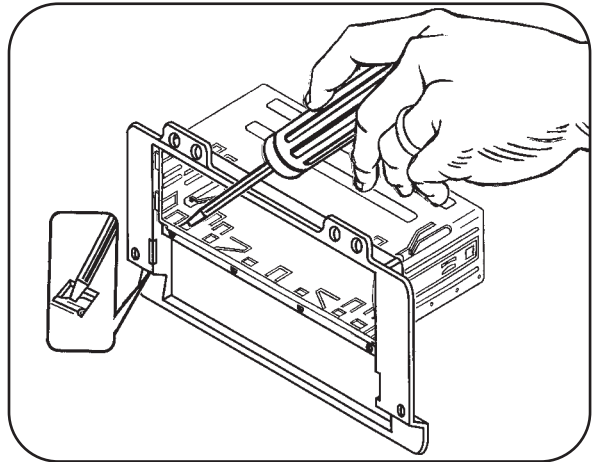
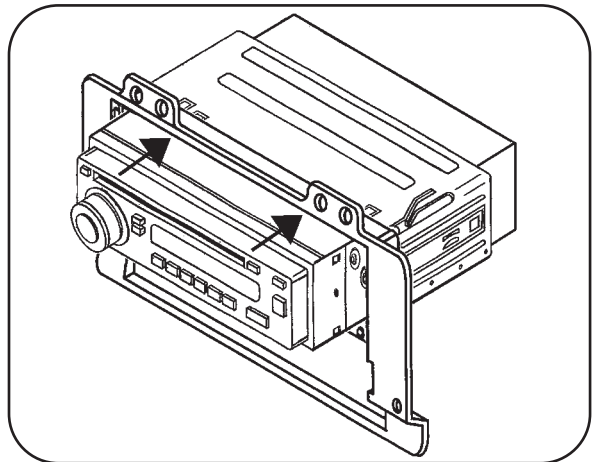
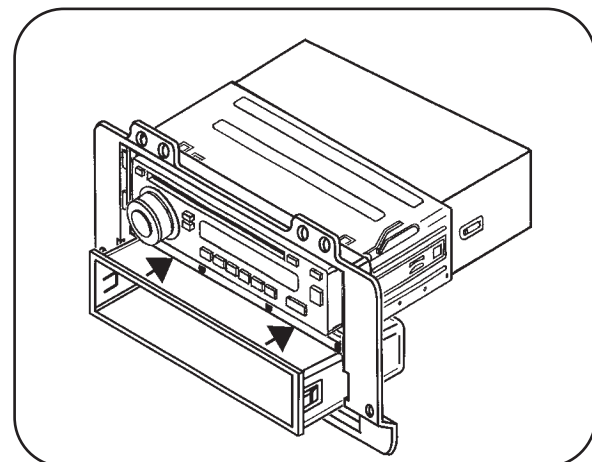
**H**

## **2004-2006 LAND ROVER FREELANDER** **DIN HEAD UNIT PROVISION**

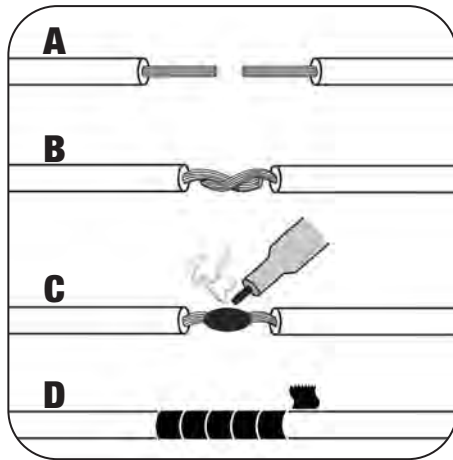
- 1** Slide the DIN cage into the Radio Housing and secure by bending the metal locking tabs down. (Figure A)
- 2** Slide the aftermarket head unit into the DIN cage until secure. (Figure B)
- 3** Slide the included pocket into the Radio Housing until secure. (Figure C)
- 4** Install kit assembly into dash.

**A****B****C**

## FINAL ASSEMBLY



- A) Strip wire ends back 1/2"**
- B) Twist ends together**
- C) Solder**
- D) Tape**

- 1** Locate the factory wiring harness in the dash. Metra recommends using the proper mating adapter and making connections as shown. (Isolate and individually tape off the ends of any unused wires to prevent electrical short circuit.)
- 2** Re-connect the negative battery terminal and test the unit for proper operation.
- 3** Reassemble radio and dash assemblies in reverse order of disassembly.

### FINAL WIRING CONNECTIONS

Make wiring connections using the EIA color code chart shown below and the instructions included with the head unit. Metra recommends making connections as shown below; Strip, Splice, Solder, Tape. Isolate and individually tape off ends of any unused wires to prevent electrical short circuit.

### METRA / EIA WIRING CODE

12V Ignition / Acc . . . Red	Dimmer . . . . . Orange / White
12V Batt / Memory . . Yellow	Right Front (+) . . . . White
Ground . . . . . Black*	Left Front (-) . . . . . White / Black
Power Antenna . . . . . Blue	Right Rear (+) . . . . . Violet
Amp Turn-On . . . . . Blue / White	Right Rear (-) . . . . . Violet / Black
Amp Ground . . . . . Black / White	Left Rear (+) . . . . . Green
Illumination . . . . . Orange	Left Rear (-) . . . . . Green / Black

**\*NOTE:** When Black a wire is not present, ground radio to vehicle chassis.  
All colors may not be present on all leads due to manufacturer's specifications.



# 99-9401 INSTRUCTIONS



1-800-221-0932



[www.metraonline.com](http://www.metraonline.com)

REV. 06/19/07

© COPYRIGHT 2004 METRA ELECTRONICS CORPORATION

INST99-9401