



GM ONSTAR CLASS II DATA BUS INTERFACE

GMOS-01

Installation Instructions

The **GMOS-01** is designed to be used in vehicles listed below to retain **Onstar** and the warning chimes that are lost when the OEM radio is removed, and also provide a 12 volt accessory output for proper aftermarket radio operation. The **GMOS-01** now provides a Mute, Parking Brake, VSS or Speed Sense, and Reverse outputs to make installing an aftermarket navigational radio simpler and less time consuming.

NOTE: This interface will also work in vehicles listed inside that are not equipped with Onstar)

APPLICATIONS

See inside for application list.

* READ IMPORTANT WARNING BEFORE ATTEMPTING ANY INSTALLATION

* IMPORTANT WARNING

THIS PRODUCT INCLUDES INSTRUCTIONS FOR INSTALLATION WHICH MUST BE CAREFULLY FOLLOWED. THE INSTRUCTIONS ARE WORDED IN SUCH A MANNER TO ASSUME THAT THE INSTALLER IS CAPABLE OF COMPLETING THESE TYPE OF ELECTRONIC INSTALLATIONS. IF YOU ARE UNCLEAR AS TO WHAT YOU ARE INSTRUCTED TO DO OR BELIEVE THAT YOU DO NOT UNDERSTAND THE INSTRUCTIONS SO AS TO PROPERLY AND SAFELY COMPLETE THE INSTALLATION YOU SHOULD CONSULT A TECHNICIAN WHO DOES HAVE THIS KNOWLEDGE AND UNDERSTANDING.

FAILURE TO FOLLOW THESE INSTRUCTIONS CAREFULLY AND TO INSTALL THE INTERFACE AS DESCRIBED COULD CAUSE HARM TO THE VEHICLE OR TO SAFETY SYSTEMS ON THE VEHICLE. INTERFERENCE WITH CERTAIN SAFETY SYSTEMS COULD CAUSE HARM TO PERSONS AS WELL.

IF YOU HAVE ANY QUESTIONS IN THIS REGARD PLEASE CALL THE HELP LINE OR THE METRA AT: 1-800-221-0932 FOR ASSISTANCE.



1-800-221-0932



www.metraonline.com



GMOS-01 APPLICATIONS

BUICK

Century	2004-2005
LaCrosse/ Allure	2005-2008
Rainier	2004-2007
Rendezvous	2002-2007
Terraza	2005-2008

CADILLAC

Escalade	2003- 2006
----------	------------

CHEVROLET

Avananche	2003-2006
Cavalier	2001-2005
Cavalier	2000
Colorado	2004-2008
Express	2003-2007
Impala	2002-2005
Impala	2000-2001
Malibu	2001-2003
Malibu Classic	2004
Monte Carlo	2002-2005
Monte Carlo	2000-2001
Silverado Classic	2007
Silverado	2003-2006
SSR	2003-2006
Suburban	2003-2006
Tahoe	2003-2006
Trailblazer	2002-2008
Uplander	2005-2008
Venture	2000-2005

GMC

Canyon	2004-2008
Envoy	2002-2008
Savana	2003-2007
Sierra Classic	2007
Sierra	2003-2006
Yukon / Yukon XL	2003-2006

HUMMER

H2	2003- 2007
H3	2006-2008

ISUZU

Ascender	2003-2000
I series pickup	2006-2008

OLDSMOBILE

Alero	2001-2004
Bravada	2002-2004
Intrigue	2002
Silhouette	2000-2004

PONTIAC

Aztec	2001-2005
Grand Am	2001-2005
Grand Prix	2004-2008
Montana SV6 (Canada)	2006-2007
Montana	2000-2005
Sunfire	2000-2005

SAAB

9-7x	2005-2007
------	-----------

SATURN

Relay	2005-2007
-------	-----------



INTERFACE COMPONENT

- GMOS-01 Data Interface
- 14 pin harness with stripped leads
- 12 pin harness to 12 and 24 pin GM harness with stripped leads

TOOLS REQUIRED FOR INSTALLATION

- Cutting Tool
- Tape
- Crimping Tool
- Connectors (ie: butt-connectors, bell caps, etc.)

WIRING UP THE GMOS-01

*** Important:** Before beginning any of the following, disconnect the negative battery terminal to prevent accidental short circuit.

****Note:** The ignition power source of most factory GM radios keep the radio on until one of the doors is opened. This is called the R.A.P. (retained accessory power). The GMOS-01 is designed to retain this feature.

FOR AFTERMARKET RADIO ONLY:

CONNECTIONS TO BE MADE ON THE 14 PIN HARNESS:

1. Connect the **red** wire to the ignition/accessory wire of the aftermarket radio.
2. Connect the **orange/white** wire to the illumination wire of the aftermarket radio. If the aftermarket radio has no illumination wire just tape off the **orange** wire.
3. Connect the **blue/white** wire to the amp turn on wire of the aftermarket radio and to the **blue/white** wire in the 24 pin harness.
4. Connect the **white** wire to the left front positive speaker output of the aftermarket radio.
5. Connect the **white/black** wire to the left front negative speaker output of the aftermarket radio.
6. Connect the **gray** wire to the right front positive speaker output of the aftermarket radio.
7. Connect the **gray/black** wire to the right front negative speaker output of the aftermarket radio.
8. Connect the **brown** wire to the mute wire of the aftermarket radio. If the after market radio does not have a Mute wire, tape up the **brown** wire.

The following wires on the 14 pin harness are for the aftermarket radios that have navigation built in:

1. Connect the **green** wire to the parking brake wire of the aftermarket navigation radio.
2. Connect the **blue/pink** wire to the VSS or speed sense wire of the aftermarket navigation radio.
3. Connect the **green/purple** wire to the reverse wire of the aftermarket navigation radio.

When completed, plug the 14 pin harness into the GMOS-01.

CONNECTIONS TO BE MADE ON THE 24 PIN GM HARNESS:

1. Connect the **yellow** wire to the radio's 12 volt battery or memory wire.
2. Connect the **black** wire to the radio's ground wire.
3. Connect the **blue/white** wire to the amp turn on wire of the aftermarket radio and to the **blue/white** wire of the 4 pin harness.
4. Connect the **green** wire to the radio's left rear positive speaker output.
5. Connect the the **green/black** wire to the radio's left rear negative speaker output.
6. Connect the **purple** wire to the radio's right rear positive speaker output.
7. Connect the **purple/black** wire to the radio's right rear negative speaker out put.
8. The **Orange** and **Orange/White** wires are not used. Please tape up wires to avoid a short circuit output.

CONNECTIONS TO BE MADE ON THE 12 PIN HARNESS:

1. The **brown** wire is for the Onstar volume adjustment. This will be discussed in the Onstar Level Adjustment section of this instruction.

When completed, plug the 12 pin harness into the GMOS-01.

FOR AFTERMARKET RADIO AND AMPLIFIER

[See wiring diagram on page 6]

CONNECTIONS TO BE MADE ON THE 14 PIN HARNESS:

1. Connect the **red** wire to the ignition/accessory wire of the aftermarket radio.
2. Connect the **Orange/white** wire to the illumination wire of the aftermarket radio. If the aftermarket radio has no illumination wire just tape off the **orange** wire.
3. Connect the **blue/white** wire to the amp turn on wire of the aftermarket radio and to the **blue/white** wire in the 24 pin harness.
4. **White** NOT USED
5. **White/black** NOT USED
6. **Gray** NOT USED
7. **Gray/black** NOT USED
8. Connect the **Brown** wire to the mute wire of the aftermarket radio. If the after market radio does not have a Mute wire, tape up the **Brown** wire.

The following wires on the 14 pin harness are for the aftermarket radios that have navigation built in:

1. Connect the **Green** wire to the parking brake wire of the aftermarket navigation radio.



Continued:

The following wires on the 14 pin harness are for the aftermarket radios that have navigation built in:

2. Connect the **Blue/Pink** wire to the VSS or speed sense wire of the aftermarket navigation radio.
3. Connect the **Green/Purple** wire to the reverse wire of the aftermarket navigation radio.

When completed, plug the 14 pin harness into the GMOS-01.

CONNECTIONS TO BE MADE ON THE 24 PIN GM HARNESS:

1. Connect the **yellow** wire to the radio's 12 volt battery or memory wire.
2. Connect the **black** wire to the radio's ground wire.
3. Connect the **blue/white** wire to the amp turn on wire of the aftermarket radio and to the **blue/white** wire of the 14 pin harness.
4. Connect the **green** wire to the amplifier's left rear positive speaker output.
5. Connect the the **green/black** wire to the amplifier's left rear negative speaker output.
6. Connect the **purple** wire to the amplifier's right rear positive speaker output.
7. Connect the **purple/black** wire to the amplifier's right rear negative speaker output.
8. The **Orange** and **Orange/White** wires are not used. Please tape up wires to avoid a short circuit output.
9. Cut the **white** wire about half way between the two plugs. Connect the **white** wire from the 24 pin plug to amplifier's left front positive speaker output wire. Connect the **white** wire from the 12 pin plug to the positive speaker wire of the Metra SP-2003 or equivalent.
10. Cut the **white/black** wire about half way between the two plugs. Connect the **white/black** wire from the 24 pin plug to amplifier's left front negative speaker output wire. Connect the **white/black** wire from the 12 pin plug to the negative speaker wire of the Metra SP-2003 or equivalent.
11. Cut the **gray** wire about half way between the two plugs. Connect the **gray** wire from the 24 pin plug to amplifier's right front positive speaker output wire. Connect the **gray** wire from the 12 pin plug to the positive speakerwire of the Metra SP-2003 or equivalent.
12. Cut the **gray/black** wire about half way between the two plugs. Connect the **gray/black** wire from the 24 pin plug to amplifier's right front negative speaker output wire. Connect the **gray/black** wire from the 12 pin plug to the negative speaker wire of the Metra SP-2003 or equivalent.

Note: If only one SP-2003 is used tape up the gray wires that would normally connect to the second SP-2003 to avoid a short circuit.

CONNECTIONS TO BE MADE ON THE 12 PIN HARNESS:

1. The **brown** wire is for the **Onstar** volume adjustment. This will be discussed in the **Onstar** Level Adjustment section of this instruction.

When completed, plug the 12 pin harness into the GMOS-01.

INSTALLING THE GMOS-01

1. With all connections completed to the aftermarket radio, plug the GM24 and GM12 pin harnesses into the vehicles wiring harnesses.
2. Reconnect the negative battery terminal.
3. Cycle the key by turning the ignition on then back off, then on again to test the radio.

TESTING THE GMOS-01

1. Turn the ignition on if not already, and then turn the radio on to verify that the radio works. Check the balance and fader control of the radio for proper operation.
2. Push the **Onstar** button (if so equipped) to verify **Onstar** is working properly. The radio will shut off or mute, depending if the **brown** wire on the 14 pin harness is connected, and **Onstar** will be heard through the front speakers. Turn off **Onstar** and the radio will turn back on.

CHIME VOLUME ADJUSTMENT

To adjust the chime volume, use a small screwdriver to rotate the potentiometer clockwise to make the chime louder and counterclockwise to make it softer. The potentiometer is located on the side of the GMOS-01.

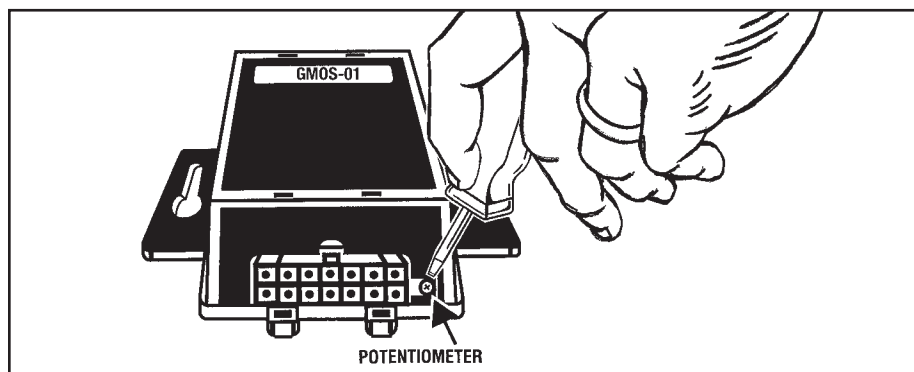

ONSTAR LEVEL ADJUSTMENT

To adjust the **Onstar** volume level find the **brown** wire on the 12 pin harness. Press the **blue** Onstar button, while the voice is talking tap the **Brown** wire to ground. Each time the **Brown** wire sees ground the volume level will change. There are 3 volume settings, low, medium, and high. The volume setting will be set until the **Brown** wire is tapped to ground again.

AFTERMARKET RADIO AND AMPLIFIER WIRING

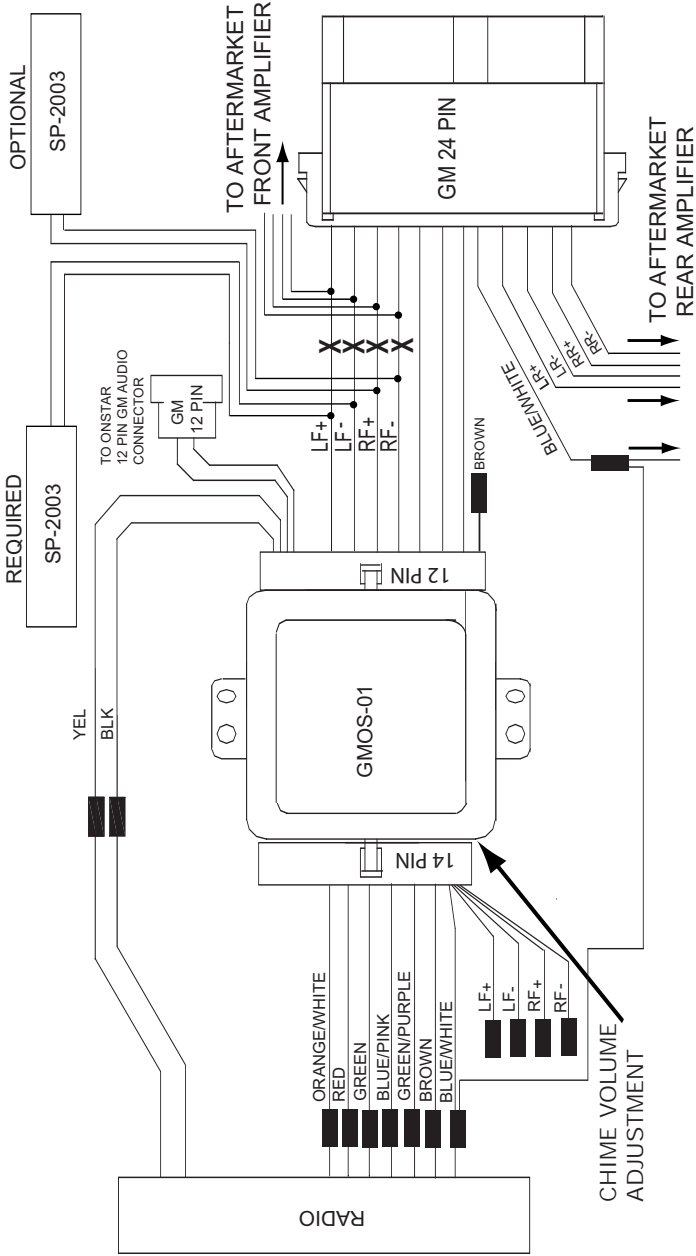

GMOS-01 INSTRUCTIONS

FINAL WIRING CONNECTIONS

Make wiring connections using the EIA color code chart shown below and the instructions included with the head unit. Metra recommends making connections as shown below; Strip, Splice, Solder, Tape. Isolate and individually tape off ends of any unused wires to prevent electrical short circuit.

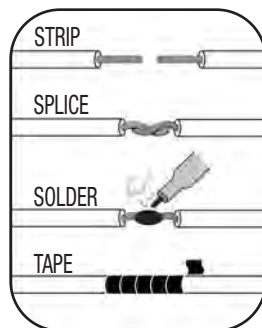

1-800-221-0932



www.metraonline.com

REV. 05/16/08 © COPYRIGHT 2004-2008 METRA ELECTRONICS CORPORATION INSTGMOS-01